

BeneLink Module

Operator's Manual



© Copyright 2016-2022 Shenzhen Mindray Bio-Medical Electronics Co., Ltd. All rights reserved.

Release time: December 2022

Revision: 14.0

WARNING

- **Federal Law (USA) restricts this device to sale by or on the order of a physician or other practitioner licensed by U.S. state law to use or order the use of this device.**
-
-

Intellectual Property Statement

SHENZHEN MINDRAY BIO-MEDICAL ELECTRONICS CO., LTD. (hereinafter called Mindray) owns the intellectual property rights to this Mindray product and this manual. This manual may refer to information protected by copyrights or patents and does not convey any license under the patent rights of Mindray, nor the rights of others.

Mindray intends to maintain the contents of this manual as confidential information. Disclosure of the information in this manual in any manner whatsoever without the written permission of Mindray is strictly forbidden.

Release, amendment, reproduction, distribution, rental, adaption and translation of this manual in any manner whatsoever without the written permission of Mindray is strictly forbidden.

mindray and **MINDRAY** are the registered trademarks or trademarks owned by Mindray in China and other countries. All other trademarks that appear in this manual are used only for editorial purposes without the intention of improperly using them. They are the property of their respective owners.

Responsibility on the Manufacturer Party

Contents of this manual are subject to changes without prior notice.

All information contained in this manual is believed to be correct. Mindray shall not be liable for errors contained herein nor for incidental or consequential damages in connection with the furnishing, performance, or use of this manual.

Mindray is responsible for the effects on safety, reliability and performance of this product, only if:

- all installation operations, expansions, changes, modifications and repairs of this product are conducted by Mindray authorized personnel;
- the electrical installation of the relevant room complies with the applicable national and local requirements;
- the product is used in accordance with the instructions for use.

WARNING

- **Only skilled/trained clinical professionals should operate this equipment.**
 - **It is important for the hospital or organization that employs this equipment to carry out a reasonable service/maintenance plan. Neglect of this may result in machine breakdown or personal injury.**
-

Warranty

THIS WARRANTY IS EXCLUSIVE AND IS IN LIEU OF ALL OTHER WARRANTIES, EXPRESSED OR IMPLIED, INCLUDING WARRANTIES OF MERCHANTABILITY OR FITNESS FOR ANY PARTICULAR PURPOSE.

Exemptions

Mindray's obligation or liability under this warranty does not include any transportation or other charges or liability for direct, indirect or consequential damages or delay resulting from the improper use or application of the product or the use of parts or accessories not approved by Mindray or repairs by people other than Mindray authorized personnel.

This warranty shall not extend to

- Malfunction or damage caused by improper use or man-made failure.
- Malfunction or damage caused by unstable or out-of-range power input.
- Malfunction or damage caused by force majeure such as fire and earthquake.
- Malfunction or damage caused by improper operation or repair by unqualified or unauthorized service people.
- Malfunction of the instrument or part whose serial number is not legible enough.
- Others not caused by instrument or part itself.

Company Contact

Manufacturer:	Shenzhen Mindray Bio-Medical Electronics Co., Ltd.
Address:	Mindray Building, Keji 12th Road South, Hi-tech industrial park, Nanshan, Shenzhen 518057, P.R.China
Website:	www.mindray.com
E-mail Address:	service@mindray.com
Tel:	+86 755 81888998
Fax:	+86 755 26582680
EC-Representative:	Shanghai International Holding Corp. GmbH(Europe)
Address:	Eiffestraße 80, 20537 Hamburg, Germany
Tel:	0049-40-2513175
Fax:	0049-40-255726

This page intentionally left blank.

Contents

1 Safety	1 - 1
1.1 Safety Information	1 - 1
1.2 Warnings	1 - 1
1.3 Cautions	1 - 2
1.4 Notes	1 - 2
2 Interfacing with External Devices	2 - 1
2.1 BeneLink Introduction	2 - 1
2.2 Physical Specifications	2 - 1
2.3 Data transmission	2 - 1
2.4 Supported Devices	2 - 2
2.4.1 Supported Anesthesia Machines	2 - 2
2.4.2 Supported Ventilators	2 - 3
2.4.3 Supported tcGas Monitoring Devices	2 - 5
2.4.4 Supported Infusion System (for BeneVision N Series Monitors)	2 - 5
2.4.5 Supported Other Devices	2 - 7
2.5 Connecting External Devices via DIAP Protocol (for BeneVision N Series Monitors)	2 - 7
2.5.1 Setting Parameter Output Properties	2 - 8
2.5.2 Setting the ID of the ID Adapter	2 - 8
2.5.3 Parsing the Monitor Data	2 - 8
2.6 Configuring the ID Adapter	2 - 8
2.7 Connecting External Devices	2 - 9
2.8 Connecting Bellavista 1000 Ventilator	2 - 10
2.9 Accessories	2 - 10
3 Integrating the Anesthesia Machine	3 - 1
3.1 Draeger Atlan A3X0 (For BeneVision N series Monitors)	3 - 1
3.1.1 Output Signals - Parameters	3 - 1
3.1.2 Output Signals - Alarms	3 - 4
3.1.3 Output Signals - Waveforms	3 - 8
3.2 Draeger Apollo	3 - 8
3.2.1 Output Signals - Parameters	3 - 8
3.2.2 Output Signals - Alarms	3 - 11
3.2.3 Output Signals - Waveforms (For BeneVision N series Monitors)	3 - 15

3.3 Draeger Fabius GS/Fabius GS Premium/Fabius plus/Fabius Tiro/Fabius plus XL	3 - 16
3.3.1 Output Signals - Parameters	3 - 16
3.3.2 Output Signals - Alarms	3 - 18
3.4 Draeger Perseus A500	3 - 19
3.4.1 Output Signals - Parameters	3 - 19
3.4.2 Output Signals - Alarms	3 - 22
3.4.3 Output Signals - Waveforms (For BeneVision N series Monitors)	3 - 26
3.5 Draeger Primus/Primus Infinity	3 - 26
3.5.1 Output Signals - Parameters	3 - 26
3.5.2 Output Signals - Alarms	3 - 29
3.5.3 Output Signals - Waveforms (For BeneVision N series Monitors)	3 - 33
3.6 Draeger Zeus/ZeusE	3 - 34
3.6.1 Output Signals - Parameters	3 - 34
3.6.2 Output Signals - Alarms	3 - 37
3.6.3 Output Signals - Waveforms (For BeneVision N series Monitors)	3 - 40
3.7 GE Aespire 7900&7100/ Aestiva 7900&7100	3 - 41
3.7.1 Output Signals - Parameters	3 - 41
3.7.2 Output Signals - Alarms	3 - 42
3.7.3 Output Signals - Waveforms (For BeneVision N series Monitors)	3 - 44
3.8 GE AespireView	3 - 45
3.8.1 Output Signals - Parameters	3 - 45
3.8.2 Output Signals - Alarms	3 - 46
3.8.3 Output Signals - Waveforms (For BeneVision N series Monitors)	3 - 48
3.8.4 Output Signals - Respiratory Loops (For BeneVision N series Monitors)	3 - 48
3.9 GE Aisys/Aisys CS2/Avance/Avance CS2/Carestation 650/620	3 - 49
3.9.1 Output Signals - Parameters	3 - 49
3.9.2 Output Signals - Alarms	3 - 53
3.9.3 Output Signals - Waveforms (For BeneVision N series Monitors)	3 - 59
3.9.4 Output Signals - Respiratory Loops (For BeneVision N series Monitors)	3 - 59
3.10 HuL Leon	3 - 60
3.10.1 Output Signals - Parameters	3 - 60
3.10.2 Output Signals - Alarms	3 - 62
3.11 HuL Leon Plus	3 - 67
3.11.1 Output Signals - Parameters	3 - 67
3.11.2 Output Signals - Alarms	3 - 69
3.12 MAQUET FLOW-i/c/e	3 - 74
3.12.1 Output Signals - Parameters	3 - 74

3.12.2 Output Signals - Alarms	3 - 77
3.12.3 Output Signals - Waveforms (For BeneVision N series Monitors)	3 - 79
3.12.4 Output Signals – Respiratory Loops (For BeneVision N series Monitors)	3 - 79
3.13 Mindray A9/A8/A7/A5/A4/A3/WATO EX-65/55/35/25/60/50/30/20/65 Pro/55 Pro	3 - 80
3.13.1 Output Signals - Parameters	3 - 80
3.13.2 Output Signals - Alarms	3 - 86
3.13.3 Output Signals - Waveforms (For BeneVision N series Monitors)	3 - 97
3.13.4 Output Signals – Respiratory Loops (For BeneVision N series Monitors)	3 - 97

4 Integrating the Ventilator 4 - 1

4.1 ACUTRONIC Fabian HFO (For BeneVision N series Monitors)	4 - 1
4.1.1 Output Signals - Parameters	4 - 1
4.1.2 Output Signals - Alarms	4 - 3
4.1.3 Output Signals - Waveforms (For BeneVision N series Monitors)	4 - 4
4.2 AirLiquide ALMS Monnal T75	4 - 5
4.2.1 Output Signals - Parameters	4 - 5
4.2.2 Output Signals - Alarms	4 - 6
4.3 Carefusion Avea(VOXP)	4 - 8
4.3.1 Output Signals - Parameters	4 - 8
4.3.2 Output Signals - Alarms	4 - 11
4.3.3 Output Signals - Waveforms (For BeneVision N series Monitors)	4 - 12
4.4 Carefusion Vela	4 - 12
4.4.1 Output Signals - Parameters	4 - 12
4.4.2 Output Signals - Alarms	4 - 14
4.5 Draeger Babylog 8000 plus/Babylog 8000	4 - 16
4.5.1 Output Signals - Parameters	4 - 16
4.5.2 Output Signals - Technical Alarms	4 - 17
4.6 Draeger Babylog VN500/VN800	4 - 17
4.6.1 Output Signals - Parameters	4 - 17
4.6.2 Output Signals - Alarms	4 - 20
4.6.3 Output Signals - Waveforms (For BeneVision N series Monitors)	4 - 22
4.7 Draeger Evita 2	4 - 23
4.7.1 Output Signals - Parameters	4 - 23
4.7.2 Output Signals - Alarms	4 - 25
4.8 Draeger Evita2 dura/Evita 4/Evita XL	4 - 27
4.8.1 Output Signals - Parameters	4 - 27
4.8.2 Output Signals - Alarms	4 - 29

4.8.3 Output Signals - Waveforms (For BeneVision N series Monitors)	4 - 32
4.9 Draeger Evita V300	4 - 32
4.9.1 Output Signals - Parameters	4 - 32
4.9.2 Output Signals - Alarms	4 - 35
4.9.3 Output Signals - Waveforms (For BeneVision N series Monitors)	4 - 38
4.10 Draeger Evita V600/Evita V800/Infinity V500	4 - 38
4.10.1 Output Signals - Parameters	4 - 38
4.10.2 Output Signals - Alarms	4 - 41
4.10.3 Output Signals - Waveforms (For BeneVision N series Monitors)	4 - 44
4.11 Draeger Savina 300	4 - 44
4.11.1 Output Signals - Parameters	4 - 44
4.11.2 Output Signals - Alarms	4 - 46
4.12 Draeger Oxylog 3000 plus	4 - 49
4.12.1 Output Signals - Parameters	4 - 49
4.12.2 Output Signals - Alarms	4 - 50
4.12.3 Output Signals - Waveforms (For BeneVision N series Monitors)	4 - 52
4.13 GE Carescape R860	4 - 52
4.13.1 Output Signals - Parameters	4 - 52
4.13.2 Output Signals - Alarms	4 - 55
4.13.3 Output Signals - Waveforms (For BeneVision N series Monitors)	4 - 60
4.13.4 Output Signals - Respiratory Loops (For BeneVision N series Monitors)	4 - 60
4.14 GE Engström Carestation	4 - 61
4.14.1 Output Signals - Parameters	4 - 61
4.14.2 Output Signals - Alarms	4 - 64
4.15 Hamilton C1/C1 NEO/C2/C3/C6/C6S/T1(Polling Protocol)	4 - 68
4.15.1 Output Signals - Parameters	4 - 68
4.15.2 Output Signals - Alarms	4 - 70
4.16 Hamilton C1/C6 (Block Protocol) (for BeneVision N series Monitors)	4 - 71
4.16.1 Output Signals - Parameters	4 - 71
4.16.2 Output Signals - Alarms	4 - 74
4.16.3 Output Signals - Waveforms	4 - 79
4.17 Hamilton G5 (Block Protocol)	4 - 79
4.17.1 Output Signals - Parameters	4 - 79
4.17.2 Output Signals - Alarms	4 - 82
4.17.3 Output Signals - Waveforms (For BeneVision N series Monitors)	4 - 87
4.18 Hamilton G5/S1 (Polling Protocol)	4 - 87
4.18.1 Output Signals - Parameters	4 - 87

4.18.2 Output Signals - Alarms	4 - 89
4.19 Hamilton Galileo (Polling Protocol)	4 - 90
4.19.1 Output Signals - Parameters	4 - 90
4.19.2 Output Signals - Alarms	4 - 92
4.20 Hamilton S1 (Block Protocol)	4 - 93
4.20.1 Output Signals - Parameters	4 - 93
4.20.2 Output Signals - Alarms	4 - 96
4.20.3 Output Signals - Waveforms (For BeneVision N series Monitors)	4 - 100
4.21 HuL Leoni Plus	4 - 101
4.21.1 Output Signals - Parameters	4 - 101
4.21.2 Output Signals - Alarms	4 - 102
4.22 Imtmedical Bellavista 1000 (For BeneVision N series Monitors)	4 - 106
4.22.1 Output Signals - Parameters	4 - 106
4.23 MAQUET SERVO-i/SERVO-s	4 - 109
4.23.1 Output Signals - Parameters	4 - 109
4.23.2 Output Signals - Alarms	4 - 112
4.23.3 Output Signals - Waveforms (For BeneVision N series Monitors)	4 - 114
4.23.4 Output Signals - Respiratory Loops (For BeneVision N series Monitors)	4 - 114
4.24 MAQUET SERVO-U/SERVO-N/SERVO-Air	4 - 115
4.24.1 Output Signals - Parameters	4 - 115
4.24.2 Output Signals - Alarms	4 - 118
4.24.3 Output Signals - Waveforms (For BeneVision N series Monitors)	4 - 119
4.24.4 Output Signals - Respiratory Loops (For BeneVision N series Monitors)	4 - 120
4.25 Mindray NB300/NB350/NB380 (For BeneVision N series Monitors)	4 - 120
4.25.1 Output Signals - Parameters	4 - 120
4.25.2 Output Signals - Alarms	4 - 121
4.25.3 Output Signals - Waveforms (For BeneVision N series Monitors)	4 - 124
4.26 Mindray SV60/SV60S/SV70/SV70S (For BeneVision N Series Monitors)	4 - 124
4.26.1 Output Signals - Parameters	4 - 125
4.26.2 Output Signals - Alarms	4 - 127
4.26.3 Output Signals - Waveforms	4 - 131
4.27 Mindray SV300/350/600/650/800/850	4 - 131
4.27.1 Output Signals - Parameters	4 - 131
4.27.2 Output Signals - Alarms	4 - 136
4.27.3 Output Signals - Waveforms (For BeneVision N series Monitors)	4 - 140
4.27.4 Output Signals - Respiratory Loops (For BeneVision N series Monitors)	4 - 141
4.28 Mindray SynoVent E3/E5	4 - 142

4.28.1 Output Signals - Parameters	4 - 142
4.28.2 Output Signals - Alarms	4 - 144
4.29 Newport E360	4 - 151
4.29.1 Output Signals - Parameters	4 - 151
4.29.2 Output Signals - Alarms	4 - 152
4.30 Philips Respironics V60 (SNDA Protocol)	4 - 155
4.30.1 Output Signals - Parameters	4 - 155
4.30.2 Output Signals - Alarms	4 - 155
4.31 Philips Respironics V60 (VRPT Protocol)	4 - 156
4.31.1 Output Signals - Parameters	4 - 156
4.31.2 Output Signals - Alarms	4 - 157
4.32 Puritan Bennett PB840/PB980 (SNDP Protocol)	4 - 158
4.32.1 Output Signals - Parameters	4 - 158
4.32.2 Output Signals - Alarms	4 - 160
4.33 Puritan Bennett PB840/PB980 (SNDA Protocol)	4 - 162
4.33.1 Output Signals - Parameters	4 - 162
4.33.2 Output Signals - Alarms	4 - 163
4.34 ResMed VSIII	4 - 164
4.34.1 Output Signals - Parameters	4 - 164
4.34.2 Output Signals - Alarms	4 - 165
4.35 Salvia Elisa 800/600/500/300	4 - 167
4.35.1 Output Signals - Parameters	4 - 167
4.35.2 Output Signals - Alarms	4 - 169
4.35.3 Output Signals - Waveforms (For BeneVision N series Monitors)	4 - 172
4.36 SLE600 (For BeneVision N series Monitors)	4 - 173
4.36.1 Output Signals - Parameters	4 - 173
4.36.2 Output Signals - Alarms	4 - 174

5 Integrating the tcGas Monitoring Device 5 - 1

5.1 RADIOMETER TCM40	5 - 1
5.1.1 Output Signals - Parameters	5 - 1
5.1.2 Output Signals - Alarms	5 - 2
5.2 RADIOMETER TCM4/TCM5/TCM CombIM	5 - 2
5.2.1 Output Signals - Parameters	5 - 2
5.2.2 Output Signals - Alarms	5 - 3
5.3 RADIOMETER TCM Tosca	5 - 3

5.3.1 Output Signals - Parameters	5 - 3
5.3.2 Output Signals - Alarms	5 - 4
5.4 SenTec Digital Monitor	5 - 4
5.4.1 Output Signals - Parameters	5 - 4
5.4.2 Output Signals - Alarms	5 - 5
6 Integrating Infusion System	6 - 1
6.1 B.Braun Infusion Space/Perfusor Space Pumps (For BeneVision N series Monitors)	6 - 1
6.1.1 Output Signals - Parameters	6 - 1
6.1.2 Output Signals - Technical Alarms	6 - 1
6.2 Carefusion Alaris GW/GH/PK/CC/CGW/CGH Infusion Management System (For BeneVision N Series Monitors)	6 - 2
6.2.1 Output Signals - Parameters	6 - 2
6.2.2 Output Signals - Technical Alarms	6 - 3
6.3 Fresenius Agilia Injectomat Series Infusion Pumps (For BeneVision N series Monitors)	6 - 3
6.3.1 Output Signals - Parameters	6 - 3
6.3.2 Output Signals - Technical Alarms	6 - 4
6.4 Fresenius Agilia Volumat Series Infusion Pumps (For BeneVision N series Monitors)	6 - 5
6.4.1 Output Signals - Parameters	6 - 5
6.4.2 Output Signals - Technical Alarms	6 - 5
6.5 Fresenius Base Intensive/Base Primea Infusion Management System (For BeneVision N Series Monitors)	6 - 6
6.5.1 Output Signals - Parameters	6 - 6
6.5.2 Output Signals - Technical Alarms	6 - 7
6.6 MedimaNet Server Infusing Monitoring and Archiving Network System (For BeneVision N series Monitors)	6 - 8
6.6.1 Output Signals - Parameters	6 - 8
6.7 Mindray BeneFusion DS5(VP5/SP5/SP5 TCI/SP5 DTCl) Pumps (For BeneVision N series Monitors)	6 - 8
6.7.1 Output Signals - Parameters	6 - 8
6.7.2 Output Signals - Technical Alarms	6 - 9
6.8 Mindray BeneFusion nDS/nVP/nSP	Pump (For BeneVision N series Monitors) 6 - 10
6.8.1 Output Signals - Parameters	6 - 10
6.8.2 Output Signals - Technical Alarms	6 - 12
7 Integrating Other Devices	7 - 1
7.1 Baxter Prismaflex/ PrisMax Hemodialysis (For BeneVision N Series Monitors)	7 - 1
7.1.1 Output Signals - Parameters	7 - 1

7.1.2 Output Signals - Technical Alarms (Baxter Prismaflex)	7 - 2
7.1.3 Output Signals - Technical Alarms (Baxter PrisMax)	7 - 10
7.2 Dräger babyleo TN500 Incubater (For BeneVision N Series Monitors only)	7 - 21
7.2.1 Output Signals - Parameters	7 - 21
7.2.2 Output Signals - Alarms	7 - 22
7.3 MAQUET Cardiosave hybrid IABP (For BeneVision N series Monitors)	7 - 23
7.3.1 Output Signals - Parameters	7 - 23
7.3.2 Output Signals - Alarms	7 - 24
7.4 MAQUET CS300/CS100 IABP (For BeneVision N series Monitors)	7 - 26
7.4.1 Output Signals - Parameters	7 - 26
7.4.2 Output Signals - Alarms	7 - 27
7.5 MAQUET PulsioFlex Cardiac Monitoring Device (For BeneVision N series Monitors)	7 - 28
7.5.1 Output Signals - Parameters	7 - 28
7.5.2 Output Signals - Alarms	7 - 30
7.6 Medasense PMD200 Pain Response Monitoring Device (For BeneVision N series Monitors)	7 - 31
7.6.1 Output Signals - Parameters	7 - 31
7.6.2 Output Signals - Technical Alarms	7 - 31
7.6.3 Output Signals - Waveforms (For BeneVision N series Monitors)	7 - 31
7.7 Narcotrend Compact M EEG Monitoring Devices (For BeneVision N series Monitors)	7 - 32
7.7.1 Output Signals - Parameters	7 - 32
7.7.2 Output Signals - Technical Alarms	7 - 33
7.7.3 Output Signals - Waveforms	7 - 34
7.8 NONIN X-100M Oximetry Monitor (For BeneVision N series Monitors)	7 - 34
7.8.1 Output Signals - Parameters	7 - 34
7.8.2 Output Signals - Alarms	7 - 36
7.9 Organon TOF-Watch SX NMT Monitoring Device	7 - 37
7.9.1 Output Signals - Parameters	7 - 37
7.9.2 Output Signals - Alarms	7 - 38
7.10 NIRO Monitor NIRO-200NX (For BeneVision N Series Monitors)	7 - 39
7.10.1 Output Signals - Parameters	7 - 39
8 BeneLink Function Test	8 - 1
8.1 Preparing the Tools	8 - 1
8.2 Checking the Function	8 - 1
8.3 Setting the Serial Ports	8 - 3

8.3.1 Setting the Serial Ports of the Anesthesia Machines	8 - 3
8.3.2 Setting the Serial Ports of the Ventilator	8 - 5
8.3.3 Setting the Serial Ports of the TcGas Monitoring Devices	8 - 9
8.3.4 Setting the Serial Ports of the Infusion Systems	8 - 10
8.3.5 Setting the Serial Ports of Other External Devices	8 - 12
8.4 Troubleshooting Device Integration Failures	8 - 14
8.5 Installation and Test Report	8 - 15
9 Alarm ID of External Devices	9 - 1
9.1 Alarm IDs of Anesthesia Machines	9 - 1
9.2 Alarm IDs of Ventilators	9 - 5
9.3 Alarm IDs of tcGas Monitoring Devices	9 - 9
9.4 Alarm IDs of NMT Monitoring Device	9 - 9
9.5 Alarm IDs of Infusion Systems (for BeneVision N series Monitors)	9 - 10
9.6 Alarm IDs of Other Devices	9 - 45
10 Capturing Fault Data	10 - 1
10.1 Tools Required for Data Capture	10 - 1
10.2 Data Capture Principle	10 - 1
10.3 Performing Data Capture	10 - 2

This page intentionally left blank.

1 Safety

1.1 Safety Information

WARNING

- Indicates a potential hazard or unsafe practice that, if not avoided, could result in death or serious injury.
-
-

CAUTION

- Indicates a potential hazard or unsafe practice that, if not avoided, could result in minor personal injury or product/property damage.
-
-

NOTE

- Provides application tips or other useful information to ensure that you get the most from your product.
-
-

1.2 Warnings

WARNING

- A patient monitor supports two BeneLink modules. The BeneView T Series monitor supports only one BeneLink module.
 - The BeneLink module receives parameter, alarm, and waveform data from external devices but will not modify this data. For example, the external device may display “----”, but send “0” to the patient monitor.
 - There can be differences between the alarm priorities displayed on your monitors and the priorities displayed on external devices interfaced through BeneLink. For details please see "Output signals – Alarms" section corresponding with each external device.
 - When the monitor connects external devices via the BeneLink module, the alarm delay for disconnection is less than 10 seconds.
-
-

1.3 Cautions

CAUTION

- **First installation and debugging should be executed by Mindray service personnel or authorized technician.**
 - **Software version of BeneLink modules using in the same department should be the same.**
 - **Check the compatibility of the external device and the ID adapter before connection. Not doing so may result in failure of the two devices to work together as desired.**
 - **Ports on the BeneLink module are not conventional network connectors. They are intended for connecting with the serial port of designated devices only. Do not connect them to public network interfaces.**
 - **The signal labels used on the patient monitor may be different from those given on the external device. For details please see “Output signals– Parameters” section corresponding with each external device. The alarms from external devices may be delayed before transmission to the patient monitor.**
-

1.4 Notes

NOTE

- **Devices of the same category cannot be connected to the BeneLink module simultaneously.**
 - **The alarm messages from external devices are derived from the open protocol of corresponding external device. For more information about these alarms, please see the operator’s manual of corresponding devices.**
 - **For the intended use and contraindication of the external devices, refer to their operator’s manuals.**
 - **When displayed in the monitor main screen, parameter labels of external devices are prefixed with the plug sign “+”. For example, if SpO2 is from an external device, its label is displayed as “+SpO2”, and its waveform label is displayed as “+Pleth”.**
 - **A plus sign “+” is added before each alarm message from external devices.**
-

2 Interfacing with External Devices

2.1 BeneLink Introduction

BeneLink module is intended for connecting external devices, such as ventilators and anesthesia machines, to the BeneVision N series monitor or BeneView T series monitors. It allows information (patient data, alarms, etc.) from external devices to be displayed, saved, recorded, or printed through the monitor. If the monitor is connected with the central monitoring system (CMS) or eGateway, information from external devices can also be transmitted to the CMS or eGateway.

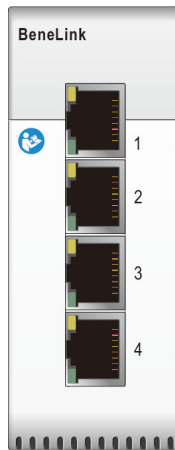

2.2 Physical Specifications

The physical specifications of the BeneLink module are as follows:

- Size: 136.5×40×102 mm
- Weight: 0.35 kg

2.3 Data transmission

The BeneLink module is connected with external devices via the serial ports (physical interfaces are RJ45 connectors). You can simultaneously connect up to four external devices via one BeneLink module. Parameters, respiratory waveforms, loops, alarm data from the external devices can be output.

2.4 Supported Devices

Please contact Mindray service personnel for the most recent information on the supported devices.

2.4.1 Supported Anesthesia Machines

Brand	Model	ID for ID adapter	Type of serial port adapting cable
Draeger	Atlan A3X0 (For BeneVision N series monitors)	4436BBCA	None needed
Draeger	Apollo	444FBBB1	Type C
Draeger	Fabius GS	4446BBBA	Type C
Draeger	Fabius GS Premium (for BeneVision N Series monitors)	4446BBBA	Type C
Draeger	Fabius plus/Fabius Tiro/Fabius plus XL	4446BBBA	Type C
Draeger	Perseus A500	4435BB CB	None needed
Draeger	Primus	4450BBB0	Type C
Draeger	Primus Infinity (For BeneVision N series monitors)	4450BBB0	Type C
Draeger	Zeus/ZeusIE	445ABBA6	None needed
GE	Aespire 7900/7100	4F37B0C9	Type D
GE	AespireView	4145bebb	Type D
GE	Aestiva 7900/7100	4F37B0C9	Type D
GE	Aisys	4F41B0BF	Type D
GE	Aisys CS2	4F41B0BF	Type D
GE	Avance/Avance CS2	4F41B0BF	Type D
GE	Carestation 620/650 (For BeneVision N series monitors)	4F41B0BF	Type D
HuL	Leon	484CB7B4	Type C
HuL	Leon Plus	4850B7B0	Type C
MAQUET	FLOW-i/c/e	4D46B2BA	Type B
Mindray	A9/A8/A4 (for BeneVision N series monitors)	4D52B2AE	None needed
Mindray	A7/A5/A3	4D52B2AE	None needed

Brand	Model	ID for ID adapter	Type of serial port adapting cable
Mindray	WATO EX-65/55/35/25/60/50/30/20/65 Pro/55 Pro	4D52B2AE	None needed

2.4.2 Supported Ventilators

Brand	Model	ID for ID adapter	Type of serial port adapting cable
ACUTRONIC	Fabian HFO (for BeneVision N Series monitors)	414FBEB1	Type C
AirLiquide	ALMS Monnal T75	4154BEAC	None needed
Carefusion	Avea(VOXP)	5645a9bb	Type E
Carefusion	Vela	564CA9B4	Type E
Draeger	Babylog8000/ Babylog8000 plus	4442BBBE	Type B
Draeger	Babylog VN500/Babylog VN800	4456BBAA	None needed
Draeger	Evita 2/Evita 2 dura/Evita 4/ Evita XL	4434BBCC	Type B
Draeger	Evita V300	4433BBBCD	None needed
Draeger	Evita V600 (for BeneVision N Series monitors)	4456BBAA	None needed
Draeger	Evita V800 (for BeneVision N Series monitors)	4456BBAA	None needed
Draeger	Infinity V500	4456BBAA	None needed
Draeger	Savina 300	4441BBBF	Type B
Draeger	Oxylog 3000 plus	4f58B0A8	Type C
GE	Carescape R860	4F52B0AE	Type B
GE	Engström Carestation	4F45B0BB	Type B
Hamilton	C1/C1 Neo/C2/C3/C6/C6s/T1 (Polling Protocol)	3270CD90	Type B
Hamilton	C1/C6 (Block Protocol) (for BeneVision N Series monitors)	3542CABE	Type B
Hamilton	G5 (Block Protocol)	3542CABE	Type B
Hamilton	G5/S1 (Polling Protocol)	3550CAB0	Type B

Brand	Model	ID for ID adapter	Type of serial port adapting cable
Hamilton	Galileo (Polling Protocol)	4750B8B0	Type B
Hamilton	S1 (Block Protocol)	5331ACCF	Type B
HuL	Leoni Plus	4849B7B7	Type C
Imtmedical	Bellavista 1000 (for BeneVision N Series monitors)	4256BDAA	Bellavista adapter. For more information, see 2.8 Connecting Bellavista 1000 Ventilator
MAQUET	SERVO-I/SERVO-s	4D53B2AD	Type B
MAQUET	SERVO-U/SERVO-N	4d55B2AB	Type B
MAQUET	SERVO Air	4d55B2AB	Type B
Mindray	NB300/NB350/NB380 (for BeneVision N Series monitors)	4D56B2AA	None needed
Mindray	SV 300/350/600/650/800/850	4D56B2AA	None needed
Mindray	SV60/SV60S/SV70/SV70S	4D56B2AA	None needed
Mindray	SynoVent E3/SynoVent E5	4D56B2AA	None needed
Newport	E360	4E50B1B0	Type B
Philips	Respironics V60	5636A9CA (SDNA) 5637A9C9 (VRPT)	25-pin (male) to 9-pin (female) null modem type cable (universal) + Type B
Puritan Bennett	PB840 (SNDF protocol)	5042AFBE	None needed
Puritan Bennett	PB840 (SNDA protocol)	5031AFCF	None needed
Puritan Bennett	PB980 (SNDF protocol)	5042AFBE	Type C
Puritan Bennett	PB980 (SNDA protocol)	5031AFCF	Type C
ResMed	VSIII	5653A9AD	Type C
Salvia	Elisa 800/600/500/300	5341ACBF	None needed
SLE	SLE6000 (for BeneVision N Series monitors)	534CACB4	Type C

2.4.3 Supported tcGas Monitoring Devices

Brand	Model	ID for ID adapter	Type of serial port adapting cable
RADIOMETE R	TCM40/TCM4	5443ABBD	Type C
RADIOMETE R	TCM Tosca/TCM CombiM	5443ABBD	Type C
RADIOMETE R	TCM5	5443ABBD	Type B
SenTec	SenTec Digital Monitor	5354ACAC	Type C

2.4.4 Supported Infusion System (for BeneVision N Series Monitors)

Brand	Model	ID for ID adapter	Type of serial port adapting cable
B.Braun	Infusomat Space(Single pump connection is not supported)	4250BDB0	Type F
B.Braun	Perfusor Space(Single pump connection is not supported)	4250BDB0	Type F
Carefusion	Alaris Pump GW/GH/PK/CC/CGW/CGH(Single pump connection is not supported)	414CBEB4	RJ45ToSerial Moduler Server
Fresenius	Agilia Injectomat (It supports both single pump and Link+ connections.)	4650b9b0	Type G
Fresenius	Agilia Injectomat MC (It supports both single pump and Link+ connections.)	4650b9b0	Type G
Fresenius	Agilia Injectomat TIVA (It supports both single pump and Link+ connections.)	4650b9b0	Type G

Brand	Model	ID for ID adapter	Type of serial port adapting cable
Fresenius	Agilia Volumat (It supports both single pump and Link+ connections.)	4650b9b0	Type G
Fresenius	Agilia Volumat MC (It supports both single pump and Link+ connections.)	4650b9b0	Type G
Fresenius	Agilia SP MC (It supports both single pump and Link+ connections.)	4650b9b0	G 型
Fresenius	Agilia VP MC (It supports both single pump and Link+ connections.)	4650b9b0	G 型
Fresenius	Link+ (It supports both Agilla pump and Link+ connections.)	4650b9b0	4-port metal: Type G 8-port metal + plastic: Type C
Fresenius	Orchestra Base Intensive/ Base Primea(Single pump connection is not supported)	6F72908E	Type B
Medima	MedimaNet Server(Single pump connection is not supported)	4D50B2B0	RJ45ToSerial Moduler Server
Mindray	BeneFusion DS5 (VP5/ SP5/SP5 TCI/SP5 DTCl) (Single pump connection is not supported)	534bacb5	Type H
Mindray	BeneFusion nDS/nVP/ nSP(It supports both single pump and Dock connections.)	5052AFAE	Type I

2.4.5 Supported Other Devices

Brand	Model	ID for ID adapter	Type of serial port adapting cable
Baxter/ Hemodialysis	Prismaflex / PrisMax(for BeneVision N series monitors)	5058AFA8	Type C
Dräger/Incubater	babyleo TN500 (for BeneVision N series monitors)	4454BBAC	None needed
MAQUET/cardiac monitoring device	PulsioFlex (for BeneVision N series monitors)	5055afab	USB to serial adapter (ATEN USB to Serial Adapter UC- 232A)
MAQUET/IABP	CardioSave hybrid (for BeneVision N series monitors)	4942B6BE	RJ45ToSerial Moduler Server
MAQUET/IABP	CS300,CS100 (for BeneVision N series monitors)	4941b6bf	Standard male to male 9-Pin serial adapter cable. Maximum size of the connector is 15 mm × 33 mm.
Medasense/Pain response monitoring device	PMD200 (for BeneVision N series monitors)	504DAFB3	None needed
Narcotrend/EEG monitoring device	Compact M (for BeneVision N series monitors)	4e43b1bd	None needed
NONIN	X-100M (for BeneVision N series monitors)	4E6FB191	None needed
Organon/ NMT monitoring device	TOF Watch SX®	5457ABA9	Type C
NIRO Monitor NIRO- 200NX	NIRO-200NX (for BeneVision N series monitors)	4e58b1a8	None needed

2.5 Connecting External Devices via DIAP Protocol (for BeneVision N Series Monitors)

The ID adapter can be configured to support the DIAP protocol. When the ID adapter is connected to the BeneLink module, the third party device can obtain the measurement numerics and alarm limit settings of the current patient through the DIAP protocol.

2.5.1 Setting Parameter Output Properties

You must configure the DIAP protocol to realize the communication between the monitor and the third party device. To do so, proceed as follows:

1. Select the **Main Menu** quick key → from the **System** column select **Maintenance** → input the required password → select **↵**.
2. Select the **Others** tab → **Parameter Output Setup**.
3. Set **Baud Rate**, **Parity Mode**, **Data Bits** or **Stop Bits** as desired.

2.5.2 Setting the ID of the ID Adapter

The ID of the virtual serial port is 6000a000. For the method of setting the ID, refer to **2.6 Configuring the ID Adapter**.

2.5.3 Parsing the Monitor Data

To parse the monitor data, refer to **DIAP Communication Protocol Service Manual (PN: 046-012201-00)**.

2.6 Configuring the ID Adapter

To configure the ID adapter to work with your external device, follow this procedure:

1. Select **Update ID module**:
 - ◆ For BeneVision N Series monitor, select the **Main Menu** quick key → from the **System** column select **Maintenance** → input the factory maintenance password → select **Ok** → select the **Factory Maintenance** tab → select the **Setup** tab → select **Update ID module**.
 - ◆ For BeneVision T series, select **Main Menu** → **Factory Maintenance>>** → input the factory maintenance password → **Update ID module**].
2. Set **Benelink Module Port** and **ID**.
 - ◆ The setting of **Benelink Module Port** shall be consistent with the port the RJ45 connecting cable is connected to.
 - ◆ You must connect the RJ45 connecting cable to the selected port when configuring the ID adapter. Otherwise, ID adapter configuration will fail.
 - ◆ Set **ID** to configure a new ID to the ID adapter. Refer to Column "ID for ID Adapter" in the tables of **2.4 Supported Devices** to obtain the ID information for each external device.

CAUTION

- **ID adapter setup should only be conducted by Mindray authorized personnel.**
-

2.7 Connecting External Devices

The external devices are connected with the BeneLink module through an ID adapter, which supports only its matching device. Please refer to the following procedure to connect an external device:

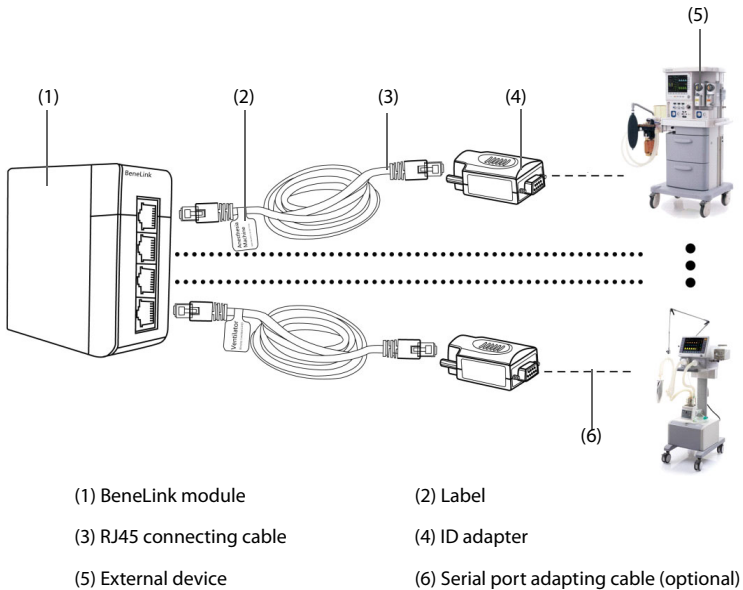

1. Make sure that BeneLink module contains the device drivers which match the devices you want to connect. If it doesn't, you could install driver to BeneLink by using PC upgrade program. After upgrade, stick a label on BeneLink module to indicate installed device drives.
2. Insert the BeneLink module into the SMR or module rack.
3. Connect the ID adapter that matches the external device to the BeneLink module with an RJ45 connecting cable.
4. Plug the ID adapter into the RS232 port on the external device. Some external devices may have ports incompatible with the ID adapter. In this case, a serial port adapting cable is required.
5. Adhere a device name label to the RJ45 connecting cable at the end close to the BeneLink module. When the BeneLink module is connected to several external devices, you can identify devices easily with these labels.
6. Switch on the external device.

After the external device is connected to the monitor, the indicators on both the ID adapter and the BeneLink module illuminate to show that the monitor is successfully communicating with the external device.

2.8 Connecting Bellavista 1000 Ventilator

Connect the Bellavista 1000 ventilator according to the figure below:

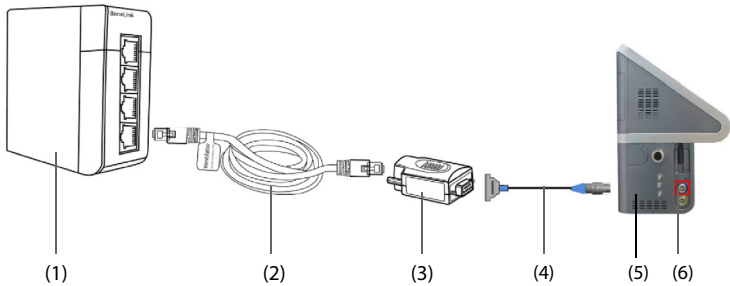

- (1) BeneLink module
(2) RJ45 connecting cable
(3) ID adapter
(4) Bellavista adapter for external devices
(5) Bellavista 1000 ventilator
(6) Blue connector for external devices

1. Insert the BeneLink module into the SMR or module rack.
2. Connect the ID adapter that matches the external device to the BeneLink module with an RJ45 connecting cable.
3. Use the Bellavista adapter to connect the ID adapter and the ventilator: connect the D-Sub connector to the ID adapter and the ODU connector to the blue connector on the right side of the Bellavista ventilator.
4. Adhere a device name label to the RJ45 connecting cable at the end close to the BeneLink module. When the BeneLink module is connected to several external devices, you can identify devices easily with these labels.

NOTE

- **Contact Bellavista for the Bellavista adapter for external devices.**

2.9 Accessories

PN	Description
115-007277-00	ID adapter
009-001767-00	Serial port adapting cable, Type A, male to female, cross-over
009-001768-00	Serial port adapting cable, Type B, male to male, straight-through

PN	Description
009-001769-00	Serial port adapting cable, Type C, male to male
009-002943-00	Serial port adapting cable, Type D, 9-pin to 15-pin
009-004613-00	Serial port adapting cable, Type E, 9-pin to RJ45 connector
009-008485-00	Serial port adapting cable, Type F, 9-pin
009-008624-00	Serial port adapting cable, Type G, 9-pin
009-009309-00	Serial port adapting cable, Type H
009-010321-00	Serial port adapting cable, Type I
009-009488-00	Serial port adapting cable, Type J
009-004286-00	Serial cable assembly
047-004857-00	ID adapter label
047-004859-00	Network line label
009-001770-00	RJ45 connecting cable

NOTE

- **RJ45ToSerial Moduler Server FBPORT2100 of HANGZHOU HUIITE TECHNOLOGY CO.,LTD. is recommended.**

This page intentionally left blank.

3 Integrating the Anesthesia Machine

3.1 Draeger Atlan A3X0 (For BeneVision N series Monitors)

3.1.1 Output Signals - Parameters

Monitor output: alarms from Draeger Atlan A3X0 anesthesia machine			
Labels	Units	Description	Trend, record, print
Monitoring Parameters			
ftotal	bpm	Total respiratory rate	Yes
fspn	bpm	Spontaneous respiratory rate	Yes
Raw	cmH2O/L/s,hPa/L/s,mbar/L/s	Airway resistance	Yes
VCO ₂	ml/min	CO ₂ production	No
HALLev	ml	Anesthetic agent consumption	No
ENFLev	ml		
ISOLev	ml		
DESLev	ml		
SEVLev	ml		
VO ₂	ml/min	Oxygen consumption	Yes
Pmean	cmH2O, hPa, mbar	Mean pressure	Yes
Pplat	cmH2O, hPa, mbar	Plateau pressure	Yes
PEEP	cmH2O, hPa, mbar	Positive end-expiratory pressure	Yes
Ppeak	cmH2O, hPa, mbar	Peak pressure	Yes
Insp. MAC	\	Inspired minimum alveolar concentration	No
Exp. MAC	\	Expired minimum alveolar concentration	No

Monitor output: alarms from Draeger Atlan A3X0 anesthesia machine			
Labels	Units	Description	Trend, record, print
FiN ₂ O	%	Inspired anesthetic agent	Yes
FiIso	%		
FiDes	%		
FiEnf	%		
FiSev	%		
FiHal	%		
EtN ₂ O	%	End-tidal anesthetic agent	Yes
EtEnf	%		
EtDes	%		
EtIso	%		
EtSev	%		
EtHal	%		
MVspn	L/min	Spontaneous breathed minute volume	Yes
MV	L/min	Minute volume	Yes
Apnea T _{insp}	sec	Apnea time	No
ΔO ₂	%,kPa,mmHg	Difference between inspiratory and expiratory O ₂	No
RRCO ₂	bpm	Respiratory rate of CO ₂	Yes
FiCO ₂	%,kPa,mmHg	Fraction of inspired carbon dioxide	Yes
EtCO ₂	%,kPa,mmHg	End-tidal carbon dioxide	Yes
N ₂ O Flow	L/min	N ₂ O flow	Yes
Air Flow	L/min	Air flow	Yes
O ₂ Flow	L/min	O ₂ flow	Yes
FiCO ₂ %	%	Fraction of inspired carbon dioxide	Yes
EtCO ₂ %	%	End-tidal carbon dioxide	Yes
FiAA	%	Inspired anesthetic agent	Yes

Monitor output: alarms from Draeger Atlan A3X0 anesthesia machine			
Labels	Units	Description	Trend, record, print
EtAA	%	End-tidal anesthetic agent	Yes
FiAA 2nd	%	2nd Insp. Agent	Yes
EtAA 2nd	%	2nd Exp. Agent	Yes
EtO2%	%	End-tidal O ₂	Yes
FiO2%	%	Fractional concentration of O ₂ in inspired gas	Yes
Compl	ml/cmH2O,ml/hPa,ml/mbar	Compliance	Yes
TVi	ml	Inspired tidal volume	Yes
TVe	ml	Expiratory tidal volume	Yes
ΔVT	ml	Delta tidal volume	No
Setting Parameters			
VTi	ml	Inspired tidal volume	No
f	bpm	Breath rate	No
Tinsp	sec	Time of inspiration	No
PS above PEEP	cmH2O, hPa, mbar	PS above PEEP	No
PEEP	cmH2O, hPa, mbar	Positive end-expiratory pressure	No
Pmax	cmH2O, hPa, mbar	Maximum airway pressure	No
F-Trig	L/min	Inspiratory trigger level (flow trigger)	No
TIP:TI	%	Percentage of inspiratory plateau time in inspiratory time	No
Tslope	sec	Time for the pressure to rise to target pressure	No
FG	ml/min	Fresh gas flow	No
Pinsp	cmH2O, hPa, mbar	Pressure control level of inspiration	No
TVi	ml	Inspired tidal volume	No
f	bpm	Breath rate	No
Tinsp	sec	Time of inspiration	No

Monitor output: alarms from Draeger Atlan A3X0 anesthesia machine			
Labels	Units	Description	Trend, record, print
PS above PEEP	cmH2O, hPa, mbar	PS above PEEP	No
PEEP	cmH2O, hPa, mbar	Positive end-expiratory pressure	No
Pmax	cmH2O, hPa, mbar	Maximum airway pressure	No
F-Trig	L/min	Inspiratory trigger level (flow trigger)	No
TIP:TI	%	Percentage of inspiratory plateau time in inspiratory time	No
Tslope	sec	Time for the pressure to rise to target pressure	No
FG	ml/min	Fresh gas flow	No
Pinsp	cmH2O, hPa, mbar	Pressure control level of inspiration	No

3.1.2 Output Signals - Alarms

Monitor output: alarms from Draeger Atlan A3X0 anesthesia machine		
Priority	Label	Label
Physiological alarms		
High	Apnea	APNEA or APNEA VOL
High	FiO2 Low	%O2 LOW
High	CO2 Apnea	APNEA CO2
High	Pressure Apnea	APNEA PRES
High	Paw High	PAW HIGH
High	Paw Low	PAW LOW / PAW NEGATIVE
High	CONT PRES	CONT PRES
High	AW-TEMP High	AW-TEMP HIGH
Medium	FiHal High	% HAL HIGH
Medium	FiEnf High	% ENF HIGH

Monitor output: alarms from Draeger Atlan A3X0 anesthesia machine		
Priority	Label	Label
Medium	Filso High	% ISO HIGH
Medium	MV Low	MIN VOL LOW
Medium	FiSev High	% SEV HIGH
Medium	FiDes High	% DES HIGH
Medium	EtCO ₂ Low	ET CO ₂ LOW
Medium	EtCO ₂ High	ET CO ₂ HIGH
Medium	FiHal Low	% HAL LOW
Medium	FiEnf Low	% ENF LOW
Medium	Filso Low	% ISO LOW
Medium	FiDes Low	% DES LOW
Medium	FiSev Low	% SEV LOW
Medium	FiO ₂ High	% O ₂ HIGH
Medium	FiCO ₂ High	INSP CO ₂ HI
Medium	MV High	MIN VOL HIGH
Medium	PEEP High	PEEP HIGH
Medium	MAC High	INSP MAC HI
Medium	MAC Low	MAC LOW?
Medium	FiN ₂ O High	% N ₂ O HIGH
Technical alarms		
High	O ₂ Supply Failure	O ₂ SUPPLY?
High	NO Fresh Gas	NO FRESHGAS
High	VENT DISC	VENT ASSEMBL

Monitor output: alarms from Draeger Atlan A3X0 anesthesia machine		
Priority	Label	Label
High	High Technical Alarm	If the monitor shows the alarm [High Technical alarms], the external device may have the following alarms: CO2 ERR VENT ERR MIXER INOP NT.TMP.HIGH AIR PRESS HI HI O2 SUPPLY SYSTEM FAULT BATTERY ERR N2O CYL.? NO_N2O NO OXYGEN NO AIR FG EXTERN?
Medium	FRESH GAS?	FRESH GAS?
Medium	CO2 Module Abnormal	CO2 LINE BLK
Medium	AG Module abnormal	If the monitor shows the alarm [AG Module abnormal], the external device may have the following alarms: IXED AGENT GAS MON ERR 2nd AGENT WATERTR.OLD?
Medium	Medium Technical Alarm	If the monitor shows the alarm [Medium Technical alarms], the external device may have the following alarms: BATTERY LOW (BEH)% O2 ERR N2O SUPPLY ? POWER FAIL SAFETY O2 ON FG LIMITED LOSS OF DATA SET.CANCELED

Monitor output: alarms from Draeger Atlan A3X0 anesthesia machine		
Priority	Label	Label
Medium	Medium Technical Alarm	<p>If the monitor shows the alarm [Medium Technical alarms], the external device may have the following alarms:</p> <p>FG TOO HIGH FG ACTIVE ABS.PRESENT? HOSES MIXED? WRONG HOSES? AIR ENTRAIN VENT PAUSE?</p>
Low	Low Technical Alarm	<p>If the monitor shows the alarm [Low Technical alarms], the external device may have the following alarms:</p> <p>N2O ERR AGT ERR RS232COM ERR PRESS ERR WATER TRAP ? GAS MON CAL VOL ERR FAN ERR GASMON.+++ N2O PRESS HI O2 CYL CO2-LINE ? PWR SPLY ERR TIDAL VOL.? INSP VOL ERR N2OCYL.SENS? AIRCYL.SENS? O2 CYL.SENS? AIR CYL.? FG AIR SENS? FG O2 SENS? FG N2O SENS?</p>

Monitor output: alarms from Draeger Atlan A3X0 anesthesia machine		
Priority	Label	Label
Low	Low Technical Alarm	If the monitor shows the alarm [Low Technical alarms], the external device may have the following alarms: PINSF? PRESS RELIEF ABSORB. OLD? ID-FUNC-INOP HOSE OLD? (A1H) % O2 ERR

3.1.3 Output Signals - Waveforms

Label	Units
Paw	cmH2O, mbar, hPa
Flow	L/min
CO2	mmHg, kPa,%
O2	%

3.2 Draeger Apollo

3.2.1 Output Signals - Parameters

Monitor output: parameters from Draeger Apollo anesthesia machine			
Labels	Units	Description	Trend, record, print
Monitoring Parameters			
PEEP	cmH2O, hPa, mbar	Positive end-expiratory pressure	Yes
Ppeak	cmH2O, hPa, mbar	Peak pressure	Yes
Pplat	cmH2O, hPa, mbar	Plateau pressure	Yes
Pmean	cmH2O, hPa, mbar	Mean pressure	Yes
TVi	ml	Inspired tidal volume	Yes
MV	L/min	Minute volume	Yes

Monitor output: parameters from Draeger Apollo anesthesia machine			
Labels	Units	Description	Trend, record, print
fspn	bpm	Spontaneous respiratory rate	Yes
Compl	ml/cmH2O,ml/ hPa,ml/mbar	Compliance	Yes
RRCO ₂	bpm	Respiratory rate of CO ₂	Yes
EtCO ₂	%,kPa,mmHg	End-tidal carbon dioxide	Yes
FiCO ₂	%,kPa,mmHg	Fraction of inspired carbon dioxide	Yes
FiO ₂	%,kPa,mmHg	Fractional concentration of O ₂ in inspired gas	Yes
EtO ₂	%,kPa,mmHg	End-tidal O ₂	Yes
ΔO ₂	%,kPa,mmHg	Difference between inspiratory and expiratory O ₂	No
Apnea Tinsp	sec	Apnea time	No
FiN ₂ O	%	Inspired anesthetic agent	Yes
Filso	%		
FiDes	%		
FiEnf	%		
FiSev	%		
FiHal	%		
EtN ₂ O	%	End-tidal anesthetic agent	Yes
EtEnf	%		
EtDes	%		
EtIso	%		
EtSev	%		
EtHal	%		
FiAA	%	Inspired anesthetic agent	Yes
EtAA	%	End-tidal anesthetic agent	Yes
FiAA 2nd	%	2nd Insp. Agent	Yes
EtAA 2nd	%	2nd Exp. Agent	Yes

Monitor output: parameters from Draeger Apollo anesthesia machine			
Labels	Units	Description	Trend, record, print
Insp. MAC	\	Inspired minimum alveolar concentration	No
Exp. MAC	\	Expired minimum alveolar concentration	No
HALlev	ml	Anesthetic agent consumption	No
ENFLev	ml		
ISOLev	ml		
DESLev	ml		
SEVLev	ml		
N ₂ O Flow	L/min	N ₂ O flow	Yes
Air Flow	L/min	Air flow	Yes
O ₂ Flow	L/min	O ₂ flow	Yes
SpO ₂	%	Arterial oxygen saturation from pulse oximetry	Yes
PR	bpm	Pulse rate	Yes
VO ₂	ml/min	Oxygen consumption	Yes
TVe	ml	Expiratory tidal volume	Yes
EtO ₂ %	%	End-tidal O ₂	Yes
FiO ₂ %	%	Fractional concentration of O ₂ in inspired gas	Yes
EtCO ₂ %	%	Fraction of inspired carbon dioxide	Yes
FiCO ₂ %	%	End-tidal carbon dioxide	Yes
ΔO ₂ %	%	Difference between inspiratory and expiratory O ₂	No
Setting Parameters			
TVi	ml	Inspired tidal volume	No
f	bpm	Breath rate	No
FreqMIN	bpm	Minimum breath frequency	No
TIP:TI	%	Percentage of inspiratory plateau time in inspiratory time	No

Monitor output: parameters from Draeger Apollo anesthesia machine			
Labels	Units	Description	Trend, record, print
Tslope	sec	Time for the pressure to rise to target pressure	No
Tinsp	sec	Time of inspiration	No
Pinsp	cmH2O, hPa, mbar	Pressure control level of inspiration	No
Δ Psupp	cmH2O, hPa, mbar	Pressure support level	No
Pmax	cmH2O, hPa, mbar	Maximal breathing pressure	No
F-Trig	L/min	Inspiratory trigger level (flow trigger)	No

3.2.2 Output Signals - Alarms

Monitor output: alarms from Draeger Apollo anesthesia machine		
Mindray Patient Monitor		Draeger Apollo Alarm
Priority	Label	Label
Physiological Alarms		
High	Apnea	Apnea/Apnea Vent
High	Volume Apnea > 2 min	Apnea Vol
High	Pressure Apnea	Apnea Pres
High	PAW High	Paw High
High	PAW Low	Paw Negative
High	FiO ₂ Low	% O2 LOW
High	CONT PRES	PEEP > Pressure Threshold for 15 sec
High	CO ₂ Apnea	Apnea CO2
High	No Pulse	SPO2 NO PULS
High	PR Low	SPO2 PULS LO
High	SpO ₂ Low	SPO2 LOW
Medium	FiO ₂ High	FiO2 High
Medium	TVe Low	TIDAL VOL?

Monitor output: alarms from Draeger Apollo anesthesia machine		
Mindray Patient Monitor		Draeger Apollo Alarm
Priority	Label	Label
Medium	MV High	MIN Vol HIGH
Medium	MV Low	MIN Vol Low
Medium	PEEP High	Peep High
Medium	EtCO ₂ High	EtCO2 High
Medium	EtCO ₂ Low	EtCO2 Low
Medium	FICO ₂ High	INSP CO2 HIGH
Medium	FIN ₂ O High	FI N2O HIGH
Medium	EtHAL High	EXP. HAL HIGH
Medium	FiHal High	%HAL HIGH
Medium	FiHal Low	%HAL Low
Medium	EtENF High	EXP. ENF HIGH
Medium	FiENF High	%ENF HIGH
Medium	FiENF Low	%ENF Low
Medium	EtISO High	EXP.ISO HIGH
Medium	FiISO High	%ISO HIGH
Medium	FiISO Low	%ISO Low
Medium	EtSEV High	EXP.SEV HIGH
Medium	FiSEV High	%SEV HIGH
Medium	FiSEV Low	%SEV Low
Medium	EtDES High	EXP.DES HIGH
Medium	FiDES High	%DES HIGH
Medium	FiDES Low	%DES Low
Medium	MAC Low	MAC Low?
Medium	PR High	SPO2 PULS HI
Medium	SpO ₂ High	SPO2 HIGH
Technical alarms		
High	O ₂ Supply Failure	O2 Supply?

Monitor output: alarms from Draeger Apollo anesthesia machine		
Mindray Patient Monitor		Draeger Apollo Alarm
Priority	Label	Label
High	No Fresh Gas	NO Freshh gas
High	Circuit Occluded	CIRCLE OCCL
High	VENT DISC	VENT DISC
High	High Technical Alarm	If the monitor shows the alarm [High Technical alarms], the external device may have the alarms: VENT ERR INT.TMP.HIGH O ₂ CYL.DISCON CHK N ₂ O CYL NO N ₂ O DELIV NO AIR DELIV FG-OVER? VENT. UNLOCK AW-TEMP HIGH NO N ₂ O NO O ₂ DELIV
Medium	Patient Circuit Leak	LEAKAGE
Medium	Fresh Gas?	FRESH GAS?
Medium	AG Module abnormal	If the monitor shows the alarm [AG Module abnormal], the external device may have the following alarms: MIXED AGENT CO ₂ /AGT ERR N ₂ O ERR AGT ERR 2ND AGENT
Medium	CO ₂ Module abnormal	If the monitor shows the alarm [CO₂ Module abnormal], the external device may have the following alarms: CO ₂ LINE BLK

Monitor output: alarms from Draeger Apollo anesthesia machine		
Mindray Patient Monitor		Draeger Apollo Alarm
Priority	Label	Label
Medium	Medium Technical Alarm	If the monitor shows the alarm [Medium Technical alarms], the external device has one or more of the following alarms: POWER FAIL BATTERY LOW N ₂ O SUPPLY? PRESSURE LIM MIXER INOP P MAX? SAFETY O ₂ ON FG FLOW LIM LOSS OF DATA % O ₂ ERR SET CANCELED FG TOO HIGH FG ACTIVE FG AIR SENS? FG O ₂ SENS? FG N ₂ O SENS?
Low	NO AIR	NO AIR
Low	NO O ₂ SUPPLY	NO O ₂ SUPPLY
Low	SpO ₂ Module abnormal	If the monitor shows the alarm [SpO₂ Module abnormal], the external device may have the following alarms: SPO ₂ SEN DISC SPO ₂ ALRM OF SPO ₂ ERR

Monitor output: alarms from Draeger Apollo anesthesia machine		
Mindray Patient Monitor		Draeger Apollo Alarm
Priority	Label	Label
Low	Low Technical Alarm	<p>If the monitor shows the alarm [Low Technical alarms], the external device may have the following alarms:</p> <p>FAN ERR PWR SPLY ERR PRESS ERR VOL ERR LO O₂ SUPPLY CHK O₂ CYL O₂ CYL OPEN N₂O CYLOPEN AIR CYL OPEN COM VENT ERR APOLLO COM1? APOLLO COM2? N₂O CYL .SENS? AIR CYL SENS? O₂ CYL .SENS? AIR CYL? PRESS RELIEF INSP VOL ERR</p>

3.2.3 Output Signals - Waveforms (For BeneVision N series Monitors)

Label	Units
Paw	cmH ₂ O, mbar, hpa
Flow	L/min
CO ₂	mmHg, kPa,%

3.3 Draeger Fabius GS/Fabius GS Premium/Fabius plus/ Fabius Tiro/Fabius plus XL

NOTE

- Only the Benevision N Series monitor supports integration with the Fabius GS Premium/Fabius plus XL anesthesia machine.

3.3.1 Output Signals - Parameters

Monitor output: parameters from Draeger Fabius GS/Fabius GS Premium/Fabius plus/ Fabius Tiro/Fabius plus XL anesthesia machine			
Labels	Units	Description	Trend, record, print
Monitoring Parameters			
PEEP	cmH2O, hPa, mbar	Positive end-expiratory pressure	Yes
Ppeak	cmH2O, hPa, mbar	Peak pressure	Yes
Pplat	cmH2O, hPa, mbar	Plateau pressure	Yes
Pmean	cmH2O, hPa, mbar	Mean pressure	Yes
TVe	ml	Expiratory tidal volume	Yes
MV	L/min	Minute volume	Yes
fspn	bpm	Spontaneous respiratory rate	Yes
RRCO ₂	bpm	Respiratory rate of CO ₂	Yes
EtCO ₂	%,kPa,mmHg	End-tidal carbon dioxide	Yes
FiCO ₂	%,kPa,mmHg	Fraction of inspired carbon dioxide	Yes
FiO ₂	%,kPa,mmHg	Fractional concentration of O ₂ in inspired gas	Yes
FiN ₂ O	%	Fraction of inspired nitrous oxide	Yes
EtN ₂ O	%	End-tidal N ₂ O	Yes
FiDes	%	Inspired anesthetic agent	Yes
FiSev	%		Yes
FiEnf	%		Yes
FiIso	%		Yes
FiHal	%		Yes

Monitor output: parameters from Draeger Fabius GS/Fabius GS Premium/Fabius plus/ Fabius Tiro/Fabius plus XL anesthesia machine			
Labels	Units	Description	Trend, record, print
EtEnf	%	End-tidal anesthetic agent	Yes
EtDes	%		Yes
EtIso	%		Yes
EtSev	%		Yes
EtHal	%		Yes
FiAA	%	Inspired anesthetic agent	Yes
EtAA	%	End-tidal anesthetic agent	Yes
N ₂ O Flow	L/min	N ₂ O flow	Yes
Air Flow	L/min	Air flow	Yes
O ₂ Flow	L/min	O ₂ flow	Yes
FiO ₂ %	%	Fractional concentration of O ₂ in inspired gas	Yes
FiCO ₂ %	%	Fraction of inspired carbon dioxide	Yes
EtCO ₂ %	%	End-tidal carbon dioxide	Yes
Setting Parameters			
TVi	ml	Inspired tidal volume	No
f	bpm	Breath rate	No
I:E	/	Inspiratory time:Expiratory time ratio	No
TIP:TI	%	Percentage of inspiratory plateau time in inspiratory time	No
Tinsp	sec	Time of inspiration	No
Pinsp	cmH ₂ O, hPa, mbar	Pressure control level of inspiration	No
ΔPsupp	cmH ₂ O, hPa, mbar	Pressure support level	No
Pmax	cmH ₂ O, hPa, mbar	Maximal breathing pressure	No
F-Trig	L/min	Inspiratory trigger level (flow trigger)	No
Insp Flow	L/min	Inspiration flow	No

3.3.2 Output Signals - Alarms

Monitor output: alarms from Draeger Fabius GS/Fabius GS Premium/Fabius plus/Fabius Tiro/Fabius plus XL anesthesia machine		
Mindray Patient Monitor		Fabius GS/GS Premium/plus/Tiro/plus XL Alarm
Priority	Label	Label
Physiological alarms		
High	Apnea	APNEA VENT
High	Volume Apnea > 2 min	APNEA VOL
High	Pressure Apnea	APNEA PRES
High	FiO ₂ Low	% O2 LOW
High	Paw High	PAW HIGH
High	Paw Low	PAW NEGATIVE
High	CONT PRES	CONT PRES
Medium	FiO ₂ High	% O2 HIGH
Medium	MV High	MIN VOL HIGH
Medium	MV Low	MIN VOL LOW
Medium	PEEP High	PEEP HIGH
Medium	PRESS EXP High	PRESS EXP High
Low	PRESSURE LIM	PRESSURE LIM
Technical alarms		
High	O ₂ Supply Failure	LO O2 SUPPLY
High	APL VALVE?	APL VALVE ?
High	No Fresh Gas	NO FRESHGAS
High	High Technical alarms	If the monitor shows the alarm [High Technical alarms], the external device may have the alarms: VENT ERR.
Medium	EXP-VALVE?	EXP-VALVE ?
Medium	FRESH GAS?	FRESH GAS ?

Monitor output: alarms from Draeger Fabius GS/Fabius GS Premium/Fabius plus/Fabius Tiro/Fabius plus XL anesthesia machine		
Mindray Patient Monitor		Fabius GS/GS Premium/plus/Tiro/plus XL Alarm
Priority	Label	Label
Medium	Medium Technical alarms	If the monitor shows the alarm [Medium Technical alarms], the external device may have the following alarms: BATTERY LOW PRESS ERR VOL ERR
Low	Low Technical alarms	If the monitor shows the alarm [Low Technical alarms], the external device may have the following alarms: SPEAKER FAIL POWER FAIL CAL% O ₂ ? % O ₂ ERR TIME LIMITED RS232COM ERR PORT 1 ERROR PORT 2 ERROR THRESHOLD LO

3.4 Draeger Perseus A500

3.4.1 Output Signals - Parameters

Monitor output: parameters from Draeger Perseus A500 anesthesia machine			
Labels	Units	Description	Trend, record, print
Monitoring Parameters			
ftotal	bpm	Total respiratory rate	Yes
RAW	cmH ₂ O/L/s,hPa/L/s,mbar/L/s	Airway resistance	Yes
VCO ₂	ml/min	CO ₂ production	No

Monitor output: parameters from Draeger Perseus A500 anesthesia machine			
Labels	Units	Description	Trend, record, print
HALLev	ml	Anesthetic agent consumption	No
ENFLev	ml		
ISOLev	ml		
DESLev	ml		
SEVLev	ml		
VO ₂	ml/min	Oxygen consumption	Yes
Pmean	cmH2O, hPa, mbar	Mean pressure	Yes
Pplat	cmH2O, hPa, mbar	Plateau pressure	Yes
PEEP	cmH2O, hPa, mbar	Positive end-expiratory pressure	Yes
Ppeak	cmH2O, hPa, mbar	Peak pressure	Yes
Insp. MAC	\	Inspired minimum alveolar concentration	No
Exp. MAC	\	Expired minimum alveolar concentration	No
FiN ₂ O	%	Inspired anesthetic agent	Yes
Filso	%		
FiDes	%		
FiEnf	%		
FiSev	%		
FiHal	%		
EtN ₂ O	%	End-tidal anesthetic agent	Yes
EtEnf	%		
EtDes	%		
Etlso	%		
EtSev	%		
EtHal	%		
MVspn	L/min	Spontaneous breathed minute volume	Yes
MV	L/min	Minute volume	Yes

Monitor output: parameters from Draeger Perseus A500 anesthesia machine			
Labels	Units	Description	Trend, record, print
Apnea T _{insp}	sec	Apnea time	No
ΔO ₂	%,kPa,mmHg	Difference between inspiratory and expiratory O ₂	No
RRCO ₂	bpm	Respiratory rate of CO ₂	Yes
FiCO ₂	%,kPa,mmHg	Fraction of inspired carbon dioxide	Yes
EtCO ₂	%,kPa,mmHg	End-tidal carbon dioxide	Yes
N ₂ O Flow	L/min	N ₂ O flow	Yes
Air Flow	L/min	Air flow	Yes
O ₂ Flow	L/min	O ₂ flow	Yes
FiAA	%	Inspired anesthetic agent	Yes
EtAA	%	End-tidal anesthetic agent	Yes
FiAA 2nd	%	2nd Insp. Agent	Yes
EtAA 2nd	%	2nd Exp. Agent	Yes
FiO ₂	%,kPa,mmHg	Fractional concentration of O ₂ in inspired gas	Yes
EtO ₂	%,kPa,mmHg	End-tidal O ₂	Yes
TVi	ml	Inspired tidal volume	Yes
FiCO ₂ %	%	Fraction of inspired carbon dioxide	Yes
EtCO ₂ %	%	End-tidal carbon dioxide	Yes
ΔO ₂ %	%	Difference between inspiratory and expiratory O ₂	No
EtO ₂ %	%	End-tidal O ₂	Yes
FiO ₂ %	%	Fractional concentration of O ₂ in inspired gas	Yes
Setting Parameters			
TVi	ml	Inspired tidal volume	No
f	bpm	Breath rate	No
T _{insp}	sec	Time of inspiration	No

Monitor output: parameters from Draeger Perseus A500 anesthesia machine			
Labels	Units	Description	Trend, record, print
PS above PEEP	cmH2O, hPa, mbar	PS above PEEP	No
Pmax	cmH2O, hPa, mbar	Maximum airway pressure	No
F-Trig	L/min	Inspiratory trigger level (flow trigger)	No
TIP:TI	%	Percentage of inspiratory plateau time in inspiratory time	No
Tslope	sec	Time for the pressure to rise to target pressure	No
FG	ml/min	Fresh gas flow	No
Pinsp	cmH2O, hPa, mbar	Pressure control level of inspiration	No
PEEP	cmH2O, hPa, mbar	Positive end-expiratory pressure	No

3.4.2 Output Signals - Alarms

Monitor output: alarms from Draeger A500 anesthesia machine		
Mindray Patient Monitor		Draeger A500 Alarm
Priority	Label	Label
Physiological alarms		
High	Apnea	APNEA or APNEA VOL
High	FiO ₂ Low	%O ₂ LOW
High	CO ₂ Apnea	APNEA CO ₂
High	Pressure Apnea	APNEA PRES
High	Paw High	PAW HIGH
High	Paw Low	PAW LOW / PAW NEGATIVE
High	CONT PRES	CONT PRES
Medium	FiHal High	% HAL HIGH
Medium	FiEnf High	% ENF HIGH
Medium	Filso High	% ISO HIGH

Monitor output: alarms from Draeger A500 anesthesia machine		
Mindray Patient Monitor		Draeger A500 Alarm
Priority	Label	Label
Medium	MV Low	MIN VOL LOW
Medium	FiSev High	% SEV HIGH
Medium	FiDes High	% DES HIGH
Medium	EtCO ₂ Low	ET CO2 LOW
Medium	EtCO ₂ High	ET CO2 HIGH
Medium	FiHal Low	% HAL LOW
Medium	FiEnf Low	% ENF LOW
Medium	Filso Low	% ISO LOW
Medium	FiDes Low	% DES LOW
Medium	FiSev Low	% SEV LOW
Medium	FiCO ₂ High	INSP CO2 HI
Medium	MV High	MIN VOL HIGH
Medium	PEEP High	PEEP HIGH
Medium	TVe High	TIDAL VOL HI
Medium	MAC Low	MAC LOW?
Medium	FiN ₂ O High	% N2O HIGH
Technical alarms		
High	O ₂ Supply Failure	O2 SUPPLY?
High	NO Fresh Gas	NO FRESHGAS
High	VENT DISC	VENT ASSEMBL

Monitor output: alarms from Draeger A500 anesthesia machine		
Mindray Patient Monitor		Draeger A500 Alarm
Priority	Label	Label
High	High Technical Alarm	If the monitor shows the alarm [High Technical alarms], the external device may have the following alarms: VENT ERR MIXER INOP INT.TMP.HIGH AIR PRESS HI HI O ₂ SUPPLY SYSTEM FAULT N ₂ O CYL.? NO N ₂ O NO OXYGEN NO AIR FG EXTERN?
Medium	FRESH GAS?	FRESH GAS?
Medium	EXP-VALVE?	EXP-VALVE?
Medium	Medium Technical Alarm	If the monitor shows the alarm [Medium Technical alarms], the external device may have the following alarms: BATTERY LOW % O ₂ ERR N ₂ O SUPPLY? POWER FAIL SAFETY O ₂ ON FG LIMITED LOSS OF DATA SET.CANCELED FG TOO HIGH FG ACTIVE ABS.PRESENT?
Medium	Medium Technical Alarm	HOSES MIXED? WRONG HOSES? AIR ENTRAIN VENT PAUSE?

Monitor output: alarms from Draeger A500 anesthesia machine		
Mindray Patient Monitor		Draeger A500 Alarm
Priority	Label	Label
Medium	CO ₂ Module abnormal	If the monitor shows the alarm [CO2 Module abnormal], the external device may have the alarm: CO ₂ LINE BLK
Medium	AG Module abnormal	If the monitor shows the alarm [AG Module abnormal], the external device may have the following alarms: MIXED AGENT CO2 AGT ERR 2nd AGENT WATERTR.OLD?
Low	Low Technical Alarm	If the monitor shows the alarm [Low Technical alarms], the external device may have the following alarms: RS232COM ERR PRESS ERR WATER TRAP ? VENT TEMP HI VOL ERR FAN ERR N ₂ O PRESS HI O ₂ CYL. ? VOLAT SUPPLY CO ₂ -LINE ? PWR SPLY ERR TIDAL VOL.? INSP VOL ERR N ₂ OCYL.SENS? AIRCYL.SENS? O ₂ CYL.SENS? AIR CYL.? PMIN REACHED
Low	Low Technical Alarm	PRESS RELIEF ABSORB. OLD? ID-FUNC-INOP HOSE OLD?

3.4.3 Output Signals - Waveforms (For BeneVision N series Monitors)

Label	Units
Paw	cmH2O, mbar, hpa
Flow	L/min
CO2	mmHg, kPa, %
O2	%

3.5 Draeger Primus/Primus Infinity

NOTE

- Only the Benevision N Series monitor supports integration with the Draeger Primus Infinity anesthesia machine.

3.5.1 Output Signals - Parameters

Monitor output: parameters from Draeger Primus anesthesia machine			
Labels	Units	Description	Trend, record, print
Monitoring Parameters			
PEEP	cmH2O, hPa, mbar	Positive end-expiratory pressure	Yes
Ppeak	cmH2O, hPa, mbar	Peak pressure	Yes
Pplat	cmH2O, hPa, mbar	Plateau pressure	Yes
Pmean	cmH2O, hPa, mbar	Mean pressure	Yes
TVe	ml	Expiratory tidal volume	Yes
TVi	ml	Inspired tidal volume	Yes
MV	L/min	Minute volume	Yes
fspn	bpm	Spontaneous respiratory rate	Yes
Compl	ml/cmH2O,ml/hPa,ml/mbar	Compliance	Yes
RRCO ₂	bpm	Respiratory rate of CO ₂	Yes
EtCO ₂	%,kPa,mmHg	End-tidal carbon dioxide	Yes

Monitor output: parameters from Draeger Primus anesthesia machine			
Labels	Units	Description	Trend, record, print
FiCO ₂	%,kPa,mmHg	Fraction of inspired carbon dioxide	Yes
FiO ₂	%,kPa,mmHg	Fractional concentration of O ₂ in inspired gas	Yes
EtO ₂	%,kPa,mmHg	End-tidal O ₂	Yes
ΔO ₂	%,kPa,mmHg	Difference between inspiratory and expiratory O ₂	No
Apnea T _{insp}	sec	Apnea time	No
FiN ₂ O	%	Inspired anesthetic agent	Yes
Filso	%		Yes
FiDes	%		Yes
FiEnf	%		Yes
FiSev	%		Yes
FiHal	%		Yes
EtN ₂ O	%		End-tidal anesthetic agent
EtEnf	%	Yes	
EtDes	%	Yes	
EtIso	%	Yes	
EtSev	%	Yes	
EtHal	%	Yes	
FiAA	%	Inspired anesthetic agent	
EtAA	%	End-tidal anesthetic agent	Yes
FiAA 2nd	%	2nd Insp. Agent	Yes
EtAA 2nd	%	2nd Exp. Agent	Yes
Insp. MAC	\	Inspired minimum alveolar concentration	No
Exp. MAC	\	Expired minimum alveolar concentration	No

Monitor output: parameters from Draeger Primus anesthesia machine			
Labels	Units	Description	Trend, record, print
HALLev	ml	Anesthetic agent consumption	No
ENFLev	ml		
ISOLev	ml		
DESLev	ml		
SEVLev	ml		
VO ₂	ml/min	Oxygen consumption	Yes
N ₂ O Flow	L/min	N ₂ O flow	Yes
Air Flow	L/min	Air flow	Yes
O ₂ Flow	L/min	O ₂ flow	Yes
SpO ₂	%	Arterial oxygen saturation from pulse oximetry	Yes
PR	bpm	Pulse rate	Yes
FiO ₂ %	%	Fractional concentration of O ₂ in inspired gas	Yes
EtO ₂ %	%	End-tidal O ₂	Yes
ΔO ₂ %	%	Difference between inspiratory and expiratory O ₂	No
FiCO ₂ %	%	Fraction of inspired carbon dioxide	Yes
EtCO ₂ %	%	End-tidal carbon dioxide	Yes
Setting Parameters			
f	bpm	Breath rate	No
FreqMIN	bpm	Minimum breath frequency	No
TIP:TI	%	Percentage of inspiratory plateau time in inspiratory time	No
Tslope	sec	Time for the pressure to rise to target pressure	No
Tinsp	sec	Time of inspiration	No
Pinsp	cmH ₂ O, hPa, mbar	Pressure control level of inspiration	No
ΔPsupp	cmH ₂ O, hPa, mbar	Pressure support level	No

Monitor output: parameters from Draeger Primus anesthesia machine			
Labels	Units	Description	Trend, record, print
Pmax	cmH2O, hPa, mbar	Maximal breathing pressure	No
F-Trig	L/min	Inspiratory trigger level (flow trigger)	No
TVi	ml	Inspired tidal volume	No
FG	ml/min	Fresh gas flow	No

3.5.2 Output Signals - Alarms

Monitor output: alarms from Draeger Primus anesthesia machine		
Mindray Patient Monitor		Draeger Primus Alarm
Priority	Label	Label
Physiological alarms		
High	Apnea	APNEA/APNEA VENT
High	Volume Apnea > 2 min	APNEA VOL
High	Pressure Apnea	APNEA PRES
High	Paw High	PAW HIGH
High	Paw Low	PAW NEGATIVE
High	FiO ₂ Low	%O ₂ LOW
High	CONT PRES	CONT PRES
High	CO ₂ Apnea	APNEA CO ₂
High	No Pulse	NO SPO ₂ PULS
High	PR Low	SPO ₂ PULS LO
High	SPO ₂ Low	SPO ₂ LOW
Medium	FiO ₂ High	%O ₂ HIGH
Medium	TVe Low	VT LOW
Medium	MV High	MIN VOL HIGH
Medium	MV Low	MIN VOL LOW
Medium	PEEP High	PEEP HIGH

Monitor output: alarms from Draeger Primus anesthesia machine		
Mindray Patient Monitor		Draeger Primus Alarm
Priority	Label	Label
Medium	EtCO ₂ High	ET CO2 HIGH
Medium	EtCO ₂ Low	ET CO2 Low
Medium	FiCO ₂ High	INSP CO2 HIGH
Medium	FiN ₂ O High	FI N2O HIGH
Medium	EtHal High	EXP. HAL HIGH
Medium	FiHal High	% HAL HIGH
Medium	FiHal Low	% HAL LOW
Medium	EtEnf High	EXP. ENF HIGH
Medium	FiEnf High	% ENF HIGH
Medium	FiEnf Low	% ENF LOW
Medium	EtIso High	EXP. ISO HIGH
Medium	FiIso High	% ISO HIGH
Medium	FiIso Low	% ISO LOW
Medium	EtSev High	EXP. SEV HIGH
Medium	FiSev High	% SEV HIGH
Medium	FiSev Low	% SEV LOW
Medium	EtDes High	EXP. DES HIGH
Medium	FiDes High	% DES HIGH
Medium	FiDes Low	% DES LOW
Medium	MAC Low	MAC LOW?
Medium	PR High	SPO2 PULS HI
Medium	SpO ₂ High	SPO2 HIGH
Technical alarms		
High	O ₂ Supply Failure	O2 SUPPLY ?
High	No Fresh Gas	NO FRESHGAS
High	Circuit Occluded	CIRCLE OCCL
High	VENT DISC	VENT DISC

Monitor output: alarms from Draeger Primus anesthesia machine		
Mindray Patient Monitor		Draeger Primus Alarm
Priority	Label	Label
High	High Technical alarms	If the monitor shows the alarm [High Technical alarms], the external device may have the following alarms: VENT ERR INT.TMP.HIGH O ₂ CYL.DISCON CHK N ₂ O CYL NO N ₂ O DELIV NO O ₂ DELIV. NO AIR DELIV FG X-OVER ? VENT.UNLOCKD AW-TEMP HIGH NO N ₂ O
Medium	Patient Circuit Leak	LEAKAGE
Medium	FRESH GAS?	FRESH GAS?
Medium	Medium Technical alarms	If the monitor shows the alarm [Medium Technical alarms], the external device may have the following alarms: POWER FAIL BATTERY LOW N ₂ O SUPPLY? PRESSURE LIM MIXER INOP P MAX SAFETY O ₂ ON FG.FLOW LIM. LOSS OF DATA HOSES MIXED? WRONG HOSES? % O ₂ ERR SET.CANCELED FG TOO HIGH FG ACTIVE FG AIR SENS?

Monitor output: alarms from Draeger Primus anesthesia machine		
Mindray Patient Monitor		Draeger Primus Alarm
Priority	Label	Label
Medium	Medium Technical alarms	If the monitor shows the alarm [Medium Technical alarms], the external device may have the following alarms: FG O ₂ SENS? FG N ₂ O SENS? ABS. PRESENT?
Medium	AG Module abnormal	If the monitor shows the alarm [AG Module abnormal], the external device may have the following alarms: WATERTR. OLD? MIXED AGENT CO ₂ /AGT ERR N ₂ O ERR AGT ERR 2nd AGENT
Medium	CO2 Module abnormal	If the monitor shows the alarm [CO2 Module abnormal], the external device may have the following alarm: CO ₂ LINE BLK
Low	NO AIR	NO AIR
Low	NO O ₂ SUPPLY	NO O2 SUPPLY
Low	Low Technical alarms	If the monitor shows the alarm [Low Technical alarms], the external device may have the following alarms: FAN ERR PWR SPLY ERR PRESS ERR VOL ERR LO O ₂ SUPPLY CHK O ₂ CYL ID-FUNC-INOP HOSE OLD? HOSE MISSING COM VENT ERR

Monitor output: alarms from Draeger Primus anesthesia machine		
Mindray Patient Monitor		Draeger Primus Alarm
Priority	Label	Label
Low	Low Technical alarms	If the monitor shows the alarm [Low Technical alarms], the external device may have the following alarms: APOLLO COM1? APOLLO COM2? N ₂ OCYL.SENS? AIRCYL.SENS? O ₂ CYL.SENS? AIR CYL.? PRESS RELIEF ABSORB. OLD? INSP VOL ERR
Low	SpO ₂ Module abnormal	If the monitor shows the alarm [SpO₂ Module abnormal], the external device may have the following alarms: SPO ₂ SEN DISC SPO ₂ ALRM OF SPO ₂ ERR

3.5.3 Output Signals - Waveforms (For BeneVision N series Monitors)

Label	Units
Paw	cmH ₂ O, mbar, hpa
Flow	L/min
CO ₂	mmHg, kPa, %

3.6 Draeger Zeus/ZeusIE

3.6.1 Output Signals - Parameters

Monitor output: parameters from Draeger Zeus/ZeusIE anesthesia machine			
Labels	Units	Description	Trend, record, print
Monitoring Parameters			
FiO ₂	%,kPa,mmHg	Fractional concentration of O ₂ in inspired gas	Yes
EtO ₂	%,kPa,mmHg	End-tidal O ₂	Yes
FiN ₂ O	%	Inspired anesthetic agent	Yes
Filso	%		
FiDes	%		
FiEnf	%		
FiSev	%		
FiHal	%		
EtN ₂ O	%		
EtEnf	%		
EtDes	%		
EtIso	%		
EtSev	%		
EtHal	%		
FiAA	%	Inspired anesthetic agent	Yes
EtAA	%	End-tidal anesthetic agent	Yes
FiAA 2nd	%	2nd Insp. Agent	Yes
EtAA 2nd	%	2nd Exp. Agent	Yes
Exp. MAC	\	Expired minimum alveolar concentration	No
Pmean	cmH ₂ O, hPa, mbar	Mean pressure	Yes
Pplat	cmH ₂ O, hPa, mbar	Plateau pressure	Yes
PEEP	cmH ₂ O, hPa, mbar	Positive end-expiratory pressure	Yes

Monitor output: parameters from Draeger Zeus/ZeusE anesthesia machine			
Labels	Units	Description	Trend, record, print
MVspn	L/min	Spontaneous breathed minute volume	Yes
Ppeak	cmH2O, hPa, mbar	Peak pressure	Yes
TVe	ml	Expiratory tidal volume	Yes
TVi	ml	Inspired tidal volume	Yes
Mvleak	L/min	Leakage minute volume	No
MV	L/min	Minute volume	Yes
RRCO ₂	bpm	Respiratory rate of CO ₂	Yes
fspn	bpm	Spontaneous respiratory rate	Yes
EtCO ₂	%,kPa,mmHg	End-tidal carbon dioxide	Yes
FiCO ₂	%,kPa,mmHg	Fraction of inspired carbon dioxide	Yes
RAW	cmH2O/L/s,hPa/L/s,mbar/L/s	Airway resistance	Yes
ISOLev	ml	Anesthetic agent consumption	No
DESLev	ml		
SEVLev	ml		
SpO ₂	%	Arterial oxygen saturation from pulse oximetry	Yes
BIS	\	Bispectral index	Yes
EMG	dB	Electromyograph	Yes
SQI	%	Signal quality index	Yes
SR	%	Suppression ratio	Yes
SEF	Hz	Spectral edge frequency	Yes
TP	dB	Total power	Yes
BC	/min	Burst count	Yes
FiO ₂ %	%	Fractional concentration of O ₂ in inspired gas	Yes
EtO ₂ %	%	End-tidal O ₂	Yes
FiCO ₂ %	%	Fraction of inspired carbon dioxide	Yes

Monitor output: parameters from Draeger Zeus/ZeusE anesthesia machine			
Labels	Units	Description	Trend, record, print
EtCO2%	%	End-tidal carbon dioxide	Yes
PO2	kPa	oxygen supply pressure	No
N2O Flow	L/min	N2O flow	Yes
Air Flow	L/min	Air flow	Yes
O2 Flow	L/min	O2 flow	Yes
Setting Parameters			
T _{insp}	sec	Time of inspiration	No
T _{exp}	sec	Expiratory time	No
P _{max}	cmH2O, hPa, mbar	Maximal breathing pressure	No
F-Trig	L/min	Inspiratory trigger level (flow trigger)	No
TIP:TI	%	Percentage of inspiratory plateau time in inspiratory time	No
P _{insp}	cmH2O, hPa, mbar	Pressure control level of inspiration	No
f	bpm	Breath rate	No
FG	ml/min	Fresh gas flow	No
T _{slope}	sec	Time for the pressure to rise to target pressure	No
ΔP _{supp}	cmH2O, hPa, mbar	Pressure support level	No
I:E	\	Percentage of inspiratory plateau time in inspiratory time	No
PS above PEEP	cmH2O, hPa, mbar	PS above PEEP	No
TV _i	ml	Inspired tidal volume	No

3.6.2 Output Signals - Alarms

Monitor output: alarms from Draeger Zeus/Zeus IE anesthesia machine		
Mindray Patient Monitor		Draeger Zeus/Zeus IE Alarm
Priority	Label	Label
Physiological alarms		
High	Apnea	APNEA or APNEA VOL
High	Pressure Apnea	APNEA PRES
High	Paw Low	PAW LOW or PAW NEGATIVE
High	Paw High	PAW HIGH
High	CONT PRES	CONT PRES
High	CO ₂ Apnea	APNEA CO2
High	FiO2 Low	%O2 LOW
High	No Pulse	SPO2 NO PULS
High	SpO2 Low	SPO2 LOW
Medium	FiHal High	% HAL HIGH
Medium	FiEnf High	% ENF HIGH
Medium	Filso High	% ISO HIGH
Medium	FiSev High	% FISEV HIGH
Medium	FiDes High	% FIDES HIGH
Medium	FiHal Low	% Fihal LOW
Medium	FiEnf Low	%FIENF LOW
Medium	Filso Low	%FIISO LOW
Medium	FiSev Low	% FISEV LOW
Medium	FiDes Low	% FIDES LOW
Medium	FiN ₂ O High	% N2O HIGH
Medium	FiN ₂ O Low	% N2O LOW
Medium	FiAA High	INSP AGT.HI.
Medium	MV Low	MIN VOL LOW
Medium	MV High	MIN VOL HIGH
Medium	PEEP High	PEEP HIGH

Monitor output: alarms from Draeger Zeus/Zeus IE anesthesia machine		
Mindray Patient Monitor		Draeger Zeus/Zeus IE Alarm
Priority	Label	Label
Medium	TVe High	TIDAL VOL HI
Medium	SpO2 High	SPO2 HIGH
Medium	BIS High	BISX HIGH
Medium	BIS Low	BISX LOW
Medium	EtCO ₂ High	ET CO2 HIGH
Medium	EtCO ₂ Low	ET CO2 LOW
Medium	FiCO ₂ High	INSP CO2 HI
Medium	FiO ₂ High	%O2 HIGH
Low	PRESSURE LIM	PRESS LIM
Technical alarms		
High	High Technical Alarm	If the monitor shows the alarm [High Technical alarms], the external device may have the following alarms: INT COM ERR COM VENT ERR INT.TMP,HIGH POWER FAIL VENT ERR VA+MIX ERR MIXER ERR O ₂ CYL. ? N ₂ O CYL.?
High	No Fresh Gas	NO FRESHGAS
High	O ₂ Supply Failure	O2 SUPPLY FAIL

Monitor output: alarms from Draeger Zeus/Zeus IE anesthesia machine		
Mindray Patient Monitor		Draeger Zeus/Zeus IE Alarm
Priority	Label	Label
Medium	Medium Technical Alarm	If the monitor shows the alarm [Medium Technical alarms], the external device may have the following alarms: WRONG AGENT FLOW SENSOR? PRESS ERR VOL ERR BATTERY LOW % O ₂ ERR PS LIMITED MIXER INOP N ₂ O SUPPLY? SAFETY O ₂ ON NO AIR FG-FLOW HIGH
Medium	CO ₂ Module abnormal	If the monitor presents the alarm [CO₂ Module abnormal], the external device may present the alarm: CO ₂ LINE BLK
Medium	Fresh Gas	LEAK_GAS_LOW
Medium	AG Module abnormal	If the monitor shows the alarm [AG Module abnormal], the external device may have the following alarms: MIX AGENT N ₂ O ERR AGT ERR TOW AGENT
Low	No O ₂ Supply	NO O ₂ DELIV
Low	SpO ₂ Module abnormal	If the monitor shows the alarm [SpO₂ Module abnormal], the external device may have the following alarms: SpO ₂ SEN DISC SpO ₂ ERR

Monitor output: alarms from Draeger Zeus/Zeus IE anesthesia machine		
Mindray Patient Monitor		Draeger Zeus/Zeus IE Alarm
Priority	Label	Label
Low	Low Technical Alarm	If the monitor shows the alarm [Low Technical alarms], the external device may have the following alarms: AIR TRAPPING CO ₂ -LINE? NO N ₂ O PBAG INOP BIS INOP BIS SENS? BISX OUT RANGE

3.6.3 Output Signals - Waveforms (For BeneVision N series Monitors)

Label	Units
Paw	cmH ₂ O, mbar, hpa
Flow	L/min
CO ₂	mmHg, kPa,%
O ₂	%

3.7 GE Aespire 7900&7100/ Aestiva 7900&7100

3.7.1 Output Signals - Parameters

Monitor output: parameters from GE Aespire 7900&7100/ Aestiva 7900&7100 anesthesia machine			
Labels	Units	Description	Trend, record, print
Monitoring Parameters			
TVe	ml	Expiratory tidal volume	Yes
MVe	L/min	Expiratory minute volume	Yes
O ₂ %	%	Oxygen concentration	Yes
Ppeak	cmH ₂ O, hPa, mbar	Peak pressure	Yes
Pplat	cmH ₂ O, hPa, mbar	Plateau pressure	Yes
Pmean	cmH ₂ O, hPa, mbar	Mean pressure	Yes
Pmin	cmH ₂ O, hPa, mbar	Minimum airway pressure	No
ftotal	bpm	Total respiratory rate	Yes
Setting Parameters			
TV	ml	Tidal volume	No
f	bpm	Breath rate	No
I:E	/	Percentage of inspiratory plateau time in inspiratory time	No
TIP:TI	%	Percentage of inspiratory plateau time in inspiratory time	No
PEEP	cmH ₂ O, hPa, mbar	Positive end-expiratory pressure	No
Plimit	cmH ₂ O, hPa, mbar	Pressure limit level	No
Pinsp	cmH ₂ O, hPa, mbar	Pressure control level of inspiration	No

3.7.2 Output Signals - Alarms

Monitor output: alarms from GE Aespire 7900&7100/Aestiva 7900&7100 anesthesia machine		
Mindray Patient Monitor		Aespire 7900&7100/Aestiva 7900&7100 Alarm
Priority	Label	Label
Physiological alarms		
High	FiO ₂ Low	Low O ₂
High	Paw High	High Paw
High	Paw Low	Low Paw
High	High Paw Sustained	Sustained Paw (shutdown)
High	Volume Apnea > 2 min	Volume Apnea > 2 min
Medium	FiO ₂ High	High O ₂
Medium	Sub-Atmospheric Paw	Sub-Atmospheric Paw
Medium	MV Low	Low VE
Medium	MV High	High VE
Medium	TVe Low	Low Vte
Medium	TVe High	High Vte
Medium	Volume Apnea	Volume Apnea
Low	Pressure limiting	Sustained Paw
Technical alarms		
High	No Fresh Gas	No Fresh Gas Flow
High	O ₂ Supply Failure	No O ₂ Pressure
High	High Technical alarms	<p>If the monitor shows the alarm [High Technical alarms], the external device may have the following alarms:</p> <ul style="list-style-type: none"> Pinspired Not Achieved Inspiration Stopped +15V SIB Out-of-Range +15V Manifold Out-of-Range Display Voltage Out-of-Range Vaux_ref Out-of-Range Vext_ref Out-of-Range

Monitor output: alarms from GE Aespire 7900&7100/Aestiva 7900&7100 anesthesia machine		
Mindray Patient Monitor		Aespire 7900&7100/Aestiva 7900&7100 Alarm
Priority	Label	Label
High	High Technical alarms	<p>If the monitor shows the alarm [High Technical alarms], the external device may have the following alarms:</p> <ul style="list-style-type: none"> A/D Converter Failure CPU Failure Memory (EEPROM) Failure Memory (flash) Failure Memory (RAM) Failure Memory (video) Failure Bootup Memory Failure Software Watchdog Failure Hardware Watchdog Failure Internal Clock Too Fast Internal Clock Too Slow CPU Internal Error Control Settings Input Has Failed
Medium	Medium Technical alarms	<p>If the monitor shows the alarm [Medium Technical alarms], the external device may have the following alarms:</p> <ul style="list-style-type: none"> No Pressure Mode/PEEP Inspiratory Overshoot Manifold Pressure Sensor Failure High Pressure Limit Reached (min sys) Inspiratory Reverse Flow Expiratory Reverse Flow Check Flow Sensors Flow Valve Failure Gas Inlet Valve Failure Bootup Gas Inlet Valve Failure Memory (redundant storage) Fail No Battery Low Battery Charge Low VE Limit Set.
Low	Battery in Use	On Battery

Monitor output: alarms from GE Aespire 7900&7100/Aestiva 7900&7100 anesthesia machine		
Mindray Patient Monitor		Aespire 7900&7100/Aestiva 7900&7100 Alarm
Priority	Label	Label
Low	Low Technical alarms	<p>If the monitor shows the alarm [Low Technical alarms], the external device may have the following alarms:</p> <ul style="list-style-type: none"> Check O₂ Sensor O₂ Calibration Error PEEP Not Achieved Vt Not Achieved No Inspiratory Flow Sensor No Expiratory Flow Sensor Insp Vt/Vte Mismatch Vdel Mismatch Bellows Empty +Vanalog Failure -Vanalog Failure Flow Sensor Cal Data Corrupt Low Battery Low Battery (shutdown) Battery Voltage Out Of Range Battery Current Out Of Range Circuit Auxiliary Auxiliary Breathing Circuit Service Calibrations Due

3.7.3 Output Signals - Waveforms (For BeneVision N series Monitors)

Label	Units
Paw	cmH ₂ O, mbar, hpa
Flow	L/min

3.8 GE AespireView

3.8.1 Output Signals - Parameters

Monitor output: parameters from GE AespireView anesthesia machine			
Labels	Units	Description	Trend, record, print
Monitoring Parameters			
TVe	ml	Expiratory tidal volume	Yes
MVe	L/min	Expiratory minute volume	Yes
ftotal	bpm	Total respiratory rate	Yes
O ₂ %	%	Oxygen concentration	Yes
Ppeak	cmH ₂ O, hPa, mbar	Peak pressure	Yes
Pplat	cmH ₂ O, hPa, mbar	Plateau pressure	Yes
Pmean	cmH ₂ O, hPa, mbar	Mean pressure	Yes
Pmin	L/min	Minimum airway pressure	No
MVspn	bpm	Spontaneous breathed minute volume	Yes
fspn	ml	Spontaneous respiratory rate	Yes
TVi	L/min	Inspired tidal volume	Yes
MVi	cmH ₂ O, hPa, mbar	Inspiratory minute volume	Yes
PEEPtot	mmHg	Total PEEP	No
ATMP	L/min	Barometric pressure	No
O ₂ Flow	L/min	O ₂ flow	Yes
N ₂ O Flow	ml	N ₂ O flow	Yes
Air Flow	L/min	Air flow	Yes
Setting Parameters			
TV	ml	Tidal volume	No
f	bpm	Breath rate	No
I:E	\	Inspiratory time:Expiratory time ratio	No
TIP:TI	%	Percentage of inspiratory plateau time in inspiratory time	No

Monitor output: parameters from GE AespireView anesthesia machine			
Labels	Units	Description	Trend, record, print
PEEP	cmH2O, hPa, mbar	Positive end-expiratory pressure	No
Plimit	cmH2O, hPa, mbar	Pressure limit level	No
Pinsp	cmH2O, hPa, mbar	Pressure control level of inspiration	No
Δ Psupp	cmH2O, hPa, mbar	Pressure support level	No
F-Trig	L/min	Inspiratory trigger level (flow trigger)	No
Tinsp	sec	Time of inspiration	No

3.8.2 Output Signals - Alarms

Monitor output: alarms from GE AespireView anesthesia machine		
Mindray Patient Monitor		GE AespireView Alarm
Priority	Label	Label
High	Paw High	pPeak High
High	Paw Low	pPeak Low
High	Volume Apnea > 2 min	Volume Apnea > 2 min
Medium	Sub-Atmospheric Paw	Sub-Atmospheric Paw
Medium	MV Low	Low VE
Medium	MV High	High VE
Medium	TVe Low	Low Vte
Medium	TVe High	High Vte
Medium	Volume Apnea	Volume Apnea
Low	Pressure Limiting	Sustained Paw
Technical alarms		
High	No Fresh Gas	No Fresh Gas Flow
High	O ₂ Supply Failure	No O2 Pressure

Monitor output: alarms from GE AespireView anesthesia machine		
Mindray Patient Monitor		GE AespireView Alarm
Priority	Label	Label
High	High Technical alarms	<p>If the monitor shows the alarm [High Technical alarms], the external device may have the following alarms:</p> <ul style="list-style-type: none"> Other Priority Alarms Ventilator Has No Diver Gas Battery Charging Low Battery Voltage Manifold Pressure Sensor Failure Pressure Limit Switch Failure Flow Valve Failure Valve Power Failure No Insp flow sensor No Exp flow Sensor Replace exp flow Replace Insp Flow Sensor
Medium	Patient Circuit Leak	Patient Circuit Leak
Medium	Medium Technical alarms	<p>If the monitor shows the alarm [Medium Technical alarms], the external device may have the following alarms:</p> <ul style="list-style-type: none"> High Circuit O₂ Low Circuit O₂ No O₂ Cell Sensor No Pressure Cntrl/PEEP Inspiration Stopped Inspiratory Reverse Flow Expiratory Reverse Flow Check Flow Sensors No Air Pressure Battery Failure Battery Failure High Battery Current High ACGO On Increase Low MV Limit Display Failure Loss of Backup Audio
Low	Battery in Use	Running On Battery (No AC)

Monitor output: alarms from GE AespireView anesthesia machine		
Mindray Patient Monitor		GE AespireView Alarm
Priority	Label	Label
Low	Low Technical alarms	If the monitor shows the alarm [Low Technical alarms], the external device may have the following alarms: Replace O ₂ Cell O ₂ Cell Calibration Error Vt Not Achieved No Inspiratory Flow Sensor No Expiratory Flow Sensor Dry or Replace Sensors System Leak? Unable to drive bellows Memory (EEPROM) Failure

3.8.3 Output Signals - Waveforms (For BeneVision N series Monitors)

Label	Units
Paw	cmH ₂ O, mbar, hpa
Flow	L/min
Vol	mL

3.8.4 Output Signals - Respiratory Loops (For BeneVision N series Monitors)

Label	Units
PV Loop	cmH ₂ O/ml, hPa/ml, mbar/ml
FV Loop	L/min/ml
PF Loop	cmH ₂ O/L/min, hPa/L/min, mbar/L/min

3.9 GE Aisys/Aisys CS2/Avance/Avance CS2/Carestation 650/620

NOTE

- Only the Benevision N Series monitor supports integration with the GE Carestation 650/620/Avance CS2 anesthesia machine.

3.9.1 Output Signals - Parameters

Monitor output: parameters from GE Aisys/Aisys CS2/Avance/Carestation 650/620/Avance CS2 anesthesia machine			
Labels	Units	Description	Trend, record, print
Monitoring Parameters			
TVe	ml	Expiratory tidal volume	Yes
MVe	L/min	Expiratory minute volume	Yes
ftotal	bpm	Total respiratory rate	Yes
O ₂ %	%	Oxygen concentration	Yes
Ppeak	cmH2O, hPa, mbar	Peak pressure	Yes
Pplat	cmH2O, hPa, mbar	Plateau pressure	Yes
Pmean	cmH2O, hPa, mbar	Mean pressure	Yes
Pmin	cmH2O, hPa, mbar	Minimum airway pressure	No
MVspn	L/min	Spontaneous breathed minute volume	Yes
fspn	bpm	Spontaneous respiratory rate	Yes
PEEPi	cmH2O, hPa, mbar	Intrinsic positive end-expiratory pressure	No
Compl	ml/cmH2O,ml/hPa,ml/mbar	Compliance	Yes
RAW	cmH2O/L/s,hPa/L/s,mbar/L/s	Airway resistance	Yes
TVi	ml	Inspired tidal volume	Yes
MVi	L/min	Inspiratory minute volume	Yes

Monitor output: parameters from GE Aisys/Aisys CS2/Avance/Carestation 650/620/Avance CS2 anesthesia machine			
Labels	Units	Description	Trend, record, print
Paux Peak	cmH2O, hPa, mbar	Peak auxiliary pressure	No
Paux Mean	cmH2O, hPa, mbar	Mean auxiliary pressure	No
Paux Min	cmH2O, hPa, mbar	Minimum auxiliary pressure	No
PEEPe	cmH2O, hPa, mbar	Extrinsic positive end-expiratory pressure	No
PEEPtot	cmH2O, hPa, mbar	Total PEEP	No
PEEPi time	min	Intrinsic PEEP age (elapsed time since last maneuver)	No
P0.1	cmH2O, hPa, mbar	100 ms occlusion pressure	No
P0.1 time	min	P0.1 age (elapsed time since last maneuver)	No
ATMP	mmHg	Barometric pressure	No
FiO ₂	%,kPa,mmHg	Fractional concentration of O ₂ in inspired gas	Yes
EtO ₂	%,kPa,mmHg	End-tidal O ₂	Yes
ΔO ₂	%,kPa,mmHg	Difference between inspiratory and expiratory O ₂	No
FiCO ₂	%,kPa,mmHg	Fraction of inspired carbon dioxide	Yes
EtCO ₂	%,kPa,mmHg	End-tidal carbon dioxide	Yes
RRCO ₂	bpm	Respiratory rate of CO ₂	Yes
FiAA	%	Inspired anesthetic agent	Yes
EtAA	%	End-tidal anesthetic agent	Yes
FiAA 2nd	%	2nd Insp. Agent	Yes
EtAA 2nd	%	2nd Exp. Agent	Yes
FiN ₂ O	%	Fraction of inspired nitrous oxide	Yes
EtN ₂ O	%	End-tidal N ₂ O	Yes
MAC	\	Minimum alveolar concentration	Yes
VO ₂	ml/min	Oxygen consumption	Yes

Monitor output: parameters from GE Aisys/Aisys CS2/Avance/Carestation 650/620/Avance CS2 anesthesia machine			
Labels	Units	Description	Trend, record, print
VO ₂ /m ²	ml/min/m ²	Oxygen consumption per body surface area	No
VO ₂ /kg	ml/min/kg	Oxygen consumption per body weight	No
VCO ₂	ml/min	CO ₂ production	No
EE	kcal/day	Energy expenditure	No
RQ	\	Respiratory quotient	No
PO ₂	kPa	oxygen supply pressure	No
PN ₂ O	kPa	N ₂ O supply pressure	No
Pair	kPa	air supply pressure	No
O ₂ cyl.	kPa	Oxygen cylinder pressure	No
O ₂ cyl.2nd	kPa	Secondary oxygen cylinder pressure	No
N ₂ O cyl.	kPa	N ₂ O cylinder pressure	No
air cyl.	kPa	Air cylinder pressure	No
Des flow	ml/h	Anesthetic agent flow	No
Enf flow	ml/h		
Iso flow	ml/h		
Hal flow	ml/h		
Sev flow	ml/h		
O ₂ Flow	L/min	O ₂ flow	Yes
N ₂ O Flow	L/min	N ₂ O flow	Yes
Air Flow	L/min	Air flow	Yes
I:E	\	Inspiratory time:Expiratory time ratio	No
FRC	ml	Fractional residual capacity	No
FiO ₂ %	%	Fractional concentration of O ₂ in inspired gas	Yes
EtO ₂ %	%	End-tidal O ₂	Yes

Monitor output: parameters from GE Aisys/Aisys CS2/Avance/Carestation 650/620/Avance CS2 anesthesia machine			
Labels	Units	Description	Trend, record, print
ΔO_2 %	%	Difference between inspiratory and expiratory O_2	No
FiCO2%	%	Fraction of inspired carbon dioxide	Yes
EtCO2%	%	End-tidal carbon dioxide	Yes
FiHal	%	Inspired anesthetic agent	Yes
FiIso	%		
FiEnf	%		
FiDes	%		
FiSev	%		
EtSev	%		
EtHal	%		
EtIso	%		
EtEnf	%		
EtDes	%		
Setting Parameters			
TV	ml	Tidal volume	No
f	bpm	Breath rate	No
I:E	\	Inspiratory time:Expiratory time ratio	No
TIP:TI	%	Percentage of inspiratory plateau time in inspiratory time	No
PEEP	cmH2O, hPa, mbar	Positive end-expiratory pressure	No
Plimit	cmH2O, hPa, mbar	Pressure limit level	No
Pinsp	cmH2O, hPa, mbar	Pressure control level of inspiration	No
ΔP_{supp}	cmH2O, hPa, mbar	Pressure support level	No
Pmax	cmH2O, hPa, mbar	Maximal breathing pressure	No
IBW	kg	Ideal body weight	No

Monitor output: parameters from GE Aisys/Aisys CS2/Avance/Carestation 650/620/Avance CS2 anesthesia machine			
Labels	Units	Description	Trend, record, print
BSA	m2	Body surface area	No
Rise Time%	%	rise time%	No
F-Trig	L/min	Inspiratory trigger level (flow trigger)	No
P-Trig	cmH2O, hPa, mbar	Inspiratory trigger level (pressure trigger)	No
T _{insp}	sec	Time of inspiration ⁸	No
T _{pause} %	%	Pause Time%	No

3.9.2 Output Signals - Alarms

Monitor output: alarms from GE Aisys/Aisys CS2/Avance/Carestation 650/620/Avance CS2 anesthesia machine		
Mindray Patient Monitor		Aisys/Aisys CS2/Avance/Carestation 650/620/Avance CS2 Alarm
Priority	Label	Label
Physiological alarms		
High	Paw High	High Paw
High	Paw Low	Low Paw
High	High Paw Sustained	High Paw Sustained
High	Volume Apnea > 2 min	Volume Apnea > 2 min
High	EtO ₂ Low	Low etO ₂
High	EtO ₂ High	High etO ₂
High	FiO ₂ Low	Low FiO ₂
High	FiO ₂ High	High FiO ₂
High	CO ₂ Apnea	CO ₂ Apnea
Medium	Sub-Atmospheric Paw	Sub-Atmospheric Paw
Medium	MV Low	Low VE

Monitor output: alarms from GE Aisys/Aisys CS2/Avance/Carestation 650/620/Avance CS2 anesthesia machine		
Mindray Patient Monitor		Aisys/Aisys CS2/Avance/Carestation 650/620/Avance CS2 Alarm
Priority	Label	Label
Medium	MV High	High VE
Medium	TVe Low	Low Vte
Medium	TVe High	High Vte
Medium	Volume Apnea	Volume Apnea
Medium	RR High	High RR
Medium	RR Low	Low RR
Medium	EtCO ₂ Low	Low etCO ₂
Medium	EtCO ₂ High	High etCO ₂
Medium	FiCO ₂ High	High FiCO ₂
Medium	EtAA Low	Low etAA
Medium	EtAA High	High etAA
Medium	FiAA Low	Low FiAA
Medium	FiAA High	High FiAA
Low	PRESSURE LIM	Plimit Reached
Low	Pressure Limiting	Sustained Paw
Technical alarms		
High	No Fresh Gas	No Fresh Gas Flow
High	O ₂ Supply Failure	No O ₂ Pressure
High	Circuit Occluded	Circuit Occluded

Monitor output: alarms from GE Aisys/Aisys CS2/Avance/Carestation 650/620/Avance CS2 anesthesia machine		
Mindray Patient Monitor		Aisys/Aisys CS2/Avance/Carestation 650/620/Avance CS2 Alarm
Priority	Label	Label
High	High Technical alarms	<p>If the monitor shows the alarm [High Technical alarms], the external device may have the following alarms:</p> <ul style="list-style-type: none"> Pmax Reached Pinspired Not Achieved Other Priority Alarms (for high priority alarms not assigned a unique bit) No VO₂ High FiN₂O Low Drive Gas Pressure Low Battery Charge Low Battery (No AC) Control Settings Failure
High	High Technical alarms	<p>If the monitor shows the alarm [High Technical alarms], the external device may have the following alarms:</p> <ul style="list-style-type: none"> Therapy Computer Failure Monitoring Computer Failure Display Computer Failure System Error Mixer Failure Mixer Leak Mixer Control Failure Vent Failure Mechanical Ventilation Disabled Patient Detected (while in standby) High O₂ Supply Pressure High Air Supply Pressure
Medium	Patient Circuit Leak	Patient Circuit Leak

Monitor output: alarms from GE Aisys/Aisys CS2/Avance/Carestation 650/620/Avance CS2 anesthesia machine		
Mindray Patient Monitor		Aisys/Aisys CS2/Avance/Carestation 650/620/Avance CS2 Alarm
Priority	Label	Label
Medium	AG Module abnormal	<p>If the monitor shows the alarm [AG Module abnormal], the external device may have the following alarms:</p> <ul style="list-style-type: none"> MGAS ANE_WARMING_UP (5-minute warming up) MGAS WARMING_UP (2-minute warming up) No VO₂ FiO₂ > 85% Alternate O₂ ON Air Only Mode MGAS Failure Module Not Compatible Vaporizer Cassette Failure AA Delivery Disabled MGAS Outlet Occluded MGAS Filter Blocked MGAS Sample Line Blocked MGAS No Sample Line
Medium	AG Module abnormal	<p>If the monitor shows the alarm [AG Module abnormal], the external device may have the following alarms:</p> <ul style="list-style-type: none"> MGAS Replace Water Trap Vaporizer Cassette Agent Level Low No Vaporizer Cassette Vaporizer Failure Vaporizer Leak AA Control Failure

Monitor output: alarms from GE Aisys/Aisys CS2/Avance/Carestation 650/620/Avance CS2 anesthesia machine		
Mindray Patient Monitor		Aisys/Aisys CS2/Avance/Carestation 650/620/Avance CS2 Alarm
Priority	Label	Label
Medium	Medium Technical alarms	<p>If the monitor shows the alarm [Medium Technical alarms], the external device may have the following alarms:</p> <ul style="list-style-type: none"> High Circuit O₂ Low Circuit O₂ No O₂ Cell Sensor No Pressure Cntrl/PEEP Inspiration Stopped Inspiratory Reverse Flow Expiratory Reverse Flow Check Flow Sensors No Air Pressure No VO₂ No VO₂, Artifact No VO₂, High Bypass Flow No Battery Battery Failure Battery Charger Failure Non Circle Circuit Selected Expiratory Flow Sensed with Non Circle Circuit Verify Low VE Limit Fan Failure Heater Failure Power Supply Failure Display Failure Breathing System Failure

Monitor output: alarms from GE Aisys/Aisys CS2/Avance/Carestation 650/620/Avance CS2 anesthesia machine		
Mindray Patient Monitor		Aisys/Aisys CS2/Avance/Carestation 650/620/Avance CS2 Alarm
Priority	Label	Label
Medium	Medium Technical alarms	If the monitor shows the alarm [Medium Technical alarms], the external device may have the following alarms: Sensor Interface Board Failure ACGO Failure SCGO Failure Primary Audio Failure Backup Audio Failure Nebulizer Failure No Nebulizer
Low	Battery in Use	Running On Battery (No AC)
Low	Low Technical alarms	If the monitor shows the alarm [Low Technical alarms], the external device may have the following alarms: ASR on Replace O ₂ Cell O ₂ Cell Calibration Error PEEP Not Achieved Vt Not Achieved No Inspiratory Flow Sensor No Expiratory Flow Sensor Insp Vt/Vte Mismatch (VTE > Insp VT) Vdel Mismatch (System Leak) Bellows Empty No N ₂ O Pressure Memory (EEPROM) Failure Flow Sensor Cal Data Corrupt Service Calibrations Due.

3.9.3 Output Signals - Waveforms (For BeneVision N series Monitors)

Label	Units
Paw	cmH2O, mbar, hpa
Flow	L/min
Vol	mL
CO2	mmHg, kPa, %
O2	%
AA	%
Hal	%
Des	%
Sev	%
Enf	%
Iso	%

3.9.4 Output Signals – Respiratory Loops (For BeneVision N series Monitors)

Label	Units
PV Loop	cmH2O/ml, hPa/ml, mbar/ml
FV Loop	L/min/ml
PF Loop	cmH2O/L/min, hPa/L/min, mbar/L/min

3.10 HuL Leon

3.10.1 Output Signals - Parameters

Monitor output: parameters from Hul Leon anesthesia machine			
Labels	Units	Description	Trend, record, print
Monitoring Parameters			
O ₂ %	%	Oxygen concentration	Yes
PEEP	cmH ₂ O, hPa, mbar	Positive end-expiratory pressure	Yes
Ppeak	cmH ₂ O, hPa, mbar	Peak pressure	Yes
Pplat	cmH ₂ O, hPa, mbar	Plateau pressure	Yes
Pmean	cmH ₂ O, hPa, mbar	Mean pressure	Yes
TVe	ml	Expiratory tidal volume	Yes
TVi	ml	Inspired tidal volume	Yes
MV	L/min	Minute volume	Yes
ftotal	bpm	Total respiratory rate	Yes
fspn	bpm	Spontaneous respiratory rate	Yes
Compl	ml/cmH ₂ O,ml/ hPa,ml/mbar	Compliance	Yes
RAW	cmH ₂ O/L/s,hPa/L/ s,mbar/L/s	Airway resistance	Yes
EtCO ₂	%,kPa,mmHg	End-tidal carbon dioxide	Yes
FiCO ₂	%,kPa,mmHg	Fraction of inspired carbon dioxide	Yes
FiO ₂	%,kPa,mmHg	Fractional concentration of O ₂ in inspired gas	Yes
EtO ₂	%,kPa,mmHg	End-tidal O ₂	Yes
FiN ₂ O	%	Inspired anesthetic agent	Yes
FiIso	%		
FiDes	%		
FiEnf	%		
FiSev	%		
FiHal	%		

Monitor output: parameters from Hul Leon anesthesia machine			
Labels	Units	Description	Trend, record, print
EtN ₂ O	%	End-tidal anesthetic agent	Yes
EtEnf	%		
EtDes	%		
EtIso	%		
EtSev	%		
EtHal	%		
MAC	\	Minimum alveolar concentration	Yes
FiO ₂ %	%	Fractional concentration of O ₂ in inspired gas	Yes
EtO ₂ %	%	End-tidal O ₂	Yes
EtCO ₂ %	%	End-tidal carbon dioxide	Yes
FiCO ₂ %	%	Fraction of inspired carbon dioxide	Yes
FiAA	%	Inspired anesthetic agent	Yes
FiAA_2nd	%	2nd Insp. Agent	Yes
EtAA	%	End-tidal anesthetic agent	Yes
EtAA_2nd	%	2nd Exp. Agent	Yes
Setting Parameters			
TV	ml	Tidal volume	No
TVi	ml	Inspired tidal volume	No
f	bpm	Breath rate	No
I:E	\	Inspiratory time:Expiratory time ratio	No
Insp Flow	L/min	Inspiration flow	No
T _{insp}	sec	Time of inspiration	No
P _{insp}	cmH ₂ O, hPa, mbar	Pressure control level of inspiration	No
F-Trig	L/min	Inspiratory trigger level (flow trigger)	No

Monitor output: parameters from Hul Leon anesthesia machine			
Labels	Units	Description	Trend, record, print
Pmax	cmH2O, hPa, mbar	Maximal breathing pressure	No
Tpause	%	Pause Time%	No
PEEP	cmH2O, hPa, mbar	Positive end-expiratory pressure	No

3.10.2 Output Signals - Alarms

Monitor output: alarms from HuL Leon anesthesia machine		
Mindray Patient Monitor		HuL Leon Alarm
Priority	Label	Label
Physiological alarms		
High	Apnea	Apnea: Backup Breath was triggered /Apnea
High	CO ₂ Apnea	Apnea CO ₂
High	High Paw Sustained	Patient pressure continuously too high
High	Paw High	Ppeak high
Medium	EtCO ₂ High	Expiratory CO ₂ high
Medium	EtCO ₂ Low	Expiratory CO ₂ low
Medium	FiEnf High	ENF insp. too high
Medium	FiCO ₂ High	Inspiratory CO ₂ high
Medium	FiDes High	DES insp. too high
Medium	FiDes Low	DES insp. too low
Medium	FiEnf High	ENF insp. too low
Medium	FiHal High	HAL insp. too high
Medium	FiHal Low	HAL insp. too low
Medium	Filso High	ISO insp. too high
Medium	Filso Low	ISO insp. too low
Medium	FiO ₂ High	Inspiratory O ₂ high
Medium	FiO ₂ Low	Inspiratory O ₂ low
Medium	FiSev High	SEVO insp. too high

Monitor output: alarms from HuL Leon anesthesia machine		
Mindray Patient Monitor		HuL Leon Alarm
Priority	Label	Label
Medium	FiSev Low	SEVO insp. too low
Medium	MV High	MV high
Medium	MV Low	MV low
Medium	PRESS EXP High	No release of pressure during expiration
Medium	RR Low	FreqCO2 low
Medium	RR High	FreqCO2 high
Medium	TVe Low	Vte low
Low	PRESSURE LIM	PMax setting reached too early
Technical alarms		
High	Circuit Occluded	Gasmeasurement Occlusion (Artema AION)
High	Drive Gas Pressure Low	1. No driving gas. Mechanical ventilation stopped. Only Man/Spont possible. 2. Freshgas shortage
High	No Fresh Gas	O2 and Air supply failed. Dosing fresh gas stopped
High	O ₂ Supply Failure	1. O2 cell fresh gas failed. Please change. Fresh gas is 100% O2 2.Deviation O2 Concentration fresh gas. Fresh gas is 100% O2 3.O2 cell of fresh gas not calibrated. Fresh gas is 100% O2
High	VENT DISC	Patient module unlocked. Ventilation stopped /Disconnection
High	High Technical Alarm	If the monitor shows the alarm [High Technical alarms], the external device may have the following alarms: Battery empty. Mechanical ventilation stopped. Only Man/Spont possib Battery empty. Supply voltage Low Calib. needed: Remove O ₂ -Cell short-time. Checksum Error

Monitor output: alarms from HuL Leon anesthesia machine		
Mindray Patient Monitor		HuL Leon Alarm
Priority	Label	Label
High	High Technical Alarm	<p>If the monitor shows the alarm [High Technical alarms], the external device may have the following alarms:</p> <p>Checksum Fail PIC Conductor</p> <p>CFB Timeout</p> <p>Checksum Fail PIC Monitor</p> <p>CO₂ absorber removed. Circle system short-circuited</p> <p>Communication Fail CFB</p> <p>Communication Fail Conductor PIC</p> <p>Communication Fail Power PIC</p> <p>Communication Fail Monitor PIC (Busy Timeout)</p> <p>Communication Fail Monitor PIC (Read Timeout)</p> <p>Communication Fail Monitor PIC (Write Timeout)</p> <p>Controllerboard EEPROM checksum failed</p> <p>Controllerboard EEPROM not write protected</p> <p>Driving gas blender failed.</p> <p>Encoder without function</p> <p>Ext. fresh gas outlet active</p> <p>Expiratory flow measurement failed. No expiratory volume measurement.</p> <p>Failsafe</p> <p>Failure O₂ Measurement. Please calibrate O₂ Cell</p> <p>FI_O₂ Cell badly calibrated</p> <p>Flowsensor contaminated. No measurement of expiratory flow.</p> <p>Flowsensor contaminated. No measurement of inspiratory flow.</p> <p>Flowsensor disconnected. No volume measurement.</p> <p>Fresh gas blender failed (flow High). Turn on emergency dosing</p> <p>Fresh gas blender failed (flow Low). Turn on emergency dosing!</p>

Monitor output: alarms from HuL Leon anesthesia machine		
Mindray Patient Monitor		HuL Leon Alarm
Priority	Label	Label
High	High Technical Alarm	<p>If the monitor shows the alarm [High Technical alarms], the external device may have the following alarms:</p> <p>Fresh gas blender failed (N₂O). Turn on emergency dosing!</p> <p>Fresh gas blender failed (no flow measurement) Turn on emergency dosing!</p> <p>Fresh gas blender failed (O₂). Turn on emergency dosing!</p> <p>Fresh gas blender failed (valves). Fresh gas is 100% O₂</p> <p>Gas Measurement failed (Artema AION)</p> <p>Systemtest skipped too many times</p> <p>Technical Failure CFB (see error log)</p> <p>Technical Failure NetDCU (see error log)</p> <p>Technical failure. Only Man/Spont possible</p> <p>Versions not compatible</p> <p>Zero flow. Flow sensor not calibrated</p>
Medium	Patient Circuit Leak	Leak high
Medium	Medium Technical Alarm	<p>If the monitor shows the alarm [Medium Technical alarms], the external device may have the following alarms:</p> <p>Battery almost empty</p> <p>Battery Check/Charge Fail</p> <p>Batteries deep discharged. Please calibrate</p> <p>Battery Fail</p> <p>Battery falsely connected or damaged</p> <p>Change Water Trap (Artema AION)</p> <p>Gas Measurement unreliable (Artema AION)</p> <p>Set pressure not reachable</p> <p>Set volume not reachable</p> <p>Broken loudspeaker. Audible alarming not possible</p> <p>Broken microphone. No checking of audible alarming</p>
Low	Battery in Use	Device running on batteries

Monitor output: alarms from HuL Leon anesthesia machine		
Mindray Patient Monitor		HuL Leon Alarm
Priority	Label	Label
Low	NO AIR	Air supply failed, Fresh gas with 100% O ₂ /Air supply failed
Low	NO O ₂ SUPPLY	O ₂ supply failed. Dosing fresh gas with air (=21% O ₂). /O ₂ supply failed /Piped O ₂ supply too low
Low	O ₂ Sensor Unconnected	FiO ₂ cell failed. Please change.
Low	Low Technical Alarm	<p>If the monitor shows the alarm [Low Technical alarms], the external device may have the following alarms:</p> <p>Air and N₂O supply failed, Fresh gas with 100% O₂</p> <p>Air supply failed. Driving gas is O₂</p> <p>Air supply pressure High</p> <p>Check external O₂ measurement</p> <p>CO₂ absorber removed. Circle system short-circuited</p> <p>Emergency dosing active</p> <p>Emergency dosing still active. Please turn off emergency dosing</p> <p>Exhalation Condition not reached</p> <p>Ext. fresh gas outlet active</p> <p>Failure during communication with VueLink</p> <p>Fan Fail</p> <p>HL7 server not available</p> <p>MemoryStick Fail</p> <p>No Primary Agent detected</p> <p>N₂O supply failed</p> <p>N₂O supply failed, Fresh gas with 100% O₂</p> <p>N₂O supply from reserve</p> <p>O₂ ZGA supply failed. Driving gas is air</p> <p>Patient module open</p> <p>Piped N₂O supply pressure High</p> <p>Piped N₂O supply Low</p> <p>Piped O₂ supply pressure High</p> <p>VueLink not connected</p>

3.11 HuL Leon Plus

3.11.1 Output Signals - Parameters

Monitor output: parameters from Hul Leon Plus anesthesia machine			
Labels	Units	Description	Trend, record, print
Monitoring Parameters			
O ₂ %	%	Oxygen concentration	Yes
PEEP	cmH ₂ O, hPa, mbar	Positive end-expiratory pressure	Yes
P _{peak}	cmH ₂ O, hPa, mbar	Peak pressure	Yes
P _{plat}	cmH ₂ O, hPa, mbar	Plateau pressure	Yes
P _{mean}	cmH ₂ O, hPa, mbar	Mean pressure	Yes
T _{Ve}	ml	Expiratory tidal volume	Yes
T _{Vi}	ml	Inspired tidal volume	Yes
MV	L/min	Minute volume	Yes
f _{total}	bpm	Total respiratory rate	Yes
f _{spn}	bpm	Spontaneous respiratory rate	Yes
Compl	ml/cmH ₂ O,ml/hPa,ml/mbar	Compliance	Yes
RAW	cmH ₂ O/L/s,hPa/L/s,mbar/L/s	Airway resistance	Yes
FiCO ₂	%.kPa,mmHg	Fraction of inspired carbon dioxide	Yes
EtCO ₂	%.kPa,mmHg	End-tidal carbon dioxide	Yes
FiO ₂	%.kPa,mmHg	Fractional concentration of O ₂ in inspired gas	Yes
EtO ₂	%.kPa,mmHg	End-tidal O ₂	Yes
FiN ₂ O	%	Inspired anesthetic agent	Yes
FiIso	%		
FiDes	%		
FiEnf	%		
FiSev	%		
FiHal	%		

Monitor output: parameters from Hul Leon Plus anesthesia machine			
Labels	Units	Description	Trend, record, print
EtN ₂ O	%	End-tidal anesthetic agent	Yes
EtEnf	%		
EtDes	%		
EtIso	%		
EtSev	%		
EtHal	%		
MAC	\	Minimum alveolar concentration	Yes
FiO ₂ %	%	Fractional concentration of O ₂ in inspired gas	Yes
EtO ₂ %	%	End-tidal O ₂	Yes
FiCO ₂ %	%	Fraction of inspired carbon dioxide	Yes
EtCO ₂ %	%	End-tidal carbon dioxide	Yes
FiAA	%	Inspired anesthetic agent	Yes
FiAA_2nd	%	2nd Insp. Agent	Yes
EtAA	%	End-tidal anesthetic agent	Yes
EtAA_2nd	%	2nd Exp. Agent	Yes
Setting Parameters			
PEEP	cmH ₂ O, hPa, mbar	Positive end-expiratory pressure	No
TV	ml	Tidal volume	No
TVi	ml	Inspired tidal volume	No
f	bpm	Breath rate	No
Insp Flow	L/min	Inspiration flow	No
I:E	\	Inspiratory time:Expiratory time ratio	No
T _{insp}	sec	Time of inspiration	No
P _{insp}	cmH ₂ O, hPa, mbar	Pressure control level of inspiration	No
P _{max}	cmH ₂ O, hPa, mbar	Maximal breathing pressure	No

Monitor output: parameters from Hul Leon Plus anesthesia machine			
Labels	Units	Description	Trend, record, print
F-Trig	L/min	Inspiratory trigger level (flow trigger)	No
Tpause	%	Pause Time%	No

3.11.2 Output Signals - Alarms

Monitor output: alarms from HuL Leon Plus anesthesia machine		
Mindray Patient Monitor		HuL Leon Plus Alarm
Priority	Label	Label
Physiological alarms		
High	Apnea	Apnea: Backup Breath was triggered /Apnea
High	CO ₂ Apnea	Apnea CO ₂
High	FiO ₂ Low	Inspiratory O ₂ low
High	Paw High	Ppeak high
High	High Paw Sustained	Patient pressure continuously too high
Medium	EtCO ₂ High	Expiratory CO ₂ high
Medium	EtCO ₂ Low	Expiratory CO ₂ low
Medium	FiCO ₂ High	Inspiratory CO ₂ high
Medium	FiDes Low	DES insp. too low
Medium	FiDes High	DES insp. too high
Medium	FiEnf Low	ENF insp. too low
Medium	FiEnf High	ENF insp. too high
Medium	FiHal High	HAL insp. too high
Medium	FiHal Low	HAL insp. too low
Medium	Filso High	ISO insp. too high
Medium	Filso Low	ISO insp. too low
Medium	FiO ₂ High	Inspiratory O ₂ high
Medium	FiSev High	SEVO insp. too high

Monitor output: alarms from HuL Leon Plus anesthesia machine		
Mindray Patient Monitor		HuL Leon Plus Alarm
Priority	Label	Label
Medium	FiSev Low	SEVO insp. too low
Medium	MV High	MV high
Medium	MV Low	MV low
Medium	PRESS EXP High	No release of pressure during expiration
Medium	RR Low	FreqCO2 low
Medium	RR High	FreqCO2 high
Medium	TVe Low	Vte low
Low	PRESSURE LIM	PMax setting reached too early
Technical alarms		
High	Circuit Occluded	Gasmeasurement Occlusion (Artema AION)
High	Drive Gas Pressure Low	No driving gas. Mechanical ventilation stopped. Only Man/Spont possible
High	No Fresh Gas	O2 and Air supply failed. Dosing fresh gas stopped.
High	O ₂ Supply Failure	O2 cell fresh gas failed. Please change. Fresh gas is 100% O2
High	VENT DISC	Patient module unlocked. Ventilation stopped. Disconnection
High	High Technical Alarm	<p>If the monitor shows the alarm [High Technical alarms], the external device may have the following alarms:</p> <ul style="list-style-type: none"> Battery empty. Mechanical ventilation stopped. Only Man/Spont possible Battery empty. Supply voltage too low Calib. needed: Remove O2-Cell short-time. CFB Timeout Checksum Error Checksum Fail PIC Conductor Checksum Fail PIC Monitor Communication Fail CFB Communication Fail Conductor PIC

Monitor output: alarms from HuL Leon Plus anesthesia machine		
Mindray Patient Monitor		HuL Leon Plus Alarm
Priority	Label	Label
High	High Technical Alarm	<p>If the monitor shows the alarm [High Technical alarms], the external device may have the following alarms:</p> <p>Communication Fail Monitor PIC (Busy Timeout)</p> <p>Communication Fail Monitor PIC (Read Timeout)</p> <p>Communication Fail Monitor PIC (Write Timeout)</p> <p>Communication Fail Power PIC</p> <p>Controllerboard EEPROM checksum failed</p> <p>Controllerboard EEPROM not write protected</p> <p>CO2 absorber removed. Circle system shortcircuited</p> <p>Driving gas blender failed.</p> <p>Encoder without function</p> <p>Ext. fresh gas outlet active</p> <p>Expiratory flow measurement failed. No expiratory volume measurement.</p> <p>Failsafe</p> <p>Failure O2 Measurement. Please calibrate O2 Cell</p> <p>FiO2 Cell badly calibrated</p> <p>Flowsensor contaminated. No measurement of expiratory flow.</p> <p>Flowsensor contaminated. No measurement of inspiratory flow.</p> <p>Flowsensor disconnected. No volume measurement.</p> <p>Fresh gas blender failed (flow too high). Turn on emergency dosing</p> <p>Fresh gas blender failed (flow too low). Turn on emergency dosing!</p> <p>Fresh gas blender failed (N2O). Turn on emergency dosing!</p> <p>Fresh gas blender failed (no flow measurement) Turn on emergency dosing!</p> <p>Fresh gas blender failed (O2). Turn on emergency dosing!</p>

Monitor output: alarms from HuL Leon Plus anesthesia machine		
Mindray Patient Monitor		HuL Leon Plus Alarm
Priority	Label	Label
High	High Technical Alarm	<p>If the monitor shows the alarm [High Technical alarms], the external device may have the following alarms:</p> <p>Fresh gas blender failed (valves). Fresh gas is 100% O2</p> <p>Gas Measurement failed (Artema AION)</p> <p>Inspiratory flow measurement failed. No inspiratory volume measurement.</p> <p>Mains Fail Conductor PIC</p> <p>Mains Fail Monitor PIC</p> <p>No water trap</p> <p>Read settings differ from written setting</p> <p>Security relay broken</p> <p>Sensor fail O2 measurement fresh gas.</p> <p>Switched to 100% O2 fresh gas flow</p> <p>Sensor Fail Patient Pressure</p> <p>System Fail Monitor Artema AION</p> <p>Systemtest skipped too many times</p> <p>Technical Failure CFB (see error log)</p> <p>Technical Failure NetDCU (see error log)</p> <p>Technical failure. Only Man/Spont possible</p> <p>Versions not compatible</p> <p>Zero flow. Flow sensor not calibrated</p>
Medium	Patient Circuit Leak	
Medium	Medium Technical Alarm	<p>If the monitor shows the alarm [Medium Technical alarms], the external device may have the following alarms:</p> <p>Battery almost empty</p> <p>Battery Check/Charge Fail</p> <p>Batteries deep discharged. Please calibrate</p> <p>Battery Fail</p> <p>Battery falsely connected or damaged</p> <p>Broken loudspeaker. Audible alarming not possible</p> <p>Change Water Trap (Artema AION)</p> <p>Gas Measurement unreliable (Artema AION)</p>

Monitor output: alarms from HuL Leon Plus anesthesia machine		
Mindray Patient Monitor		HuL Leon Plus Alarm
Priority	Label	Label
Medium	Medium Technical Alarm	If the monitor shows the alarm [Medium Technical alarms], the external device may have the following alarms: Set pressure not reachable Set volume not reachable Broken microphone. No checking of audible alarming
Low	Battery in Use	
Low	NO AIR	
Low	NO O2 SUPPLY	
Low	O2 Sensor Unconnected	
Low	Low Technical Alarm	If the monitor shows the alarm [Low Technical alarms], the external device may have the following alarms: Air and N2O supply failed, Fresh gas with 100% O2 Air supply failed. Driving gas is O2 Air supply pressure too high Check external O2 measurement CO2 absorber removed. Circle system shortcircuited Emergency dosing active Emergency dosing still active. Please turn off emergency dosing Exhalation Condition not reached Ext. fresh gas outlet active Failure during communication with VueLink Fan Fail HL7 server not available MemoryStick Fail N2O supply failed N2O supply failed, Fresh gas with 100% O2 N2O supply from reserve No Primary Agent detected Patient module open

Monitor output: alarms from HuL Leon Plus anesthesia machine		
Mindray Patient Monitor		HuL Leon Plus Alarm
Priority	Label	Label
Low	Low Technical Alarm	If the monitor shows the alarm [Low Technical alarms], the external device may have the following alarms: Piped N2O supply pressure too high Piped N2O supply too low Piped O2 supply pressure too high O2 ZGA supply failed. Driving gas is air VueLink not connected

3.12 MAQUET FLOW-i/c/e

3.12.1 Output Signals - Parameters

Monitor output: parameters from MAQUET FLOW-i anesthesia machine			
Labels	Units	Description	Trend, record, print
Monitoring Parameters			
PEEP	cmH2O, hPa, mbar	Positive end-expiratory pressure	Yes
Ppeak	cmH2O, hPa, mbar	Peak pressure	Yes
Pplat	cmH2O, hPa, mbar	Plateau pressure	Yes
Pmean	cmH2O, hPa, mbar	Mean pressure	Yes
TVi	ml	Inspired tidal volume	Yes
MVe	L/min	Expiratory minute volume	Yes
MVi	L/min	Inspiratory minute volume	Yes
ftotal	bpm	Total respiratory rate	Yes
I:E	\	Inspiratory time:Expiratory time ratio	No
Exp Flow	L/min	Expiratory flow	No
Compl	ml/cmH2O,ml/hPa,ml/mbar	Compliance	Yes
EtCO ₂	%,kPa,mmHg	End-tidal carbon dioxide	Yes

Monitor output: parameters from MAQUET FLOW-i anesthesia machine			
Labels	Units	Description	Trend, record, print
FiCO ₂	%,kPa,mmHg	Fraction of inspired carbon dioxide	Yes
FiO ₂	%,kPa,mmHg	Fractional concentration of O ₂ in inspired gas	Yes
EtO ₂	%,kPa,mmHg	End-tidal O ₂	Yes
FiN ₂ O	%	Fraction of inspired nitrous oxide	Yes
EtN ₂ O	%	End-tidal N ₂ O	Yes
FiAA	%	Inspired anesthetic agent	Yes
EtAA	%	End-tidal anesthetic agent	Yes
FiAA 2nd	%	2nd Insp. Agent	Yes
EtAA 2nd	%	2nd Exp. Agent	Yes
MAC	\	Minimum alveolar concentration	Yes
PO ₂	kPa	Oxygen supply pressure	No
PN ₂ O	kPa	N ₂ O supply pressure	No
Pair	kPa	Air supply pressure	No
Ti/Ttot	\	Duty cycle or ratio of inspiration time to total breathing cycle time (only during spontaneous breathing)	No
FiO ₂ %	%	Fractional concentration of O ₂ in inspired gas	Yes
EtO ₂ %	%	End-tidal O ₂	Yes
FiCO ₂ %	%	Fraction of inspired carbon dioxide	Yes
EtCO ₂ %	%	End-tidal carbon dioxide	Yes
TVe	ml	Expiratory tidal volume	Yes
Setting Parameters			
TV	ml	Tidal volume	No
MV	L/min	Minute volume	No
f	bpm	Breath rate	No

Monitor output: parameters from MAQUET FLOW-i anesthesia machine			
Labels	Units	Description	Trend, record, print
I:E	\	Inspiratory time:Expiratory time ratio	No
Tslope	sec	Time for the pressure to rise to target pressure	No
Tinsp	sec	Time of inspiration	No
PC above PEEP	cmH2O, hPa, mbar	PC above PEEP	No
PS above PEEP	cmH2O, hPa, mbar	PS above PEEP	No
P-Trig	cmH2O, hPa, mbar	Inspiratory trigger level(pressure trigger)	No
F-Trig	\	Inspiratory trigger level (flow trigger)	No
Insp Flow	L/min	Inspiratory flow	No
FG	ml/min	Fresh gas flow	No
PEEP	cmH2O, hPa, mbar	Positive end-expiratory pressure	No
Rise Time%	%	rise time%	No
Tpause	%	Pause Time%	No
Tinsp%	%	Time of inspiration	No
Tpause	sec	Pause Time	No

3.12.2 Output Signals - Alarms

Monitor output: alarms from MAQUET FLOW-i anesthesia machine		
Mindray Patient Monitor		MAQUET FLOW-i Alarm
Priority	Label	Label
Physiological alarms		
High	Apnea	Apnea
High	Paw High	Paw High
High	High Paw Sustained	High continuous pressure
High	EtO2 High	EtO2 High
High	EtO2 Low	EtO2 Low
High	FiO2 Low	FiO2 Low
Medium	MV High	MV too high
Medium	MV Low	MV too Low
Medium	PEEP High	PEEP High
Medium	PEEP Low	PEEP Low
Medium	EtCO ₂ High	EtCO2 High
Medium	EtCO ₂ Low	EtCO2 Low
Medium	FiCO ₂ High	FiCO2 High
Medium	FiN ₂ O High	FiN2O High
Medium	EtIso High	EtIso High
Medium	EtIso Low	EtIso Low
Medium	Filso High	Filso High
Medium	Filso Low	Filso Low
Medium	EtSev High	EtSev High
Medium	EtSev Low	EtSev Low
Medium	FiSev High	FiSev High
Medium	FiSev Low	FiSev Low
Medium	EtDes High	EtDes High
Medium	EtDes Low	EtDes Low
Medium	FiDes High	FiDes High

Monitor output: alarms from MAQUET FLOW-i anesthesia machine		
Mindray Patient Monitor		MAQUET FLOW-i Alarm
Priority	Label	Label
Medium	FiDes Low	FiDes Low
Medium	FiO ₂ High	FiO ₂ High
Low	RR High	frequency high
Low	RR Low	frequency low
Technical alarms		
High	Circuit Occluded	Gas sampling tube Occlusion
High	High Technical alarms	If the monitor shows the alarm [High Technical alarms], the external device may have the following alarms: Mixture of Anesthesia agents Gas Supply Cross contamination of anesthetic Agents Vaporizer liquid level battery alarm patient Cassette remove patient Cassette exchange check tubing alarm
Medium	Medium Technical alarms	If the monitor shows the alarm [Medium Technical alarms], the external device may have the following alarms: Gas Analyzer water trap Gas Analyzer water trap missing internal communication failure High continuous APL Pressure alarm Leakage alarm
Low	Battery in Use	Battery operation

3.12.3 Output Signals - Waveforms (For BeneVision N series Monitors)

Label	Units
Paw	cmH2O, mbar, hpa
Flow	L/min
Vol	mL
CO2	mmHg, kPa,%
O2	%
Des	%
Sev	%
Iso	%

3.12.4 Output Signals – Respiratory Loops (For BeneVision N series Monitors)

Label	Units
PV Loop	cmH2O/ml, hPa/ml, mbar/ml
FV Loop	L/min/ml
PF Loop	cmH2O/L/min, hPa/L/min, mbar/L/min

3.13 Mindray A9/A8/A7/A5/A4/A3/WATO EX-65/55/35/25/60/50/30/20/65 Pro/55 Pro

NOTE

- Only the Benevision N Series monitor supports integration with the Mindray A9/A8/A4 anesthesia machine.

3.13.1 Output Signals - Parameters

Monitor output: parameters from Mindray A9/A8/A7/A5/A4/A3/WATO EX-65/55/35/25/60/50/30/20/65 Pro/55 Pro anesthesia machine			
Labels	Units	Description	Trend, record, print
Monitoring Parameters			
I:E	/	Inspiratory time: Expiratory time ratio	No
PEEP	cmH2O, hPa, mbar	Positive end-expiratory pressure	Yes
Ppeak	cmH2O, hPa, mbar	Peak pressure	Yes
Pplat	cmH2O, hPa, mbar	Plateau pressure	Yes
Pmean	cmH2O, hPa, mbar	Mean pressure	Yes
MVe	L/min	Expiratory minute volume	Yes
TVe	ml	Expiratory tidal volume	Yes
RAW	cmH2O/L/s, hPa/L/s, mbar/L/s	Airway resistance	Yes
Compl	ml/cmH2O, ml/hPa, ml/mbar	Compliance	Yes
N ₂ O Flow	L/min	N ₂ O flow	Yes
Air Flow	L/min	Air flow	Yes
O ₂ Flow	L/min	O ₂ flow	Yes
EtCO ₂	%, kPa, mmHg	End-tidal carbon dioxide	Yes
FiCO ₂	%, kPa, mmHg	Fraction of inspired carbon dioxide	Yes
FiN ₂ O	%	Fraction of inspired nitrous oxide	Yes
EtN ₂ O	%	End-tidal N ₂ O	Yes

Monitor output: parameters from Mindray A9/A8/A7/A5/A4/A3/WATO EX-65/55/35/25/60/50/30/20/65 Pro/55 Pro anesthesia machine

Labels	Units	Description	Trend, record, print
EtDes	%	End-tidal anesthetic agent	Yes
EtSev	%		Yes
EtEnf	%		Yes
EtIso	%		Yes
EtHal	%		Yes
FiDes	%	Inspired anesthetic agent	Yes
FiSev	%		Yes
FiEnf	%		Yes
FiIso	%		Yes
FiHal	%		Yes
FiAA	%	Inspired anesthetic agent	Yes
EtAA	%	End-tidal anesthetic agent	Yes
MAC	\	Minimum alveolar concentration	Yes
BIS	\	Bispectral index	Yes
SQI	%	Signal quality index	Yes
SR	%	Suppression ratio	Yes
EMG	dB	Electromyograph	Yes
SEF	Hz	Spectral edge frequency	Yes
TP	dB	Total power	Yes
BC	/min	Burst count	Yes
HALLev	ml	Anesthetic agent consumption	No
ENFLev	ml		
ISOLev	ml		
DESLev	ml		
SEVLev	ml		
ftotal	bpm	Total breath rate	Yes
FiO ₂	%,kPa,mmHg	Fractional concentration of O ₂ in inspired gas	Yes

Monitor output: parameters from Mindray A9/A8/A7/A5/A4/A3/WATO EX-65/55/35/25/60/50/30/20/65 Pro/55 Pro anesthesia machine

Labels	Units	Description	Trend, record, print
EtO ₂	%,kPa,mmHg	End-tidal O ₂	
FiO ₂ %	%	Fractional concentration of O ₂ in inspired gas	Yes
EtO ₂ %	%	End-tidal O ₂	Yes
MV Leak	L/min	Difference between the inspiratory and expiratory minute volume	No
Hal Speed	ml/h	Anesthetic agent consumption speed	No
Enf Speed			No
Iso Speed			No
Sev Speed			No
Des Speed			No
TOF Ratio	%	Train-of-four ratio	Yes
TOF Count	%	Train-of-four count	Yes
DBS Ratio	%	DBS Ratio	Yes
DBS Count	\	DBS Count	Yes
ST Ratio	%	ST Ratio	Yes
ST Count	\	ST Count	Yes
PTC	\	post tetanic count	Yes
T1	%	Size of twitch 1 in %	Yes
BIS L	\	Bispectral index of left brain	Yes
BIS R	\	Bispectral index of right brain	Yes
SBIS L	\	BIS variability index of the left brain	Yes
SBIS R	\	BIS variability index of the right brain	Yes
SQI L	%	Signal quality index of left brain	Yes
SQI R	%	Signal quality index of right brain	Yes
EMG L	dB	Electromyograph of left brain	Yes

Monitor output: parameters from Mindray A9/A8/A7/A5/A4/A3/WATO EX-65/55/35/25/60/50/30/20/65 Pro/55 Pro anesthesia machine

Labels	Units	Description	Trend, record, print
EMG R	dB	Electromyograph of right brain	Yes
SEMG L	dB	EMG variability index of the left brain	Yes
SEMG R	dB	EMG variability index of the right brain	Yes
SR L	%	Suppression ratio of left brain	Yes
SR R	%	Suppression ratio of right brain	Yes
SEF L	Hz	spectral edge frequency of left brain	Yes
SEF R	Hz	spectral edge frequency of right brain	Yes
TP L	dB	Total power of left brain	Yes
TP R	dB	Total power of right brain	Yes
BC L	/min	Burst count of left brain	Yes
BC R	/min	Burst count of right brain	Yes
ASYM	%	Asymmetry	Yes
Step	/	Step	No
ΔVt	ml	ΔVt	No
Total Flow(Aux)	L/min	Total Flow(Aux)	No
O2%(Aux)	%	O2%(Aux)	No
Total Flow(HFNC)	L/min	Total Flow(HFNC)	No
O2%(HFNC)	%	O2%(HFNC)	No
Ptpl	CmH2O,hPa,mbar	Ptpl	No
PtpE	CmH2O,hPa,mbar	PtpE	No
PesI	CmH2O,hPa,mbar	PesI	No
PesE	CmH2O,hPa,mbar	PesE	No
ΔPtp	CmH2O,hPa,mbar	ΔPtp	No

Monitor output: parameters from Mindray A9/A8/A7/A5/A4/A3/WATO EX-65/55/35/25/60/50/30/20/65 Pro/55 Pro anesthesia machine

Labels	Units	Description	Trend, record, print
△Pes	CmH2O,hPa,mbar	△Pes	No
RRCO2	bpm	awRR	Yes
Setting Parameters			
F-Trig	L/min	Inspiratory trigger level (flow trigger)	No
TV	ml	Tidal volume	No
f	bpm	Breath rate	No
PEEP	cmH2O, hPa, mbar	Positive end-expiratory pressure	No
Plimit	cmH2O, hPa, mbar	Pressure limit level	No
Pinsp	cmH2O, hPa, mbar	Pressure control level of inspiration	No
△Psupp	cmH2O, hPa, mbar	Pressure support level	No
Tinsp	sec	Time of inspiration	No
Tslope	sec	Time for the pressure to rise to target pressure	No
FreqMin	bpm	Minimum breath frequency	No
TIP:TI	%	Percentage of inspiratory plateau time in inspiratory time	No
P-Trig	cmH2O, hPa, mbar	Inspiratory trigger level(pressure trigger)	No
I:E	/	Inspiratory time:Expiratory time ratio	No
Exp%	%	Inspiration termination level	No
Trigger Window	%	Trigger Window	No
fsimv	bpm	Frequency of SIMV	No
Phigh	cmH2O,hPa,mbar	Upper pressure level	No
Plow	cmH2O,hPa,mbar	Lower pressure level	No
Thigh	sec	Time for the upper pressure level	No
Tlow	sec	Time for the lower pressure level	No

Monitor output: parameters from Mindray A9/A8/A7/A5/A4/A3/WATO EX-65/55/35/25/60/50/30/20/65 Pro/55 Pro anesthesia machine

Labels	Units	Description	Trend, record, print
Δ Papnea	cmH2O,hPa,mbar	Apnea pressure	No
VtG	ml	VtG	No
Apnea Ti	sec	Apnea inspiration time	No
O2 Flow	L/min	O2 flow	No
N2O Flow	L/min	N2O flow	No
AIR Flow	L/min	Air flow	No
Apnea I:E	/	Apnea Inspiratory time: Apnea Expiratory time ratio	No
RM DeltaP	L/min	RM Δ P	No
Breaths	/	Breaths	No
Pressure Hold	cmH2O,hPa,mbar	Pressure Hold	No
Hold Time	sec	Hold Time	No
PEEP upon exit	cmH2O,hPa,mbar	PEEP upon exit	No
MinFlow	L/min	MinFlow	No
FiO2%	%	Fractional concentration of O2 in inspired gas	No
MV	L/min	Minute volume	No
Filso	%	Inspired anesthetic agent	No
FiDes	%	Inspired anesthetic agent	No
FiSev	%	Inspired anesthetic agent	No
Etlso	%	End-tidal anesthetic agent	No
EtDes	%	End-tidal anesthetic agent	No
EtSev	%	End-tidal anesthetic agent	No
PC above PEEP	cmH2O, hPa,mbar	Δ P _{insp}	No
Δ P _{insp}	cmH2O, hPa, mbar	Δ P _{insp}	No

3.13.2 Output Signals - Alarms

Monitor output: alarms from Mindray A9/A8/A7/A5/A4/A3/WATO 25/60/50/30/20/35/55/65/55/65 anesthesia machine		
Mindray Patient Monitor		Mindray A9/A8/A7/A5/A4/A3/WATO Alarm
Priority	Label	Label
Physiological alarms		
High	Apnea	Apnea Alarm
High	Volume Apnea>2min	Volume Apnea>2min
High	Paw High	Paw Too High
High	Paw Low	Paw Too Low
High	FiO ₂ Low	FiO ₂ Too Low
High	EtO ₂ High	EtO ₂ Too High
High	EtO ₂ Low	EtO ₂ Too Low
High	High Paw Sustained	Sustained Airway Pressure too High
High	CO ₂ Apnea	Apnea CO ₂
Medium	MV High	MV Too High
Medium	MV Low	MV Too Low
Medium	BIS High	BIS Too High
Medium	BIS Low	BIS Too Low
Medium	BIS L High	BIS Too High
Medium	BIS L Low	BIS Too Low
Medium	BIS R High	BIS Too High
Medium	BIS R Low	BIS Too Low
Medium	EtCO ₂ High	EtCO ₂ Too High
Medium	EtCO ₂ Low	EtCO ₂ Too Low
Medium	FiCO ₂ High	FiCO ₂ Too High
Medium	EtN ₂ O Low	EtN ₂ O Too Low
Medium	EtN ₂ O High	EtN ₂ O Too High
Medium	FiN ₂ O Low	FiN ₂ O Too Low
Medium	FiN ₂ O High	FiN ₂ O Too High

Monitor output: alarms from Mindray A9/A8/A7/A5/A4/A3/WATO 25/60/50/30/20/35/55/65/55/65 anesthesia machine		
Mindray Patient Monitor		Mindray A9/A8/A7/A5/A4/A3/WATO Alarm
Priority	Label	Label
Medium	EtHal Low	EtHal Too Low
Medium	EtHal High	EtHal Too High
Medium	FiHal Low	FiHal Too Low
Medium	FiHal High	FiHal Too High
Medium	EtEnf Low	EtEnf Too Low
Medium	EtEnf High	EtEnf Too High
Medium	FiEnf Low	FiEnf Too Low
Medium	FiEnf High	FiEnf Too High
Medium	EtIso Low	EtIso Too Low
Medium	EtIso High	EtIso Too High
Medium	FiIso Low	FiIso Too Low
Medium	FiIso High	FiIso Too High
Medium	EtSev Low	EtSev Too Low
Medium	EtSev High	EtSev Too High
Medium	FiSev Low	FiSev Too Low
Medium	FiSev High	FiSev Too High
Medium	EtDes Low	EtDes Too Low
Medium	EtDes High	EtDes Too High
Medium	FiDes Low	FiDes Too Low
Medium	FiDes High	FiDes Too High
Medium	FiO ₂ High	FiO ₂ Too High
Medium	FiCO ₂ Low	FiCO ₂ Too Low
Low	Pressure limiting	Pressure Limiting
Technical alarms		
High	Drive Gas Pressure Low	Drive Gas Pressure Low
High	No Fresh Gas	No Fresh Gas

Monitor output: alarms from Mindray A9/A8/A7/A5/A4/A3/WATO 25/60/50/30/20/35/55/65/55/65 anesthesia machine		
Mindray Patient Monitor		Mindray A9/A8/A7/A5/A4/A3/WATO Alarm
Priority	Label	Label
High	O ₂ Supply Failure	O2 Supply Failure
High	High Technical alarms	<p>If the monitor shows the alarm [High Technical alarms], the external device may have the following alarms:</p> <ul style="list-style-type: none"> Negative Pressure Check Flow Sensors O₂-N₂O Ratio Error Flowmeter Comm Stop Aux Control Module Comm Stop Power System Comm Stop System DOWN for battery depletion!Power Board High Temp Breathing Circuit Not MountedFlowmeter Cal. Data Error 01/02 Flowmeter Hardware Malfunction 01/02/03/04/05/06/07 Ventilator Hardware Malfunction 01/02/03/04/05/06/07/08/09/10/11/12 Aux Control Module Comm Error Power Supply Voltage Error Low Battery Voltage! Backup Flow Control Deployment Failure Flowmeter Comm ErrorAuxi Ctrl Module Hardware Error 01/02/03/04/05 Ventilator Comm Error Ventilator Selftest Error Power System Comm Error Keyboard Init Error RT Clock Need Reset RT Clock Not Exist Mechanical Ventilation Failure Paw < -10cmH₂O Device Fault, Ventilate Manually

Monitor output: alarms from Mindray A9/A8/A7/A5/A4/A3/WATO 25/60/50/30/20/35/55/65/55/65 anesthesia machine		
Mindray Patient Monitor		Mindray A9/A8/A7/A5/A4/A3/WATO Alarm
Priority	Label	Label
High	High Technical alarms	<p>If the monitor shows the alarm [High Technical alarms], the external device may have the following alarms:</p> <p>Incompatible AG Software Version BIS Module Error BISx Error Incompatible CO2 Software Version CO2 Module Error O2 Module Error Volume Exchanger not MountedVaporizer Dock FailureAuto/Manual Switching Failure Iso Vaporizer Lock Device Failure Sev Vaporizer Lock Device Failure Des Vaporizer Lock Device Failure Tube Disconnected? Battery Failure NMT Comm Abnormal NMT Comm Stop NMT Comm Error NMT Initialization Error NMT Self Test Error NMT Power Failure NMT Module Error Des Vaporizer Output Abnormal Sev Vaporizer Output Abnormal Iso Vaporizer Failure Sev Vaporizer Failure Des Vaporizer Failure Des Vaporizer Selftest Error Sev Vaporizer Selftest Error Iso Vaporizer Selftest Error Des Vaporizer Comm Stop Sev Vaporizer Comm Stop Iso Vaporizer Comm Stop Iso Vaporizer Output Abnormal</p>

Monitor output: alarms from Mindray A9/A8/A7/A5/A4/A3/WATO 25/60/50/30/20/35/55/65/55/65 anesthesia machine		
Mindray Patient Monitor		Mindray A9/A8/A7/A5/A4/A3/WATO Alarm
Priority	Label	Label
High	High Technical alarms	<p>If the monitor shows the alarm [High Technical alarms], the external device may have the following alarms:</p> <ul style="list-style-type: none"> Vaporizer Dock Failure Auto Ventilation is Non-Functional Status Screen Comm Stop Aux O2/AIR Comm Stop HFNC Module Comm Stop O2 Supply Failure, Des Vaporizer Stopped O2 Supply Failure, Sev Vaporizer Stopped O2 Supply Failure, Iso Vaporizer Stopped Aux Control Module Voltage Error
Medium	Patient Circuit Leak	Patient Circuit Leak
Medium	Medium Technical alarms	<p>If the monitor shows the alarm [Medium Technical alarms], the external device may have the following alarms:</p> <ul style="list-style-type: none"> PEEP Valve Failure Insp Valve Failure ACGO 3-way Valve Failure Replace O₂ Sensor Battery Undetected IP Address Conflict Pressure Monitoring Channel Failure Ventilator Comm Stop CO2 Canister Not Mounted Electronic Flow Control Error Backup Flow Control Retraction Failure Air Supply Failure N2O not detected Backup Flow Control Valves Open Total Flow Sensor Self Test Time Backup Flow Control Error PEEP Safety Valve Failure Insp Reverse Flow Exp Reverse Flow

Monitor output: alarms from Mindray A9/A8/A7/A5/A4/A3/WATO 25/60/50/30/20/35/55/65/55/65 anesthesia machine		
Mindray Patient Monitor		Mindray A9/A8/A7/A5/A4/A3/WATO Alarm
Priority	Label	Label
Medium	Medium Technical alarms	<p>If the monitor shows the alarm [Medium Technical alarms], the external device may have the following alarms:</p> <p>Out</p> <p>ACGO On</p> <p>TVe Below Control Range</p> <p>Key Error</p> <p>O₂ Flush Failure</p> <p>Auto Ventilation is Non-Functional - Leak Test Failed</p> <p>Esophageal Pressure Sensor Failure</p> <p>Des Vaporizer Almost Empty</p> <p>Iso Vaporizer Almost Empty</p> <p>Sev Vaporizer Almost Empty</p> <p>Des Vaporizer Liquid Level Sensor Failure</p> <p>Iso Vaporizer Liquid Level Sensor Failure</p> <p>Sev Vaporizer Liquid Level Sensor Failure</p> <p>Aux O2/AIR Failure</p> <p>Aux O2/AIR Selftest Error</p> <p>HFNC Module Failure</p> <p>HFNC Selftest Error</p> <p>Manual Only</p> <p>Manual Only - Leak Test Failed</p> <p>AGSS Failure</p>

Monitor output: alarms from Mindray A9/A8/A7/A5/A4/A3/WATO 25/60/50/30/20/35/55/65/55/65 anesthesia machine		
Mindray Patient Monitor		Mindray A9/A8/A7/A5/A4/A3/WATO Alarm
Priority	Label	Label
Medium	AG Module Abnormal	<p>If the monitor shows the alarm [AG Module Abnormal], the external device may have the following alarms:</p> <ul style="list-style-type: none"> AG Hardware Error O₂ Sensor Error External AG Self Test Error AG Hardware Malfunction AG Init Error AG No Watertrap AG Watertrap Type Wrong AG Change Watertrap AG Comm Stop AG Airway Occluded AG Comm Error AG Data Limit Error AG Zero Failed AG Cal. Failed AG Accuracy Error O₂/N₂O/CO₂/Enf/Iso/Sev/Hal/Des Accuracy Unspecified Mixed anesthetic gas and MAC < 3 Mixed anesthetic gas and MAC >=3 EtCO₂/FiCO₂/EtN₂O/FiN₂O/EtHal/FiHal/EtEnf/FiEnf/EtIso/FiIso/EtSev/FiSev/EtDes/FiDes/EtO₂/FiO₂ Over Range Internal AG Error 01 02 03 04 05 06 07 08 09 10 11 12

Monitor output: alarms from Mindray A9/A8/A7/A5/A4/A3/WATO 25/60/50/30/20/35/55/65/55/65 anesthesia machine		
Mindray Patient Monitor		Mindray A9/A8/A7/A5/A4/A3/WATO Alarm
Priority	Label	Label
Medium	BIS Module abnormal	<p>If the monitor shows the alarm [BIS Module Abnormal], the external device may have the following alarms:</p> <ul style="list-style-type: none"> BIS Init Error BISx Disconnected BIS Comm Error BIS Over Range BIS High Imped. BIS Sensor Off BIS DSC Error BIS DSC Malf BIS No Cable BIS No Sensor BIS Wrong Sensor Type BIS SQI<50% BIS SQI<15% BIS Sensor Expired BIS Sensor Fault BIS Sensor Too Many Uses Disconnect/Reconnect BIS BIS Self Test Error BIS L Over Range BIS R Over Range BIS SQI L<15% BIS SQI L<50% BIS SQI R<15% BIS SQI R<50%
Low	Battery in Use	Battery in Use
Low	O ₂ Sensor Unconnected	O2 Sensor Disconnected

Monitor output: alarms from Mindray A9/A8/A7/A5/A4/A3/WATO 25/60/50/30/20/35/55/65/55/65 anesthesia machine		
Mindray Patient Monitor		Mindray A9/A8/A7/A5/A4/A3/WATO Alarm
Priority	Label	Label
Low	Low Technical alarms	<p>If the monitor shows the alarm [Low Technical alarms], the external device may have the following alarms:</p> <ul style="list-style-type: none"> Flow Sensor Failure Pinsp Not Achieved TV Not Achieved Calibrate O₂ Sensor Heating Module Failure Auto Vent UNUSEBIS Electrode Unconnected BIS Electrode 1/2/3/4 Lead Off BIS Electrode 1/2/3/4 High Imped. N2O Flow High O2 Flow High Air Flow High Flowmeter zero cal errACGO Not found Branch Flow Not Achieved Balance Gas Branch Flow Not Achieved Backup Flow Control is enabled Flowmeter Comm Stop Calibrate Flow Sensor Calibrate PEEP Valve TV Comp Disabled TVe > TVi N2O Sensor Error O2 Sensor Error Air Sensor Error 3-way Valve Failure Sensor Zero Failed TV Delivery High Flowmeter Zero Failed Ventilator Init Error

Monitor output: alarms from Mindray A9/A8/A7/A5/A4/A3/WATO 25/60/50/30/20/35/55/65/55/65 anesthesia machine		
Mindray Patient Monitor		Mindray A9/A8/A7/A5/A4/A3/WATO Alarm
Priority	Label	Label
Low	Low Technical alarms	<p>If the monitor shows the alarm [Low Technical alarms], the external device may have the following alarms:</p> <ul style="list-style-type: none"> BIS Electrode G High BIS Electrode G Lead Off BIS Electrode C High BIS Electrode C Lead Off BIS Electrode LE High BIS Electrode LE Lead Off BIS Electrode LT High BIS Electrode LT Lead Off BIS Electrode RE High BIS Electrode RE Lead Off BIS Electrode RT High BIS Electrode RT Lead Off BIS Signal Quality Too Low BIS Low Signal Quality BIS L Signal Quality Too Low BIS L Low Signal Quality BIS R Signal Quality Too Low BIS R Low Signal Quality BIS Electrode Poor Contact BIS Electrode 1 Poor Contact BIS Electrode 2 Poor Contact BIS Electrode 3 Poor Contact BIS Electrode 4 Poor Contact BIS Electrode G Poor Contact BIS Electrode C Poor Contact BIS Electrode LE Poor Contact BIS Electrode LT Poor Contact BIS Electrode RE Poor Contact BIS Electrode RT Poor Contact

Monitor output: alarms from Mindray A9/A8/A7/A5/A4/A3/WATO 25/60/50/30/20/35/55/65/55/65 anesthesia machine		
Mindray Patient Monitor		Mindray A9/A8/A7/A5/A4/A3/WATO Alarm
Priority	Label	Label
Low	Low Technical alarms	<p>If the monitor shows the alarm [Low Technical alarms], the external device may have the following alarms:</p> <ul style="list-style-type: none"> CO2 Change Watertrap Calibrate Esophageal Pressure Sensor AMV: Cannot Meet Target Calibrate Flow Sensor and Insp Valve Calibrate Pressure Sensor and PEEP Valve awRR Over Range NMT No Main Cable NMT No Sensor NMT Stimulation Electrode Off NMT Sensor Comm Error NMT Stimulation Current Over Limit ST-Ratio Overrange TOF-Ratio Overrange DBS-Ratio Overrange NMT Sensor Error Des Vaporizer Liquid Level Low Sev Vaporizer Liquid Level Low Iso Vaporizer Liquid Level Low Calibrate Aux O2/AIR Module Calibrate HFNC Module AGSS Scavenging Flow is Too High EtO2 Over Range FIO2 Over Range

3.13.3 Output Signals - Waveforms (For BeneVision N series Monitors)

NOTE

- The patient monitor does not output waveforms from the WATO50/30/25/20 anesthesia machines.

Label	Units
Paw	cmH2O, mbar, hpa
Flow	L/min
Vol	mL
CO2	mmHg, kPa,%
O2	%
N2O	%
AA	%
Hal	%
Des	%
Sev	%
Enf	%
Iso	%
Ptp	cmH2O, mbar, hpa
Pes	cmH2O, mbar, hpa

3.13.4 Output Signals – Respiratory Loops (For BeneVision N series Monitors)

NOTE

- The patient monitor does not output respiratory loops from the WATO50/30/25/20 anesthesia machines.

Label	Units
PV Loop	cmH2O/ml, hPa/ml, mbar/ml
FV Loop	L/min/ml
PF Loop	cmH2O/L/min, hPa/L/min, mbar/L/min

This page intentionally left blank.

4 Integrating the Ventilator

4.1 ACUTRONIC Fabian HFO (For BeneVision N series Monitors)

4.1.1 Output Signals - Parameters

Monitor output: parameters from ACUTRONIC Fabian HFO ventilator			
Labels	Units	Description	Trend, record, print
Monitoring Parameters			
EtCO2	%, mmHg, kPa	End-tidal carbon dioxide	Yes
PR	/min	Pulse rate	Yes
VTi	ml	Inspired tidal volume	Yes
FiO2%	%	Fractional concentration of O2 in inspired gas	Yes
RSBI	1/(min.L)	Rapid shallow breathing index	Yes
VTe spn	ml	Spontaneous expiratory tidal volume	Yes
Leak Comp	%	Leak compensation	No
FiCO2	%, mmHg, kPa	Fraction of inspired carbon dioxide	Yes
ftotal	/min	Total respiratory rate	Yes
Ppeak	cmH2O, mbar, hPa	Peak pressure	Yes
MV	L/min	Minute volume	Yes
TVe/IBW	ml/kg	TVe/IBW	Yes
Pmean	cmH2O, mbar, hPa	Mean pressure	Yes
Rdyn	cmH2O/L/s, mbar/L/s, hPa/L/s	Dynamic lung resistance	Yes
C20/C	\	Compliance Ratio	Yes

Monitor output: parameters from ACUTRONIC Fabian HFO ventilator			
Labels	Units	Description	Trend, record, print
Cdyn	ml/cmH2O, ml/ mbar, ml/hPa	Dynamic compliance	Yes
PEEP	cmH2O, mbar, hPa	Positive end-expiratory pressure	Yes
Tinsp	sec	Time of inspiration	Yes
Exp Flow	L/min	Expiratory flow	No
RRCO2	bpm	Respiratory rate of CO2	Yes
TVe	ml	Expiratory tidal volume	Yes
Insp. Flow	L/min	Inspiratory flow	No
SpO2	%	Arterial oxygen saturation from pulse oximetry	Yes
TVe(HFO Mode)	ml	Expiratory tidal volume	Yes
Setting Parameters			
Tinsp	sec	Time of inspiration	No
Pinsp	cmH2O, mbar, hPa	Pressure control level of inspiration	No
f	/min	Breath rate	No
I:E	/	Inspiratory time:Expiratory time ratio	No
Apnea Tinsp	sec	Apnea time	No
Pinsp(PS V Mode)	cmH2O, mbar, hPa	Pressure control level of inspiration	No
PEEP/ CPAP	cmH2O, mbar, hPa	PEEP/CPAP	No
O2%	%	Oxygen concentration	No
Flow	L/min	Flow	No

4.1.2 Output Signals - Alarms

Monitor output: alarms from ACUTRONIC Fabian HFO ventilator		
Mindray Patient Monitor		ACUTRONIC Fabian HFO Alarm
Priority	Label	Label
Physiological alarms		
High	MV High	High minute volume
	MV Low	Low minute volume
	Ppeak High	Pressure too high
	Ppeak Low	Low PIP
	PEEP High	High PEEP value
	PEEP Low	Low PEEP value
	Apnea	Apnea alarm
	Pinsp Not Achieved	Inspiratory Pressure not reached
	SpO2 High	High SPO2
	SpO2 Low	Low SPO2
	PR High	High PulseRate
	PR Low	Low PulseRate
	FiO2 High	High FICO2
	FiO2 Low	Low FICO2
Medium	RR High	High breath rate
	EtCO2 High	High ETCO2 value
	EtCO2 Low	Low ETCO2 value
	FiCO2 High	High FICO2
Technical alarms		
High	Check Flow Sensors	Clean flow sensor
High	Power Failure	Power Failure
High	Patient Disconnected	Patient Disconnected

Monitor output: alarms from ACUTRONIC Fabian HFO ventilator		
Mindray Patient Monitor		ACUTRONIC Fabian HFO Alarm
Priority	Label	Label
High	High Technical Alarm	If the monitor shows the alarm [High Technical alarms], the external device may have the following alarms: High ET tube leak Low physical memory Charge battery (<15min)
Medium	Low DCO2	Low DCO2 value
Medium	Medium Technical Alarm	If the monitor shows the alarm [Medium Technical Alarm], the external device may have the following alarms: SPO2 module not connected PRICO FiO2 outOfRange SPO2 sensor faulty SPO2 low SIQ Nebulizer disconnection Nebulizer system error High DCO2 value CO2 module not connected Clean flow sensor CO2 FilterLine not connected Limited Volume
Low	Check tubing	If the monitor shows the alarm [Check tubing], the external device may have the following alarms: Tube occlusion ET tube blocked

4.1.3 Output Signals - Waveforms (For BeneVision N series Monitors)

Label	Units
Paw	cmH2O, mbar, hpa
Flow	L/min
Vol	mL

4.2 AirLiquide ALMS Monnal T75

4.2.1 Output Signals - Parameters

Monitor output: parameters from AirLiquide ALMS Monnal T75 ventilator			
Labels	Units	Description	Trend, record, print
Monitoring Parameters			
PEEP	cmH2O, hPa, mbar	Positive end-expiratory pressure	Yes
Ppeak	cmH2O, hPa, mbar	Peak pressure	Yes
Pplat	cmH2O, hPa, mbar	Plateau pressure	Yes
Pmean	cmH2O, hPa, mbar	Mean pressure	Yes
TVe	ml	Expiratory tidal volume	Yes
TVi	ml	Inspiratory tidal volume	Yes
MVe	L/min	Expiratory minute volume	Yes
ftotal	/min	Total respiratory rate	Yes
FiO ₂	%,kPa,mmHg	Fractional concentration of O ₂ in inspired gas	Yes
FiO ₂ %	%	Fractional concentration of O ₂ in inspired gas	Yes
EtCO ₂	%,kPa,mmHg	End-tidal carbon dioxide	Yes
Setting Parameters			
TV	ml	Tidal volume	No
f	/min	Breath rate	No
PEEP	cmH2O, hPa, mbar	Positive end-expiratory pressure	No
I:E	\	Inspiratory time:Expiratory time ratio	No
ΔPsupp	cmH2O, hPa, mbar	Pressure support level	No
Tinsp	sec	Time of inspiration	No

4.2.2 Output Signals - Alarms

Monitor output: alarms from AirLiquide ALMS Monnal T75 ventilator		
Mindray Patient Monitor		AirLiquide ALMS Monnal T75 Alarm
Priority	Label	Label
Physiological alarms		
High	Apnea Ventilation	Apnea ventilation
High	TV Not Achieved	VT not reached
High	CO ₂ Apnea	CO2 apnea
High	Apnea	Apnea
High	FiO ₂ High	High FiO2
High	FiO ₂ Low	Low FiO2
High	FiO2 Alarm	100% FiO2 during 2 min
High	MV High	High MVe
High	MV Low	Low MVe
High	Paw High	High pressure
High	Ppeak High	High Ppeak
High	Ppeak Low	Patient demand higher than set peak flow
Medium	EtCO ₂ High	High etCO2
Medium	EtCO ₂ Low	Low etCO2
Medium	FiCO ₂ High	High FiCO2
Medium	PEEPe High	PEEP greater than set PEEP + 5 cmH2O
Medium	RR High	High RR
Medium	RR Low	Low RR
Medium	TVe High	High VTe
Medium	TVe Low	Low VTe
Low	Plimit Reached	PI limit reached
Technical alarms		
High	Airway Obstructed?	Expiration blocked

Monitor output: alarms from AirLiquide ALMS Monnal T75 ventilator		
Mindray Patient Monitor		AirLiquide ALMS Monnal T75 Alarm
Priority	Label	Label
High	Check Flow Sensors	Expiratory flow sensor failure Inspiratory flow sensor failure
High	O ₂ Supply Pressure Low	O2 supply failure
High	Patient Disconnected	Patient disconnection
High	High Technical Alarm	If the monitor shows the alarm [High Technical alarms], the external device may have the following alarms: Internal battery low O ₂ sensor failure Restart self-tests Technical failure detected Ventilator inoperative Minor failure detected Adjust ventilation parameters Nurse Call Internal battery failure Air supply failure N2O supply failure Xe supply failure N2O sensor failure Xe sensor failure AA sensor failure Gas analyzer failure Hypoxic mix PS limit reached Slow Inflation in progress Sustained exhalation in progress Maximum FIO2 during 2 min
High	High Technical Alarm	O2 flush in progress O2 monitoring disabled Expiratory monitoring disabled High AA Low AA Low FICO2

Monitor output: alarms from AirLiquide ALMS Monnal T75 ventilator		
Mindray Patient Monitor		AirLiquide ALMS Monnal T75 Alarm
Priority	Label	Label
Medium	Medium Technical Alarm	If the monitor shows the alarm [Medium Technical alarms], the external device may have the following alarms: Internal battery discharged
Low	Airway Leak?	Important leak
Low	Battery in Use	Ventilator operates from external battery Ventilator operates from internal battery
Low	Low Technical Alarm	If the monitor shows the alarm [Low Technical alarms], the external device may have the following alarms: Maintenance required CO2 sensor failure

4.3 Carefusion Avea(VOXP)

4.3.1 Output Signals - Parameters

Monitor output: parameters from Carefusion Avea ventilator			
Labels	Units	Description	Trend, record, print
Monitoring Parameters			
C20/C	\	Compliance Ratio	Yes
Cdyn	ml/cmH2O,ml/hPa,ml/mbar	Dynamic compliance	Yes
Cstat	ml/cmH2O,ml/hPa,ml/mbar	Static compliance	Yes
O2%	%	Oxygen concentration	Yes
I:E	\	Inspiratory time: Expiratory time ratio	Yes
Leak Comp	%	Leak compensation	No
PEEP	cmH2O, hPa, mbar	Positive end-expiratory pressure	Yes

Monitor output: parameters from Carefusion Avea ventilator			
Labels	Units	Description	Trend, record, print
Exp.Flow	L/min	Expiratory flow	No
Insp Flow	L/min	Inspiratory flow	No
Pmean	cmH2O, hPa, mbar	Mean pressure	Yes
PO2	kPa	Oxygen supply pressure	No
Ppeak	cmH2O, hPa, mbar	Peak pressure	Yes
Pplat	cmH2O, hPa, mbar	Plateau pressure	Yes
ftotal	/min	Total breath rate	Yes
fspn	/min	Spontaneous respiratory rate	Yes
Vdel	ml	Total volume of gas delivered	No
MVspn	L/min	Spontaneous breathed minute volume	Yes
WOB	J/L	Work of breathing	Yes
TVi	ml	Inspired tidal volume	Yes
TVe spn	ml	Spontaneous expiratory tidal volume	Yes
TVe/IBW	ml/kg	TVe/IBW	Yes
TVe Mand	ml	Mandatory Expiratory tidal volume	No
TVe	ml	Expiratory tidal volume	Yes
MVe	L/min	Expiratory minute volume	Yes
Tinsp	sec	Time of inspiration	Yes
Texp	sec	Expiratory time	Yes
Ri	cmH2O/L/s, hPa/L/s, mbar/L/s	Inspiratory resistance	Yes
RSBI	1/(min.L)	Rapid shallow breathing index	Yes
Pair	kPa	Air supply pressure	No
P0.1	cmH2O, hPa, mbar	100 ms occlusion pressure	No
PEEPi	cmH2O, hPa, mbar	Intrinsic positive end-expiratory pressure	Yes
PEEPe	cmH2O, hPa, mbar	Extrinsic positive end-expiratory pressure	No

Monitor output: parameters from Carefusion Avea ventilator			
Labels	Units	Description	Trend, record, print
Re	cmH2O/L/s,hPa/L/s,mbar/L/s	Expiratory resistance	Yes
fmand	/min	Mandatory breathing frequency	Yes
NIF	cmH2O, hPa, mbar	Negative inspiratory force	No
Setting Parameters			
O2%	%	Fractional concentration of O2 in inspired gas	No
Base Flow	L/min	Base Flow	No
Exp%	%	Inspiration termination level	No
Peak Flow	L/min	Peak flow	No
Tpause	sec	Pause Time	No
Phigh	cmH2O, hPa, mbar	Upper pressure level	No
Plow	cmH2O, hPa, mbar	Lower pressure level	No
PEEP	cmH2O, hPa, mbar	Positive end-expiratory pressure	No
Δ Psupp	cmH2O, hPa, mbar	Pressure support level	No
f	/min	Breath rate	No
Tslope	sec	Rise time	No
Tinsp	sec	Time of inspiration	No
Tlow	sec	Time for the lower pressure level	No
F-Trig	L/min	Inspiratory trigger level (flow trigger)	No
P-Trig	cmH2O, hPa, mbar	Inspiratory trigger level (pressure trigger)	No
TV	ml	Tidal volume	No
Pinsp	cmH2O, hPa, mbar	Pressure control level of inspiration	No
Thigh	sec	Time for the upper pressure level	No
Ti Max	sec	Maximum inspiration time	No

4.3.2 Output Signals - Alarms

Monitor output: alarms from Carefusion Avea ventilator		
Mindray Patient Monitor		Carefusion Avea Alarm
Priority	Label	Label
Physiological alarms		
High	Ppeak High	HIGH Ppeak
High	PEEP Low	LOW PEEP
High	MV Low	LOW Ve
High	MV High	HIGH Ve
High	FiO2 Low	LOW FIO2
High	FiO2 High	HIGH FIO2
High	Ppeak Low	LOW Ppeak
Medium	RR High	HIGH RATE
Medium	TVe Low	LOW Vte
Medium	TVe High	HIGH Vte
Technical alarms		
High	High Technical alarms	<p>If the monitor shows the alarm [High Technical alarms], the external device may have the following alarms:</p> <ul style="list-style-type: none"> Vent Inop Loss of Gas Circuit Disconnect Ext High Ppeak Safety Valve CIRCUIT OCCLUSION Apnea Interval Loss of O2 Loss of Air Loss of Heliox Low Battery Loss of A/C ILV Disconnect

Monitor output: alarms from Carefusion Avea ventilator		
Mindray Patient Monitor		Carefusion Avea Alarm
Priority	Label	Label
Medium	Medium Technical alarms	If the monitor shows the alarm [Medium Technical alarms], the external device may have the following alarms: Invalid Gas ID Fan Failure
Low	Low Technical alarms	If the monitor shows the alarm [Low Technical alarms], the external device may have the following alarms: Insp Time Limit I:E Limit Volume Limit

4.3.3 Output Signals - Waveforms (For BeneVision N series Monitors)

Label	Units
Paw	cmH2O, mbar, hPa
Flow	L/min
Vol	mL

4.4 Carefusion Vela

4.4.1 Output Signals - Parameters

Monitor output: parameters from Carefusion Vela ventilator			
Labels	Units	Description	Trend, record, print
Monitoring Parameters			
PEEP	cmH2O, hPa, mbar	Positive end-expiratory pressure	Yes
Ppeak	cmH2O, hPa, mbar	Peak pressure	Yes
Pmean	cmH2O, hPa, mbar	Mean pressure	Yes
TVe	ml	Expiratory tidal volume	Yes

Monitor output: parameters from Carefusion Vela ventilator			
Labels	Units	Description	Trend, record, print
TVi	ml	Inspired tidal volume	Yes
TVe spn	ml	Spontaneous expiratory tidal volume	Yes
MVspn	L/min	Spontaneous breathed minute volume	Yes
MVe	L/min	Expiratory minute volume	Yes
ftotal	/min	Total breath rate	Yes
fspn	/min	Spontaneous respiratory rate	Yes
I:E	\	Inspiratory time:Expiratory time ratio	Yes
FiO2%	%	Fractional concentration of O ₂ in inspired gas	Yes
FiO ₂	%,kPa,mmHg	Fractional concentration of O ₂ in inspired gas	Yes
Texp	sec	Expiratory time	Yes
PO ₂	kPa	Oxygen supply pressure	No
EtCO ₂	%,kPa,mmHg	End-tidal carbon dioxide	Yes
RSBI	1/(min.L)	Rapid shallow breathing index	Yes
Setting Parameters			
PEEP	cmH2O, hPa, mbar	Positive end-expiratory pressure	No
TV	ml	Tidal volume	No
f	/min	Breath rate	No
Base Flow	L/min	Base Flow	No
F-Trig	L/min	Inspiratory trigger level (flow trigger)	No
△Psupp	cmH2O, hPa, mbar	Pressure support level	No
Tinsp	sec	Time of inspiration	No
Pinsp	cmH2O, hPa, mbar	Pressure control level of inspiration	No
Phigh	cmH2O, hPa, mbar	Upper pressure level	No
Plow	cmH2O, hPa, mbar	Lower pressure level	No

Monitor output: parameters from Carefusion Vela ventilator			
Labels	Units	Description	Trend, record, print
Thigh	sec	Time for the upper pressure level	No
Tlow	sec	Time for the lower pressure level	No
Exp%	%	Inspiration termination level	No
Peak Flow	L/min	Peak flow	No
Ti max	sec	Maximum inspiration time	No
O2%	%	Oxygen concentration	No
Tpause	sec	Pause Time	No

4.4.2 Output Signals - Alarms

Monitor output: alarms from Carefusion Vela ventilator		
Mindray Patient Monitor		Carefusion Vela Alarm
Priority	Label	Label
Physiological alarms		
High	MV Low	Low Ve
High	Apnea	APNEA INTERVAL
High	PEEP High	HIGH PEEP
High	Ppeak High	HIGH PIP or HIGH PIP SUST
High	Ppeak Low	LOW PIP
High	FiO ₂ Alarm	%O ₂ RANGE ERROR
Medium	EtCO ₂ High	High EtCO ₂
Medium	EtCO ₂ Low	Low EtCO ₂
Medium	RR High	HIGH RATE
Technical alarms		
High	O ₂ cell cal. Needed	CHECK O ₂ CAL
High	O ₂ Supply Pressure Low	O ₂ Inlet LOW
High	Circuit Disconnect	Circuit FAULT

Monitor output: alarms from Carefusion Vela ventilator		
Mindray Patient Monitor		Carefusion Vela Alarm
Priority	Label	Label
High	High Technical alarms	If the monitor shows the alarm [High Technical alarms], the external device may have the following alarms: LOW BATTERY MOTOR FAULT VENT INOP H/W FAULT
Medium	Medium Technical alarms	If the monitor shows the alarm [Medium Technical alarms], the external device may have the following alarms: CHECK EVENTS LOW CLOCK BATTERY CO ₂ COMMS ERROR CO ₂ Out Of Range CO ₂ Sensor Fault CO ₂ Sensor Temp CO ₂ Zero Reqd FAN FAILURE CO ₂ Check Adapter DEFAULTS O ₂ SENSOR FAILURE Invalid EtCO ₂ O ₂ INLET HIGH MED BATTERY XDCCR FAULT
Low	Battery in Use	ON BATTERY POWER
Low	Low Technical alarms	If the monitor shows the alarm [Low Technical alarms], the external device may have the following alarms: INVALID SERIAL NUMBER NO CAL DATA

4.5 Draeger Babylog 8000 plus/Babylog 8000

4.5.1 Output Signals - Parameters

Monitor output: parameters from Draeger Babylog 8000 plus/Babylog 8000 ventilator			
Labels	Units	Description	Trend, record, print
Monitoring Parameters			
Cdyn	ml/cmH2O,ml/hPa,ml/mbar	Dynamic compliance	Yes
Rdyn	cmH2O/L/s,hPa/L/s,mbar/L/s	Dynamic lung resistance	Yes
Pmean	cmH2O, hPa, mbar	Mean pressure	Yes
PEEP	cmH2O, hPa, mbar	Positive end-expiratory pressure	Yes
Ppeak	cmH2O, hPa, mbar	Peak pressure	Yes
TVi	ml	Inspired tidal volume	Yes
Leak Comp	%	Leak compensation	No
MV	L/min	Minute volume	Yes
ftotal	/min	Total respiratory rate	Yes
FiO ₂	%,kPa,mmHg	Fractional concentration of O ₂ in inspired gas	Yes
FiO ₂ %	%	Fractional concentration of O ₂ in inspired gas	Yes
Setting Parameters			
O ₂ %	%	Oxygen concentration	No
T _{insp}	sec	Time of inspiration	No
f _{simv}	/min	Frequency of SIMV	No
PEEP/CPAP	cmH2O, hPa, mbar	PEEP/CPAP	No
Apnea T _{insp}	sec	Apnea time	No
P _{max}	cmH2O, hPa, mbar	Maximum airway pressure	No
f	/min	Breath rate	No
TV	ml	Tidal volume	No

Monitor output: parameters from Draeger Babylog 8000 plus/Babylog 8000 ventilator			
Labels	Units	Description	Trend, record, print
I:E	\	Inspiratory time:Expiratory time ratio	No

4.5.2 Output Signals - Technical Alarms

Monitor output: alarms from Draeger Babylog 8000 plus/Babylog 8000 ventilator		
Mindray Patient Monitor		Babylog 8000 plus/Babylog 8000 Alarm
Priority	Label	Label
Medium	Medium Technical Alarm	If the monitor shows the alarm [Medium Technical alarms], the external device may have the following alarms: VOL ERR % O ₂ ERR

4.6 Draeger Babylog VN500/VN800

4.6.1 Output Signals - Parameters

Monitor output: parameters from Draeger Babylog VN500 ventilator			
Labels	Units	Description	Trend, record, print
Monitoring Parameters			
Cdyn	ml/cmH ₂ O,ml/hPa,ml/mbar	Dynamic compliance	Yes
Rdyn	cmH ₂ O/L/s,hPa/L/s,mbar/L/s	Dynamic lung resistance	Yes
VCO ₂	ml/min	CO ₂ production	No
Pmin	cmH ₂ O, hPa, mbar	Minimum airway pressure	No
Pmean	cmH ₂ O, hPa, mbar	Mean pressure	Yes
PEEP	cmH ₂ O, hPa, mbar	Positive end-expiratory pressure	Yes
fmand	/min	Mandatory breathing frequency	Yes
Ppeak	cmH ₂ O, hPa, mbar	Peak pressure	Yes

Monitor output: parameters from Draeger Babylog VN500 ventilator			
Labels	Units	Description	Trend, record, print
TVe spn	ml	Spontaneous expiratory tidal volume	Yes
Mvleak	L/min	Leakage minute volume	Yes
Leak Comp	%	Leak compensation	No
fspn	/min	Spontaneous respiratory rate	Yes
MV	L/min	Minute volume	Yes
RSBI	1/(min.L)	Rapid shallow breathing index	Yes
ftotal	/min	Total respiratory rate	Yes
EtCO2%	%	End-tidal carbon dioxide	Yes
EtCO2	%,kPa,mmHg	End-tidal carbon dioxide	Yes
I:E	\	Inspiratory time: Expiratory time ratio	Yes
FiO2%	%	Fractional concentration of O ₂ in inspired gas	Yes
FiO2	%,kPa,mmHg	Fractional concentration of O ₂ in inspired gas	Yes
MVe	L/min	Expiratory minute volume	Yes
MVi	L/min	Inspiratory minute volume	Yes
TVe	ml	Expiratory tidal volume	Yes
TVi	ml	Inspired tidal volume	Yes
TVe/IBW	ml/kg	TVe/IBW	Yes
Setting Parameters			
O2%	%	Fractional concentration of O ₂ in inspired gas	Yes
Flow	L/min	Flow	No
Tinsp	sec	Time of inspiration	No
f	/min	Breath rate	No
PEEP	cmH2O, hPa, mbar	Positive end-expiratory pressure	No
△int.PEEP	cmH2O, hPa, mbar	Intermittent PEEP	No

Monitor output: parameters from Draeger Babylog VN500 ventilator			
Labels	Units	Description	Trend, record, print
Plow	cmH2O, hPa, mbar	Lower pressure level	No
Phigh	cmH2O, hPa, mbar	Upper pressure level	No
Tlow	sec	Time for the lower pressure level	No
Thigh	sec	Time for the upper pressure level	No
Apnea Tinsp	sec	Apnea Time	No
Δ Psupp	cmH2O, hPa, mbar	Pressure support level	No
Pmax	cmH2O, hPa, mbar	Maximal breathing pressure	No
F-Trig	L/min	Inspiratory trigger level (flow trigger)	No
Tslope	sec	Rise time	No
FlowAssist	cmH2O.s/L, hPa.s/L, mbar.s/L	Flow assist	No
Vol Assist	cmH2O/L, hPa/L, mbar/L	Volume assist	No
fapnea	/min	Breath rate for apnea ventilation	No
Pinsp	cmH2O, hPa, mbar	Pressure control level of inspiration	No
ATC	%	Automatic Tube Compensation	No
Tube ID	mm	Tube ID	No
Tdisconnect	sec	Delay time for "Airway pressure lower alarm limit"	No
Ti max	sec	Maximum inspiration time	No
Exp%	%	Inspiration termination level	No
TV	ml	Tidal volume	No
TVapnea	ml	Apnea tidal volume	No
I:E	\	Inspiratory time: Expiratory time ratio	No

4.6.2 Output Signals - Alarms

Monitor output: alarms from Draeger Babylog VN500 ventilator		
Mindray Patient Monitor		Draeger Babylog VN500 Alarm
Priority	Label	Label
Physiological alarms		
High	Paw High	Airway pressure high
High	Paw Low	Airway pressure low
High	MV High	MV high
High	MV Low	MV low
High	FiO ₂ High	FiO2 high
High	FiO ₂ low	FiO2 low
High	PEEP High	PEEP high
High	PEEP Low	PEEP low
High	Apnea Ventilation	Apnea ventilation
High	Apnea	APNEA RESP
Medium	EtCO ₂ High	etCO2 high
Medium	EtCO ₂ Low	etCO2 low
Medium	TVe Low	Tidal volume low
Medium	RR High	High respiratory rate
Medium	VOL INCONST	VT not reached
Technical alarms		
High	Air Supply Pressure Low	Air supply down
High	O ₂ Supply Pressure Low	O2 supply down
High	CLEAN CO ₂	Clean CO2 cuvette
High	Power Failure	Internal power supply failure
High	Check Flow Sensors	Exp Time Err
High	EXP-VALVE?	Expiratory valve malfunction
High	Negative Airway Pressure	Airway pressure negative
High	Neo Flow Sensor Error	Neo. flow sensor changed ?

Monitor output: alarms from Draeger Babylog VN500 ventilator		
Mindray Patient Monitor		Draeger Babylog VN500 Alarm
Priority	Label	Label
High	Circuit Disconnect	Disconnection Ventilator
High	No O2 Pressure	O2 supply down
High	Airway Obstructed?	Tube Obstruct
High	High Technical Alarms	<p>If the monitor shows the alarm [High Technical alarms], the external device may have the following alarms:</p> <p>CO₂ NOT CAL BATTERY ERR SPEAKER FAIL VENT ERR VOL ERR AW TEMP INOP AIR PRESS HI HI O2 SUPPLY SYSTEM FAULT BATTER ERR x COOLING x CO2_NOT_CAL_X LOSS OF DATA HOSE ERR EJECTOR INOP MAP LOW O2 Err PRESS_ERR AW_TEM_SENS INT_TEMP_HI Evita Err CO2 SENSOR</p>

Monitor output: alarms from Draeger Babylog VN500 ventilator		
Mindray Patient Monitor		Draeger Babylog VN500 Alarm
Priority	Label	Label
Medium	Medium Technical Alarms	If the monitor shows the alarm [Medium Technical alarms], the external device may have the following alarms: GAS FAILURE NO AIR AMB_PRESS BATT LOW CHECK_EVITA NEBULIZ OF VT LIMITED
Low	Battery In use	Internal battery activated
Low	Low Technical Alarms	If the monitor shows the alarm [Low Technical alarms], the external device may have the following alarms: CO2 ERR Plow>high limit Plow<low limit VOL CAL

4.6.3 Output Signals - Waveforms (For BeneVision N series Monitors)

NOTE

- The patient monitor does not output waveforms from the Draeger Evita XL ventilator.

Label	Units
Paw	cmH2O, mbar, hpa
Flow	L/min
Vol	mL
CO2	mmHg, kPa, %

4.7 Draeger Evita 2

4.7.1 Output Signals - Parameters

Monitor output: parameters from Draeger Evita 2 ventilator			
Labels	Units	Description	Trend, record, print
PEEP	cmH2O, hPa, mbar	Positive end-expiratory pressure	Yes
Ppeak	cmH2O, hPa, mbar	Peak pressure	Yes
Pplat	cmH2O, hPa, mbar	Plateau pressure	Yes
Pmean	cmH2O, hPa, mbar	Mean pressure	Yes
TVe	ml	Expiratory tidal volume	Yes
MV	L/min	Minute volume	Yes
MVspn	L/min	Spontaneous breathed minute volume	Yes
ftotal	/min	Total respiratory rate	Yes
fspn	/min	Spontaneous breathing frequency	Yes
FiO ₂	%,kPa,mmHg	Fractional concentration of O ₂ in inspired gas	Yes
Rdyn	cmH2O/L/s,hPa/L/s,mbar/L/s	Dynamic lung resistance	Yes
Cdyn	ml/cmH2O,ml/hPa,ml/mbar	Dynamic compliance	Yes
Pmin	cmH2O, hPa, mbar	Minimum airway pressure	No
Vtrap	ml	Trapped volume	No
T	°C, °F	Inspiratory breathing gas temperature	No
P0.1	cmH2O, hPa, mbar	100 ms occlusion pressure	No
PEEPi	cmH2O, hPa, mbar	Intrinsic positive end-expiratory pressure	Yes
EtCO ₂	%,kPa,mmHg	End-tidal carbon dioxide	Yes
Vds	ml	Dead space	No
VCO ₂	ml/min	CO ₂ production	No
EtCO ₂ %	%	End-tidal carbon dioxide	Yes

Monitor output: parameters from Draeger Evita 2 ventilator			
Labels	Units	Description	Trend, record, print
FiO2%	%	Fractional concentration of O ₂ in inspired gas	Yes
Setting Parameters			
O2%	%	Oxygen concentration	No
PEEP	cmH2O, hPa, mbar	Positive end-expiratory pressure	No
TV		Tidal volume	No
fsimv	/min	Frequency of SIMV	No
I:E	\	Inspiratory time:Expiratory time ratio	No
Δint.PEEP	cmH2O, hPa, mbar	Intermittent PEEP	No
F-Trig	L/min	Inspiratory trigger level (flow trigger)	No
P-Trig	cmH2O, hPa, mbar	Inspiratory trigger level (pressure trigger)	No
Phigh	cmH2O, hPa, mbar	Upper pressure level	No
Plow	cmH2O, hPa, mbar	Lower pressure level	No
Thigh	sec	Time for the upper pressure level	No
Tlow	sec	Time for the lower pressure level	No
Pmax	cmH2O, hPa, mbar	Maximum airway pressure	No
Flow	L/min	Flow	No
Apnea Tinsp	sec	Apnea Time	No
ASB ramp	sec	ASB ramp	No
PASB	cmH2O, hPa, mbar	Assisted spontaneous breathing	No

4.7.2 Output Signals - Alarms

Monitor output: alarms from Draeger Evita 2 ventilator		
Mindray Patient Monitor		Draeger Evita 2 Alarm
Priority	Label	Label
Physiological alarms		
High	Paw High	PAW HIGH
High	Paw Low	PAW LOW
High	MV High	MIN VOL HIGH
High	MV Low	MIN VOL LOW
High	Apnea	APNEA EVITA
High	FiO ₂ High	% O2 HIGH
High	FiO ₂ Low	% O2 LOW
High	AW-TEMP HIGH	AW-TEMP HIGH
High	PEEP High	PEEP HIGH
High	ASB>4s	ASB > 4 SEC
Medium	EtCO ₂ High	ET CO2 HIGH
Medium	EtCO ₂ Low	ET CO2 LOW
Medium	VOL INCONST	VOL INCONST
Medium	RR High	RESP RATE HI
Technical alarms		
High	Air Supply Pressure Low	AIR SUPPLY ?
High	Check Flow Sensors	FLOW SENSOR?
High	CLEAN CO ₂	CLEAN CO2
High	EXP-VALVE?	EXP-VALVE?
High	O2 Supply Pressure Low	LO O2 SUPPLY

Monitor output: alarms from Draeger Evita 2 ventilator		
Mindray Patient Monitor		Draeger Evita 2 Alarm
Priority	Label	Label
High	High Technical alarms	<p>If the monitor shows the alarm [High Technical alarms], the external device may have the following alarms:</p> <p>VOL ERR PRESS ERR AW-TEMP INOP AW-TEMP SENS CO₂ NOT CAL % O₂ ERR EVITA ERR COOLING INOP CYCLE FAILED COOLING INOP ADVISORY</p>
Low	Low Technical alarms	<p>If the monitor shows the alarm [Low Technical alarms], the external device may have the following alarms:</p> <p>CO₂ ERR CO₂ SENS? MIXER INOP SYNCHRO INOP MIXER INOP ADV</p>

4.8 Draeger Evita2 dura/Evita 4/Evita XL

4.8.1 Output Signals - Parameters

Monitor output: parameters from Draeger Evita2 dura/Evita 4/Evita XL ventilator			
Labels	Units	Description	Trend, record, print
Monitoring Parameters			
PEEP	cmH2O, hPa, mbar	Positive end-expiratory pressure	Yes
Ppeak	cmH2O, hPa, mbar	Peak pressure	Yes
Pplat	cmH2O, hPa, mbar	Plateau pressure	Yes
Pmean	cmH2O, hPa, mbar	Mean pressure	Yes
TVe	ml	Expiratory tidal volume	Yes
MV	L/min	Minute volume	Yes
MVspn	L/min	Spontaneous breathed minute volume	Yes
ftotal	/min	Total respiratory rate	Yes
fspn	/min	Spontaneous breathing frequency	Yes
FiO ₂	%,kPa,mmHg	Fractional concentration of O ₂ in inspired gas	Yes
Rdyn	cmH2O/L/s,hPa/L/s,mbar/L/s	Dynamic lung resistance	Yes
Cdyn	ml/cmH2O,ml/hPa,ml/mbar	Dynamic compliance	Yes
RSBI	1/(min.L)	Rapid shallow breathing index	Yes
Pmin	cmH2O, hPa, mbar	Minimum airway pressure	No
Vtrap	ml	Trapped Volume	No
T	°C, °F	Inspiratory breathing gas temperature	No
NIF	cmH2O, hPa, mbar	Negative inspiratory force	No
P0.1	cmH2O, hPa, mbar	100 ms occlusion pressure	No
PEEPi	cmH2O, hPa, mbar	Intrinsic positive end-expiratory pressure	Yes
EtCO ₂	%,kPa,mmHg	End-tidal carbon dioxide	Yes

Monitor output: parameters from Draeger Evita2 dura/Evita 4/Evita XL ventilator			
Labels	Units	Description	Trend, record, print
Vds	ml	Dead space	No
VCO ₂	ml/min	CO ₂ production	No
PR	/min	Pulse rate	Yes
SpO ₂	%	Arterial oxygen saturation from pulse oximetry	Yes
EtCO ₂ %	%	End-tidal carbon dioxide	Yes
FiO ₂ %	%	Fractional concentration of O ₂ in inspired gas	Yes
Setting Parameters			
O ₂ %	%	Oxygen concentration	No
PEEP	cmH ₂ O, hPa, mbar	Positive end-expiratory pressure	No
TV	ml	Tidal volume	No
f	/min	Breath rate	No
I:E	\	Inspiratory time: Expiratory time ratio	No
△int.PEEP	cmH ₂ O, hPa, mbar	Intermittent PEEP	No
F-Trig	L/min	Inspiratory trigger level (flow trigger)	No
P _{high}	cmH ₂ O, hPa, mbar	Upper pressure level	No
P _{low}	cmH ₂ O, hPa, mbar	Lower pressure level	No
T _{high}	sec	Time for the upper pressure level	No
T _{low}	sec	Time for the lower pressure level	No
P _{max}	cmH ₂ O, hPa, mbar	Maximum airway pressure	No
T _{insp}	sec	Time of inspiration	No
Flow	L/min	Flow	No
Apnea T _{insp}	sec	Apnea time	No
ASB ramp	sec	ASB ramp	No
PASB	cmH ₂ O, hPa, mbar	Assisted spontaneous breathing	No

Monitor output: parameters from Draeger Evita2 dura/Evita 4/Evita XL ventilator			
Labels	Units	Description	Trend, record, print
FlowAssist	cmH2O.s/L,hPa.s/ L,mbar.s/L	Flow assist	No
Vol.Assist	cmH2O/L,hPa/ L,mbar/L	Volume assist	No
Tdisconne ct	sec	Delay time for "Airway pressure lower alarm limit"	No
Tube ID	mm	Tube ID	No
ATC	%	Automatic Tube Compensation	No
Pinsp	cmH2O, hPa, mbar	Pressure control level of inspiration	No
TVapnea	ml	Apnea tidal volume	No
Papnea	cmH2O, hPa, mbar	Apnea pressure	No
fapnea	/min	Breath rate for apnea ventilation	No

4.8.2 Output Signals - Alarms

Monitor output: alarms from Draeger Evita2 dura/Evita 4/Evita XL ventilator		
Mindray Patient Monitor		Evita2 dura/Evita 4/Evita XL Alarm
Priority	Label	Label
Physiological alarms		
High	Paw High	PAW HIGH
High	Paw Low	PAW LOW
High	MV High	MIN VOL HIGH
High	MV Low	MIN VOL LOW
High	Apnea	APNEA EVITA
High	FiO ₂ High	% O2 HIGH
High	FiO ₂ Low	% O2 LOW
High	AW-TEMP HIGH	AW-TEMP HI
High	PEEP High	PEEP HIGH
High	ASB>4s	ASB > 4 SEC

Monitor output: alarms from Draeger Evita2 dura/Evita 4/Evita XL ventilator		
Mindray Patient Monitor		Evita2 dura/Evita 4/Evita XL Alarm
Priority	Label	Label
High	No Pulse	NO SPO2 PULS
High	PR Low	SPO2 PULS LO
High	SpO ₂ Low	SPO2 LOW
High	PR High	SPO2 PULS HI
High	SpO ₂ High	SPO2 HIGH
Medium	TVe High	TIDVOL HI
Medium	EtCO ₂ High	ET CO2 HIGH
Medium	EtCO ₂ Low	ET CO2 LOW
Medium	VOL INCONST	VOL INCONST
Medium	RR High	RESP RATE HI
Low	ASB > 1.5s	ASB > 1,5 SEC
Low	PPS-TI > 1.5s	PPS-TI > 1,5S
Low	ASB > Tinsp	ASB > TINSP
Technical alarms		
High	Air Supply Pressure Low	AIR SUPPLY?
High	O ₂ Supply Pressure Low	LO O2 SUPPLY
High	Airway Obstructed?	TUBE OBSTRUC
High	Check Flow Sensors	FLOW SENSOR?
High	CLEAN CO ₂	CLEAN CO2
High	EXP-VALVE?	EXP-VALVE?

Monitor output: alarms from Draeger Evita2 dura/Evita 4/Evita XL ventilator		
Mindray Patient Monitor		Evita2 dura/Evita 4/Evita XL Alarm
Priority	Label	Label
High	High Technical alarms	If the monitor shows the alarm [High Technical alarms], the external device may have the following alarms: VOL ERR PRESS ERR AW-TEMP INOP EVITA ERR CYCLE FAILED N-VOL ERR NEO FLOW? CO ₂ ZERO CAL
High	High Technical alarms	If the monitor shows the alarm [High Technical alarms], the external device may have the following alarms: SPO ₂ SEN DISC SPO ₂ ERR BATTERY ERR FAN ERR AIR PRESS HI HI O2 SUPPLY LOSS OF DATA REM.PAD-ERR PEEP V ERR CO2 NOT CAL
Medium	Medium Technical alarms	If the monitor shows the alarm [Medium Technical alarms], the external device may have the following alarms: BATT. < 2MIN CHECK EVITA EVITA STDBY AMB PRESS? NEBULIZ OFF ERR MULTIPCB
Low	Battery in Use	BATTERY ON

Monitor output: alarms from Draeger Evita2 dura/Evita 4/Evita XL ventilator		
Mindray Patient Monitor		Evita2 dura/Evita 4/Evita XL Alarm
Priority	Label	Label
Low	Low Technical alarms	If the monitor shows the alarm [Low Technical alarms], the external device may have the following alarms: CO ₂ ERR CO ₂ SENSOR ? MIXER INOP SYNCHRO INOP INSPHOLD END EXSPHOLD END

4.8.3 Output Signals - Waveforms (For BeneVision N series Monitors)

NOTE

- The patient monitor does not output waveforms from the Draeger Evita XL ventilator.

Label	Units
Paw	cmH ₂ O, mbar, hpa
Flow	L/min
Vol	mL

4.9 Draeger Evita V300

4.9.1 Output Signals - Parameters

Monitor output: parameters from Draeger Evita V300 ventilator			
Labels	Units	Description	Trend, record, print
Monitoring Parameters			
Cdyn	ml/cmH ₂ O,ml/hPa,ml/mbar	Dynamic compliance	Yes

Monitor output: parameters from Draeger Evita V300 ventilator			
Labels	Units	Description	Trend, record, print
Rdyn	cmH2O/L/s,hPa/L/s,mbar/L/s	Dynamic lung resistance	Yes
VCO ₂	ml/min	CO ₂ production	No
Pmin	cmH2O, hPa, mbar	Minimum airway pressure	No
P0.1	cmH2O, hPa, mbar	100 ms occlusion pressure	No
Pmean	cmH2O, hPa, mbar	Mean pressure	Yes
Pplat	cmH2O, hPa, mbar	Plateau pressure	Yes
PEEP	cmH2O, hPa, mbar	Positive end-expiratory pressure	Yes
PEEPi	cmH2O, hPa, mbar	Intrinsic positive end-expiratory pressure	Yes
fmand	/min	Mandatory breathing frequency	Yes
Ppeak	cmH2O, hPa, mbar	Peak pressure	Yes
Vtrap	ml	Volume trapped in the lung by intrinsic PEEP, and not exhaled during subsequent expiration	No
TVe spn	ml	Spontaneous expiratory tidal volume	Yes
Vds	ml	Dead space	No
NIF	cmH2O, hPa, mbar	Negative inspiratory force	No
Mvleak	L/min	Leakage minute volume	Yes
Leak Comp	%	Leak compensation	No
fspn	/min	Spontaneous respiratory rate	Yes
MV	L/min	Minute volume	Yes
RSBI	1/(min.L)	Rapid shallow breathing index	Yes
ftotal	/min	Total respiratory rate	Yes
EtCO ₂	%,kPa,mmHg	End-tidal carbon dioxide	Yes
I:E	\	Inspiratory time:Expiratory time ratio	Yes
FiO ₂	%,kPa,mmHg	Fractional concentration of O ₂ in inspired gas	Yes
MVe	L/min	Expiratory minute volume	Yes

Monitor output: parameters from Draeger Evita V300 ventilator			
Labels	Units	Description	Trend, record, print
MVi	L/min	Inspiratory minute volume	Yes
TVe	ml	Expiratory tidal volume	Yes
TVi	ml	Inspired tidal volume	Yes
TVe/IBW	ml/kg	TVe/IBW	Yes
VTCO ₂	ml	CO ₂ tidal elimination	No
EtCO ₂ %	%	End-tidal carbon dioxide	Yes
FiO ₂ %	%	Fractional concentration of O ₂ in inspired gas	Yes
Setting Parameters			
O ₂ %	%	Oxygen concentration	No
Flow	L/min	Flow	No
T _{insp}	sec	Time of inspiration	No
f	/min	Breath rate	No
PEEP	cmH ₂ O, hPa, mbar	Positive end-expiratory pressure	No
Δ _{int} PEEP	cmH ₂ O, hPa, mbar	Intermittent PEEP	No
P _{low}	cmH ₂ O, hPa, mbar	Lower pressure level	No
P _{high}	cmH ₂ O, hPa, mbar	Upper pressure level	No
T _{low}	sec	Time for the lower pressure level	No
T _{high}	sec	Time for the upper pressure level	No
Apnea T _{insp}	sec	Apnea time	No
ΔP _{supp}	cmH ₂ O, hPa, mbar	Pressure support level	No
P _{max}	cmH ₂ O, hPa, mbar	Maximum airway pressure	No
F- Trig	L/min	Inspiratory trigger level (flow trigger)	No
T _{slope}	sec	Rise time	No
Flow Assist	cmH ₂ O.s/L,hPa.s/ L,mbar.s/L	Flow assist	No
Vol Assist	cmH ₂ O/L,hPa/ L,mbar/L	Volume assist	No

Monitor output: parameters from Draeger Evita V300 ventilator			
Labels	Units	Description	Trend, record, print
fapnea	/min	Breath rate for apnea ventilation	No
Pinsp	cmH2O, hPa, mbar	Pressure control level of inspiration	No
ATC	%	Automatic Tube Compensation	No
Tube ID	mm	Tube ID	No
Tdisconnect	sec	Delay time for "Airway pressure lower alarm limit"	No
Ti max	sec	Maximum inspiration time	No
TV	ml	Tidal volume	No
TVapnea	ml	Apnea tidal volume	No
Exp%	%	Inspiration termination level	No
Trigger	%	Trigger	No
I:E	\	Inspiratory time: Expiratory time ratio	No

4.9.2 Output Signals - Alarms

Monitor output: alarms from Draeger Evita V300 ventilator		
Mindray Patient Monitor		Evita V300 Alarm
Priority	Label	Label
Physiological alarms		
High	FiO ₂ Low	FIO2 LOW
High	FiO ₂ High	O2 HIGH
High	Paw High	Airway pressure high
High	Paw Low	PAW LOW
High	MV High	MIN VOL HIGH
High	MV Low	MIN VOL LOW
High	Apnea	APNEA RESP
High	PEEP High	PEEP HIGH

Monitor output: alarms from Draeger Evita V300 ventilator		
Mindray Patient Monitor		Evita V300 Alarm
Priority	Label	Label
High	PEEP Low	PEEP LOW
High	Apnea Ventilation	APNEA VENT
High	TV Not Achieved	TIDAL VOL LO
Medium	EtCO ₂ Low	ETCO2 LOW
Medium	EtCO ₂ High	ETCO2 HIGH
Medium	VOL INCONST	VOL INCONST
Medium	RR High	RESP RATE HI
Medium	TVe High	TIDAL VOL HI
Technical alarms		
High	Air Supply Pressure Low	AIR SUPPLY
High	O ₂ Supply Pressure Low	LOW O2 SUPPLY
High	Check Flow Sensors	FLOW SENSOR EXP TIME ERR
High	CLEAN CO ₂	CLEAN CO2
High	Negative Airway Pressure	PAW NEGATIVE
High	EXP-VALVE?	EXP-VALVE
High	No O ₂ Pressure	NO OXYGEN
High	Circuit Disconnect	DISCONNECT
High	Neo Flow Sensor Error	NEO FLOW
High	Airway Obstructed?	TUBE OBSTRUC
High	Power Failure	POWER ERR

Monitor output: alarms from Draeger Evita V300 ventilator		
Mindray Patient Monitor		Evita V300 Alarm
Priority	Label	Label
High	High Technical Alarm	<p>If the monitor shows the alarm [High Technical alarms], the external device may have the following alarms:</p> <p>CO₂ NOT CAL BATTERY ERR SPEAKER FAIL EVITA ERR % O₂ ERR VOL CAL VOL ERR PRESS ERR AW-TEMP INOP COOLING INT.TMP.HIGH CO₂ SENSOR AIR PRESS HI HI O₂ SUPPLY SYSTEM FAUL LOSS OF DATA HOSE ERROR SC ABORTED SC INOP</p>
High	High Technical Alarm	<p>CENTRAL HYPO PERS TACHYP UNEXPL HYPER</p>
Medium	Medium Technical Alarm	<p>If the monitor shows the alarm [Medium Technical alarms], the external device may have the following alarms:</p> <p>GAS FAILURE NO AIR AMB PRESS CHECK EVITA NEBULIZ. OFF BATT. LOW</p>
Low	Battery in Use	BATTERY ON

Monitor output: alarms from Draeger Evita V300 ventilator		
Mindray Patient Monitor		Evita V300 Alarm
Priority	Label	Label
Low	Low Technical Alarm	If the monitor shows the alarm [Low Technical alarms], the external device may have the following alarms: EXPHOLD END PMIN REACHED PLOW LOW PLOW HIGH CO2 ERR

4.9.3 Output Signals - Waveforms (For BeneVision N series Monitors)

Label	Units
Paw	cmH2O, mbar, hpa
Flow	L/min
Vol	mL
CO2	mmHg, kPa,%

4.10 Draeger Evita V600/Evita V800/Infinity V500

NOTE

- Only the Benevision N Series monitor supports integration with the Draeger Evita V600/Evita V800 ventilator.

4.10.1 Output Signals - Parameters

Monitor output: parameters from Draeger Evita V600/Evita V800/Infinity V500 ventilator			
Labels	Units	Description	Trend, record, print
Monitoring Parameters			

Monitor output: parameters from Draeger Evita V600/Evita V800/Infinity V500 ventilator			
Labels	Units	Description	Trend, record, print
Cdyn	ml/cmH2O,ml/hPa,ml/mbar	Dynamic compliance	Yes
Rdyn	cmH2O/L/s,hPa/L/s,mbar/L/s	Dynamic lung resistance	Yes
VCO ₂	ml/min	CO ₂ production	No
Pmin	cmH2O, hPa, mbar	Minimum airway pressure	No
P0.1	cmH2O, hPa, mbar	100 ms occlusion pressure	No
Pmean	cmH2O, hPa, mbar	Mean pressure	Yes
Pplat	cmH2O, hPa, mbar	Plateau pressure	Yes
PEEP	cmH2O, hPa, mbar	Positive end-expiratory pressure	Yes
PEEPi	cmH2O, hPa, mbar	Intrinsic positive end-expiratory pressure	Yes
fmand	/min	Mandatory breathing frequency	Yes
Ppeak	cmH2O, hPa, mbar	Peak pressure	Yes
Vtrap	ml	Volume trapped in the lung by intrinsic PEEP, and not exhaled during subsequent expiration	No
TVe spn	ml	Spontaneous expiratory tidal volume	Yes
Vds	ml	Dead space	No
NIF	cmH2O, hPa, mbar	Negative inspiratory force	No
Mvleak	L/min	Leakage minute volume	Yes
Leak Comp	%	Leak compensation	No
fspn	/min	Spontaneous respiratory rate	Yes
MV	L/min	Minute volume	Yes
RSBI	1/(min.L)	Rapid shallow breathing index	Yes
ftotal	/min	Total respiratory rate	Yes
EtCO ₂	%,kPa,mmHg	End-tidal carbon dioxide	Yes
EtCO ₂ %	%	End-tidal carbon dioxide	Yes
FiO ₂	%,kPa,mmHg	Fractional concentration of O ₂ in inspired gas	Yes

Monitor output: parameters from Draeger Evita V600/Evita V800/Infinity V500 ventilator			
Labels	Units	Description	Trend, record, print
FiO2%	%	Fractional concentration of O ₂ in inspired gas	Yes
TVe	ml	Expiratory tidal volume	Yes
TVi	ml	Inspired tidal volume	Yes
MVe	L/min	Expiratory minute volume	Yes
MVi	L/min	Inspiratory minute volume	Yes
VT _{CO₂}	ml	CO ₂ tidal elimination	No
I:E	\	Inspiratory time:Expiratory time ratio	Yes
Cstat	ml/cmH ₂ O,ml/hPa,ml/mbar	Static compliance	Yes
TVe/IBW	ml/kg	TVe/IBW	Yes
MV _{spn} %	%	Spontaneous breathing portion of minute volume	Yes
Setting Parameters			
O ₂ %	%	Oxygen concentration	No
Flow	sec	Flow	No
T _{insp}	sec	Time of inspiration	No
I:E	\	Inspiratory time:Expiratory time ratio	No
f	/min	Breath rate	No
PEEP	cmH ₂ O, hPa, mbar	Positive end-expiratory pressure	No
Δ _{int} PEEP	cmH ₂ O, hPa, mbar	Intermittent PEEP	No
P _{low}	cmH ₂ O, hPa, mbar	Lower pressure level	No
P _{high}	cmH ₂ O, hPa, mbar	Upper pressure level	No
T _{low}	sec	Time for the lower pressure level	No
T _{high}	sec	Time for the upper pressure level	No

Monitor output: parameters from Draeger Evita V600/Evita V800/Infinity V500 ventilator			
Labels	Units	Description	Trend, record, print
Apnea T _{insp}	sec	Apnea time	No
ΔP _{supp}	cmH ₂ O, hPa, mbar	Pressure support level	No
P _{max}	cmH ₂ O, hPa, mbar	Maximum airway pressure	No
F-Trig	L/min	Inspiratory trigger level (flow trigger)	No
T _{slope}	sec	Rise time	No
Flow Assist	cmH ₂ O.s/L, hPa.s/L, mbar.s/L	Flow assist	No
Vol Assist	cmH ₂ O/L, hPa/L, mbar/L	Volume assist	No
TV	ml	Tidal volume	No
f _{apnea}	/min	Breath rate for apnea ventilation	No
P _{insp}	cmH ₂ O, hPa, mbar	Pressure control level of inspiration	No
ATC	%	Automatic tube compensation	No
Tube ID	mm	Tube ID	No
T _{disconnect}	sec	Delay time for "Airway pressure lower alarm limit"	No
T _{i max}	sec	Maximum inspiration time	No
TV _{apnea}	ml	Apnea tidal volume	No
Trigger	%	Trigger	No
Exp%	%	Inspiration termination level	No

4.10.2 Output Signals - Alarms

Monitor output: alarms from Draeger Evita V600/Evita V800/Infinity V500 ventilator		
Mindray Patient Monitor		Evita V600/Evita V800/Infinity V500 Alarm
Priority	Label	Label
Physiological alarms		

Monitor output: alarms from Draeger Evita V600/Evita V800/Infinity V500 ventilator		
Mindray Patient Monitor		Evita V600/Evita V800/Infinity V500 Alarm
Priority	Label	Label
High	FiO ₂ Low	FiO2 low
High	Paw High	Airway pressure high
High	MV Low	MV low
High	MV High	MV high
High	FiO ₂ High	FiO2 high
High	Apnea	APNEA RESP
High	Paw Low	Airway pressure low
High	PEEP High	PEEP high
High	PEEP Low	PEEP low
High	Apnea ventilation	Apnea ventilation
Medium	EtCO ₂ Low	etCO2 low
Medium	EtCO ₂ High	etCO2 high
Medium	RR High	High respiratory rate
Medium	TVe High	Tidal volume high
Medium	TVe Low	Tidal volume low
Medium	VOL INCONST	VT not reached
Technical alarms		
High	Air Supply Pressure Low	Air supply down
High	O ₂ Supply Pressure Low	O2 supply down
High	CLEAN CO ₂	Clean CO2 cuvette
High	Power Failure	Internal power supply failure
High	Check Flow Sensors	Flow sensor failure
High	EXP-VALVE?	Expiratory valve malfunction
High	Negative Airway Pressure	Airway pressure negative
High	Neo Flow Sensor Error	Neo. flow sensor changed ?
High	Circuit Disconnect	Disconnection Ventilator
High	No O ₂ Pressure	O2 supply down

Monitor output: alarms from Draeger Evita V600/Evita V800/Infinity V500 ventilator		
Mindray Patient Monitor		Evita V600/Evita V800/Infinity V500 Alarm
Priority	Label	Label
High	AirWay Obstructed	Tube Obstruct
High	High Technical Alarm	<p>If the monitor shows the alarm [High Technical alarms], the external device may have the following alarms:</p> <p>CO₂ NOT CAL BATTERY ERR SPEAKER FAIL VENT ERR VOL ERR AW TEMP INOP AIR PRESS HI HI O2 SUPPLY SYSTEM FAULT BATTER ERR COOLING LOSS OF DATA HOSE ERR O2 Error Press Err AW TEMP Sens INT TEM HIGH Evita Err</p>
Medium	Medium Technical Alarm	<p>If the monitor shows the alarm [Medium Technical alarms], the external device may have the following alarms:</p> <p>Air supply down Nebulization finished Ambient pressure sensor? Device check incomplete GAS FAILURE BATT LOW</p>
Low	Battery in Use	Internal battery activated

Monitor output: alarms from Draeger Evita V600/Evita V800/Infinity V500 ventilator		
Mindray Patient Monitor		Evita V600/Evita V800/Infinity V500 Alarm
Priority	Label	Label
Low	Low Technical Alarm	If the monitor shows the alarm [Low Technical alarms], the external device may have the following alarms: Exp. hold interrupted CO ₂ measurement failed Plow>high limit Plow<low limit PMIN REACHED CO2 Err VOL CAL

4.10.3 Output Signals - Waveforms (For BeneVision N series Monitors)

Label	Units
Paw	cmH ₂ O, mbar, hpa
Flow	L/min
Vol	mL
CO ₂	mmHg, kPa, %

4.11 Draeger Savina 300

4.11.1 Output Signals - Parameters

Monitor output: parameters from Draeger Savina 300 ventilator			
Labels	Units	Description	Trend, record, print
Monitoring Parameters			
Cdyn	ml/cmH ₂ O,ml/hPa,ml/mbar	Dynamic compliance	Yes
Rdyn	cmH ₂ O/L/s,hPa/L/s,mbar/L/s	Dynamic lung resistance	Yes

Monitor output: parameters from Draeger Savina 300 ventilator			
Labels	Units	Description	Trend, record, print
Pmean	cmH2O, hPa, mbar	Mean pressure	Yes
PEEP	cmH2O, hPa, mbar	Positive end-expiratory pressure	Yes
Ppeak	cmH2O, hPa, mbar	Peak pressure	Yes
TVe	ml	Expiratory tidal volume	Yes
TVi	ml	Inspired tidal volume	Yes
MV	L/min	Minute volume	Yes
ftotal	/min	Total respiratory rate	Yes
MVspn	L/min	Spontaneous breathed minute volume	Yes
fspn	/min	Spontaneous respiratory rate	Yes
FiO ₂	%,kPa,mmHg	Fractional concentration of O ₂ in inspired gas	Yes
T	°C, °F	Inspiratory breathing gas temperature	No
EtCO ₂	%,kPa,mmHg	End-tidal carbon dioxide	Yes
RSBI	1/(min.L)	Rapid shallow breathing index	Yes
Pplat	cmH2O, hPa, mbar	Plateau pressure	Yes
I:E	\	Inspiratory time: Expiratory time ratio	Yes
EtCO ₂ %	%	End-tidal carbon dioxide	Yes
FiO ₂ %	%	Fractional concentration of O ₂ in inspired gas	Yes
Setting Parameters			
O ₂ %	%	Oxygen concentration	No
TV	ml	Tidal volume	No
TVapnea	ml	Apnea tidal volume	No
fapnea	/min	Breath rate for apnea ventilation	No
f	/min	Breath rate	No
I:E	\	Inspiratory time: Expiratory time ratio	No

Monitor output: parameters from Draeger Savina 300 ventilator			
Labels	Units	Description	Trend, record, print
Δint.PEEP	cmH2O, hPa, mbar	Intermittent PEEP	No
F-Trig	L/min	Inspiratory trigger level (flow trigger)	No
Apnea T _{insp}	sec	Apnea Time	No
PASB	cmH2O, hPa, mbar	Assisted spontaneous breathing	No
P _{insp}	cmH2O, hPa, mbar	Pressure control level of inspiration	No
P _{max}	cmH2O, hPa, mbar	Maximum airway pressure	No
T _{disconnect}	sec	Delay time for "Airway pressure lower alarm limit"	No
FlowACC	cmH2O/s, hPa/s, mbar/s	Flow acceleration	No
P _{low}	cmH2O, hPa, mbar	Lower pressure level	No
P _{high}	cmH2O, hPa, mbar	Upper pressure level	No
T _{high}	sec	Time for the upper pressure level	No
T _{low}	sec	Time for the lower pressure level	No
T _{insp}	sec	Time of inspiration	No
PEEP	cmH2O, hPa, mbar	Positive end-expiratory pressure	No

4.11.2 Output Signals - Alarms

Monitor output: alarms from Draeger Savina 300 ventilator		
Mindray Patient Monitor		Savina 300 Alarm
Priority	Label	Label
Physiological alarms		
High	Paw High	Air pressure high
High	Paw Low	Air pressure low
High	MV High	MV high

Monitor output: alarms from Draeger Savina 300 ventilator		
Mindray Patient Monitor		Savina 300 Alarm
Priority	Label	Label
High	MV Low	MV low
High	FiO ₂ High	O2 HIGH
High	FiO ₂ Low	O2 low
High	PEEP High	PEEP HIGH
High	ASB>4s	Assist Spontaneous Breathing>4s
High	Apnea Ventilation	Apnea ventilation
High	Apnea	APNEA SAVINA
High	AW-TEMP HIGH	Airway temperature high
Medium	TVe High	Tidal volume high
Medium	TVe Low	Tidal volume low
Medium	RR High	RESP RATE HI
Medium	EtCO ₂ Low	EtCO2 low
Medium	EtCO ₂ High	EtCO2 high
Technical alarms		
High	O ₂ Supply Pressure Low	O2 supply pressure low
High	Check Flow Sensors	Check flow sensor
High	EXP-VALVE?	Check expiratory valve?

Monitor output: alarms from Draeger Savina 300 ventilator		
Mindray Patient Monitor		Savina 300 Alarm
Priority	Label	Label
High	High Technical Alarm	<p>If the monitor shows the alarm [High Technical alarms], the external device may have the following alarms:</p> <ul style="list-style-type: none"> High O₂ supply pressure insp.O₂ measurement in operation Failen to cycle Problem with fan Problem with PEEP control volume measurement inoperable Pressure measurement inoperable CO₂ not calibrated COOLING SAVINA ERR BATTERY ERR AW TEMP INOP
Medium	Medium Technical Alarm	<p>If the monitor shows the alarm [Medium Technical alarms], the external device may have the following alarms:</p> <ul style="list-style-type: none"> Check cooling CHECK SAVINA 300 NO nubelizer SAVINA STDBY BATTERY LOW MICROFILTER
Low	Low Technical Alarm	<p>If the monitor shows the alarm [Low Technical alarms], the external device may have the following alarms:</p> <ul style="list-style-type: none"> Insp hold aborted CO₂ device failure CO₂ sensor disconnected Expiration hold aborted

4.12 Draeger Oxylog 3000 plus

4.12.1 Output Signals - Parameters

Monitor output: parameters from Draeger Oxylog 3000 plus ventilator			
Labels	Units	Description	Trend, record, print
Monitoring Parameters			
Pmean	cmH2O, hPa, mbar	Mean airway pressure	Yes
Pplat	cmH2O, hPa, mbar	Plateau pressure	Yes
PEEP	cmH2O, hPa, mbar	Positive end-expiratory pressure	Yes
Ppeak	cmH2O, hPa, mbar	Peak inspiratory pressure	Yes
TV	ml	Tidal volume	Yes
fspn	/ml	Spontaneous respiratory rate	Yes
MVspn	L/min	Spontaneous minute volume	Yes
MV	L/min	Minute volume	Yes
f	/ml	Respiratory rate	Yes
EtCO2%	%	End-tidal CO2 concentration	Yes
FiO2%	%	Inspiratory oxygen fraction	Yes
Setting Parameters			
FiO2%	%	Inspiratory oxygen fraction	No
Tvi	ml	Inspiratory tidal volume	No
Tinsp	sec	Inspiratory time	No
f	/ml	Breath rate for apneaventilation	No
PEEP	cmH2O, hPa, mbar	Positive end-expiratory pressure	No
Apnea Tinsp	sec	Apnea alarm time	No
ΔPsupp	cmH2O, hPa, mbar	Pressure limitation	No
Pmax	cmH2O, hPa, mbar	Inspiratory trigger level(flow trigger)	No

Monitor output: parameters from Draeger Oxylog 3000 plus ventilator			
Labels	Units	Description	Trend, record, print
Tplat	sec	Plateau time in % of inspiratory time	No
F-Trig	L/min	Flow trigger threshold	No
Tslope	sec	Pressure rise time	No
fapnea	/min	Respiratory rate for apnea ventilation	No
Tvapnea	ml	Tidal volume for apnea ventilation	No
Pinsp	cmH2O, hPa, mbar	Inspiratory pressure	No
I:E	\	Ratio of inspiration to expiration	No
Exp%	%	Inspiratory termination criterion based on peak inspiratory flow	No

4.12.2 Output Signals - Alarms

Monitor output: alarms from Draeger Oxylog 3000 plus ventilator		
Mindray Patient Monitor		Draeger Oxylog 3000 plus
Priority	Label	Label
Physiological alarms		
High	Apnea	Apnea
High	FiO2 Low	FiO2 Low
High	Paw High	Paw high
High	Paw Low	Paw low
High	MV Low	MVe low
High	MV High	MVe high
High	High Paw Sustained	Continuous high Pressure
High	Apnea Ventilation	Apnea ventilation

Monitor output: alarms from Draeger Oxylog 3000 plus ventilator		
Mindray Patient Monitor		Draeger Oxylog 3000 plus
Priority	Label	Label
Medium	EtCO2 Low	etCO2 low
Medium	EtCO2 High	etCO2 high
Medium	RR High	High respiratory rate
Technical alarms		
High	O2 and Air Supply	Supply pressure low
High	CLEAN CO2	Clean the CO2 cuvette
High	Circuit Leak	Leakage
High	Check Flow Sensors	Check settings time
High	High Technical Alarm	If the monitor shows the alarm [High Technical alarms], the external device may have the following alarms: CO2 Zero calib. request Problems with respirator Paw measurement inop Only 100 % O2 to patient CO2 Zero calib. failed CO2 Filter check failed No int. battery charging
Medium	Prompt	Check Measuring lines
Medium	VT low	VT low, pressure limit
Medium	Medium Technical Alarm	If the monitor shows the alarm [Medium Technical alarms], the external device may have the following alarms: Charge int. battery CO2 sensor? Check setting flow Int. battery discharged Settings not confirmed Set tidal volume too high for connected hose VT high for hose

Monitor output: alarms from Draeger Oxylog 3000 plus ventilator		
Mindray Patient Monitor		Draeger Oxylog 3000 plus
Priority	Label	Label
Low	Low Technical Alarm	If the monitor shows the alarm [Low Technical alarms], the external device may have the following alarms: Speaker failure CO ₂ device failure Gas mixer inoperabl Inspiratory flow measurement inoperable Confirm settings

4.12.3 Output Signals - Waveforms (For BeneVision N series Monitors)

Label	Units
Paw	cmH2O, mbar, hpa
Flow	L/min
CO2	mmHg, kPa,%

4.13 GE Carescape R860

4.13.1 Output Signals - Parameters

Monitor output: parameters from GE Carescape R860 ventilator			
Labels	Units	Description	Trend, record, print
Monitoring Parameters			
Ppeak	cmH2O, hPa, mbar	Peak pressure	Yes
Pplat	cmH2O, hPa, mbar	Plateau pressure	Yes
Pmean	cmH2O, hPa, mbar	Mean pressure	Yes
TVe	ml	Expiratory tidal volume	Yes
TVi	ml	Inspired tidal volume	Yes
TVe/IBW	ml/kg	TVe/IBW	Yes

Monitor output: parameters from GE Carescape R860 ventilator			
Labels	Units	Description	Trend, record, print
TVe spn	ml	Spontaneous expiratory tidal volume	Yes
MVspn	L/min	Spontaneous breathed minute volume	Yes
MVe	L/min	Expiratory minute volume	Yes
MVi	L/min	Inspiratory minute volume	Yes
fmand	/min	Mandatory breathing frequency	Yes
fspn	/min	Spontaneous respiratory rate	Yes
I:E	\	Inspiratory time:Expiratory time ratio	Yes
FiO ₂	%,kPa,mmHg	Fractional concentration of O ₂ in inspired gas	Yes
EtO ₂	%,kPa,mmHg	End-tidal O ₂	Yes
ΔO ₂	%,kPa,mmHg	Difference between inspiratory and expiratory O ₂	No
Rdyn	cmH ₂ O/L/s,hPa/L/s,mbar/L/s	Dynamic lung resistance	Yes
Cstat	ml/cmH ₂ O,ml/hPa,ml/mbar	Static compliance	Yes
Cdyn	ml/cmH ₂ O,ml/hPa,ml/mbar	Dynamic compliance	Yes
RSBI	1/(min.L)	Rapid shallow breathing index	Yes
Texp	sec	Expiratory time	Yes
Paux Peak	cmH ₂ O, hPa, mbar	Peak auxiliary pressure	No
Paux Mean	cmH ₂ O, hPa, mbar	Mean auxiliary pressure	No
Paux Min	cmH ₂ O, hPa, mbar	Minimum auxiliary pressure	No
PO ₂	kPa	oxygen supply pressure	No
Pair	kPa	air supply pressure	No
PEEPi	cmH ₂ O, hPa, mbar	Intrinsic positive end-expiratory pressure	Yes

Monitor output: parameters from GE Carescape R860 ventilator			
Labels	Units	Description	Trend, record, print
PEEPe	cmH2O, hPa, mbar	Extrinsic positive end-expiratory pressure	No
PEEPtot	cmH2O, hPa, mbar	Total PEEP	Yes
EtCO ₂	%,kPa,mmHg	End-tidal carbon dioxide	Yes
RRCO ₂	bpm	Respiratory rate of CO ₂	Yes
EE	kcal/day	Energy expenditure	No
RQ	\	Respiratory quotient	No
VO ₂	ml/min	Oxygen consumption	Yes
VCO ₂	ml/min	CO ₂ production	No
VO ₂ /m ²	ml/min/m2	Oxygen consumption per body surface area	No
VCO ₂ / m ²	ml/min/m2	CO ₂ consumption per body surface area	No
VO ₂ /kg	ml/min/kg	Oxygen consumption per body weight	No
VCO ₂ /kg	ml/min/kg	CO ₂ consumption per body weight	No
ftotal	/min	Total respiratory rate	Yes
FiO ₂ %	%	Fractional concentration of O ₂ in inspired gas	Yes
EtO ₂ %	%,	End-tidal O ₂	Yes
EtCO ₂ %	%	End-tidal carbon dioxide	Yes
ΔO ₂ %	%	Difference between inspiratory and expiratory O ₂	No
Setting Parameters			
PEEP	cmH2O, hPa, mbar	Positive end-expiratory pressure	No
TV	ml	Tidal volume	No
Base Flow	L/min	Base Flow	No
Tsupp	sec	Support time	No
F-Trig	L/min	Inspiratory trigger level (flow trigger)	No

Monitor output: parameters from GE Carescape R860 ventilator			
Labels	Units	Description	Trend, record, print
P-Trig	cmH2O, hPa, mbar	Inspiratory trigger level (pressure trigger)	No
Δ Psupp	cmH2O, hPa, mbar	Pressure support level	No
Plimit	cmH2O, hPa, mbar	Pressure limit level	No
Tinsp	sec	Time of inspiration	No
Pinsp	cmH2O, hPa, mbar	Pressure control level of inspiration	No
Tslope	sec	Rise time	No
Tpause	sec	Pause Time	No
Phigh	cmH2O, hPa, mbar	Upper pressure level	No
Plow	cmH2O, hPa, mbar	Lower pressure level	No
Thigh	sec	Time for the upper pressure level	No
Tlow	sec	Time for the lower pressure level	No
Pmax	cmH2O, hPa, mbar	Maximum airway pressure	No
Flow	L/min	Flow	No
Apnea Tinsp	sec	Apnea Time	No
Tdisconnect	sec	Delay time for "Airway pressure lower alarm limit"	No
Tube ID	mm	Tube ID	No
O ₂ %	%	Oxygen concentration	No
I:E	\	Inspiratory time:Expiratory time ratio	No

4.13.2 Output Signals - Alarms

Monitor output: alarms from GE Carescape R860 ventilator		
Mindray Patient Monitor		Carescape R860 Alarm
Priority	Label	Label
Physiological alarms		

Monitor output: alarms from GE Carescape R860 ventilator		
Mindray Patient Monitor		Carescape R860 Alarm
Priority	Label	Label
High	Apnea	Apnea
High	AW-TEMP HIGH	Air Temp High
High	FiO ₂ High	FiO2 high
High	FiO ₂ Low	FiO2 low
High	MV High	MVexp high
High	MV Low	MVexp low
High	Ppeak High	Ppeak High
High	Ppeak Low	Ppeak Low
High	Pressure Sustained	Sustained Paw
High	TV Not Achieved	Tidal volume not delivered(VT Not Achieved)
Medium	EtCO ₂ High	EtCO2 High
Medium	EtCO ₂ Low	EtCO2 Low
Medium	EtO ₂ High	EtO2 High
Medium	EtO ₂ Low	EtO2 Low
Medium	Paux High	Paux High
Medium	PEEPe High	PEEPe High
Medium	PEEPe Low	PEEPe Low
Medium	PEEPi High	PEEPi High
Medium	RR High	RR High
Medium	RR Low	RR Low
Medium	TVe High	VTexp high
Medium	TVe Low	VTexp Low
Low	Plimit Reached	Plimit Reached
Technical alarms		
High	Air Supply Pressure Low	Air Supply Pressure Low
High	Airway Obstructed?	Breathing Circuit Occlusion
High	Circuit Leak	Circuit Leak

Monitor output: alarms from GE Carescape R860 ventilator		
Mindray Patient Monitor		Carescape R860 Alarm
Priority	Label	Label
High	Check Flow Sensors	Expiratory Flow Sensor Error Exp Flow Sensor Failure
High	Negative Airway Pressure	Negative Airway Pressure
High	Neo Flow Sensor Error	Neo Flow Sensor Error
High	No Gas Supply Pressure	No Gas Supply Pressure
High	O ₂ Supply Pressure Low	O2 Supply Pressure Low
High	Patient Connection Leak	Patient Connection Leak
High	Patient Connected?	Patient detected (Patient Connected?)
High	Patient Disconnected	Patient Disconnected
High	Power Failure	Power Supply Fail

Monitor output: alarms from GE Carescape R860 ventilator		
Mindray Patient Monitor		Carescape R860 Alarm
Priority	Label	Label
High	High Technical Alarm	<p>If the monitor shows the alarm [High Technical alarms], the external device may have the following alarms:</p> <ul style="list-style-type: none"> Air Supply Pressure High Air Temp Sensor Error Clean Neo Flow Sensor FiO₂ Control Error Relief Valve Opened Low Internal Battery 1 Min Low Internal Battery 5 Min Low Internal Battery 10 Min Mixed Gas Temp Sensor Error Neo Flow Sensor Reversed Neo Flow Sensor Off No D-Lite Sensor? No Expiratory Flow Sensor No Neo Flow Sensor O₂ Supply Pressure High O₂ Temp Sensor ErrorPressure Sensor Failure Primary Audio Failure Relief Valve Failure Replace Neo Flow Sensor Temp High Shutdown Possible Total Flow Sensor Communication Failure Volume Delivery Error
Medium	FiO ₂ Sensor Disconnected	O ₂ Sensor Failure

Monitor output: alarms from GE Carescape R860 ventilator		
Mindray Patient Monitor		Carescape R860 Alarm
Priority	Label	Label
Medium	Medium Technical Alarm	<p>If the monitor shows the alarm [Medium Technical alarms], the external device may have the following alarms:</p> <ul style="list-style-type: none"> Backup Ventilation on Check D-fend Check Sample Gas Out Circuit Leak Alarm Off Fans Require Service Low Internal Battery 20 Min Module Fail No CO₂, O₂ Data No Battery Backup Replace D-fend Sample Flow Deviation Sample Line Blocked SBT Ended No Battery Backup Backup Audio Failure
Low	Battery in Use	Battery in use
Low	Low Technical Alarm	<p>If the monitor shows the alarm [Low Technical alarms], the external device may have the following alarms:</p> <ul style="list-style-type: none"> Air Supply Pressure Sensor Out of Range Alarm Light Failure Alarms Silenced Apnea Alarm Off Cannot Calculate FRC Carrier Board Overheat Case Fan Speed Fail Connect Nebulizer Controls Frozen Need Service CPU Fan Speed Fail CPU Overheat Missed Scheduled FRC Module Not Compatible

Monitor output: alarms from GE Carescape R860 ventilator		
Mindray Patient Monitor		Carescape R860 Alarm
Priority	Label	Label
Low	Low Technical Alarm	<p>If the monitor shows the alarm [Low Technical alarms], the external device may have the following alarms:</p> <ul style="list-style-type: none"> Module Warming Up 2 Min Module Warming Up 5 Min Air Supply Pressure No Patient Effort MVexp Low Alarm Off O₂ Supply Pressure Sensor Out of Range Pinsp Sensor Out of Range Pexp Sensor Out of Range Paux Sensor Out of Range SBT Completed successfully Touchscreen Failure

4.13.3 Output Signals - Waveforms (For BeneVision N series Monitors)

Label	Units
Paw	cmH ₂ O, mbar, hpa
Flow	L/min
Vol	mL
CO ₂	%,kPa,mmHg

4.13.4 Output Signals - Respiratory Loops (For BeneVision N series Monitors)

Label	Units
PV Loop	cmH ₂ O/ml, hPa/ml, mbar/ml
FV Loop	L/min/ml
PF Loop	cmH ₂ O/L/min, hPa/L/min, mbar/L/min

4.14 GE Engström Carestation

4.14.1 Output Signals - Parameters

Monitor output: parameters from GE Engström Carestation ventilator			
Labels	Units	Description	Trend, record, print
Monitoring Parameters			
Ppeak	cmH2O, hPa, mbar	Peak pressure	Yes
Pplat	cmH2O, hPa, mbar	Plateau pressure	Yes
Pmean	cmH2O, hPa, mbar	Mean pressure	Yes
TVe	ml	Expiratory tidal volume	Yes
TVi	ml	Inspired tidal volume	Yes
TVe/IBW	ml/kg	TVe/IBW	Yes
TVe spn	ml	Spontaneous expiratory tidal volume	Yes
MVspn	L/min	Spontaneous breathed minute volume	Yes
MVe	L/min	Expiratory minute volume	Yes
MVi	L/min	Inspiratory minute volume	Yes
f _{total}	/min	Total respiratory rate	Yes
f _{mand}	/min	Mandatory breathing frequency	No
f _{spn}	/min	Spontaneous breathing frequency	Yes
I:E	\	Inspiratory time: Expiratory time ratio	Yes
FiO ₂	%,kPa,mmHg	Fractional concentration of O ₂ in inspired gas	Yes
EtO ₂	%,kPa,mmHg	End-tidal O ₂	Yes
ΔO ₂	%,kPa,mmHg	Difference between inspiratory and expiratory O ₂	No
R _{dyn}	cmH2O/L/s,hPa/L/s,mbar/L/s	Dynamic lung resistance	Yes
C _{stat}	ml/cmH2O,ml/hPa,ml/mbar	Static compliance	Yes

Monitor output: parameters from GE Engström Carestation ventilator			
Labels	Units	Description	Trend, record, print
Cdyn	ml/cmH2O,ml/hPa,ml/mbar	Dynamic compliance	Yes
RSBI	1/(min.L)	Rapid shallow breathing index	Yes
Texp	sec	Expiratory time	Yes
Paux Peak	cmH2O, hPa, mbar	Peak auxiliary pressure	No
Paux Mean	cmH2O, hPa, mbar	Mean auxiliary pressure	No
Paux Min	cmH2O, hPa, mbar	Minimum auxiliary pressure	No
PO ₂	kPa	oxygen supply pressure	No
Pair	kPa	air supply pressure	No
PEEPi	cmH2O, hPa, mbar	Intrinsic positive end-expiratory pressure	Yes
PEEPe	cmH2O, hPa, mbar	Extrinsic positive end-expiratory pressure	No
PEEPtot	cmH2O, hPa, mbar	Total PEEP	Yes
EtCO ₂	%,kPa,mmHg	End-tidal carbon dioxide	Yes
RRCO ₂	bpm	Respiratory rate of CO ₂	Yes
EE	kcal/day	Energy expenditure	No
RQ	\	Respiratory quotient	No
VO ₂	ml/min	Oxygen consumption	Yes
VCO ₂	ml/min	CO ₂ production	No
VO ₂ /m ²	ml/min/m2	Oxygen consumption per body surface area	No
VCO ₂ /m ²	ml/min/m2	CO ₂ consumption per body surface area	No
VO ₂ /kg	ml/min/kg	Oxygen consumption per body weight	No
VCO ₂ /kg	ml/min/kg	CO ₂ consumption per body weight	No
FiO ₂ %	%	Fractional concentration of O ₂ in inspired gas	Yes

Monitor output: parameters from GE Engström Carestation ventilator			
Labels	Units	Description	Trend, record, print
EtO ₂ %	%	End-tidal O ₂	Yes
EtCO ₂ %	%	End-tidal carbon dioxide	Yes
ΔO ₂ %	%	Difference between inspiratory and expiratory O ₂	No
Setting Parameters			
O ₂ %	%	Oxygen concentration	No
PEEP	cmH ₂ O, hPa, mbar	Positive end-expiratory pressure	No
TV	ml	Tidal volume	No
Base Flow	L/min	Base Flow	No
Tsupp	sec	Support time	No
F-Trig	L/min	Inspiratory trigger level (flow trigger)	No
Trigger	%	Trigger	No
P-Trig	cmH ₂ O, hPa, mbar	Inspiratory trigger level (pressure trigger)	No
ΔPsupp	cmH ₂ O, hPa, mbar	Pressure support level	No
Plimit	cmH ₂ O, hPa, mbar	Pressure limit level	No
Tinsp	sec	Time of inspiration	No
Pinsp	cmH ₂ O, hPa, mbar	Pressure control level of inspiration	No
Tslope	sec	Rise time	No
Phigh	cmH ₂ O, hPa, mbar	Upper pressure level	No
Plow	cmH ₂ O, hPa, mbar	Lower pressure level	No
Thigh	sec	Time for the upper pressure level	No
Tlow	sec	Time for the lower pressure level	No
Pmax	cmH ₂ O, hPa, mbar	Maximum airway pressure	No
Flow	L/min	Flow	No
Apnea Tinsp	sec	Apnea time	No

Monitor output: parameters from GE Engström Carestation ventilator			
Labels	Units	Description	Trend, record, print
Tdisconnect	sec	Delay time for "Airway pressure lower alarm limit"	No
Tube ID	mm	Tube ID	No
Tpause	sec	Pause Time	No
I:E	\	Inspiratory time: Expiratory time ratio	

4.14.2 Output Signals - Alarms

Monitor output: alarms from GE Engström Carestation ventilator		
Mindray Patient Monitor		Engström Carestation Alarm
Priority	Label	Label
Physiological alarms		
High	MV High	MVexp High
High	MV Low	MVexp Low
High	Apnea	Apnea
High	FiO ₂ High	FiO ₂ High
High	FiO ₂ Low	FiO ₂ Low
High	Pressure Sustained	Sustained Paw
High	TV not Achieved	TV Not Achieved
High	AW TEMP High	Air Temp High
High	Ppeak High	Ppeak High
High	Ppeak Low	Ppeak Low
Medium	TVe Low	TVexp Low
Medium	RR Low	RR Low
Medium	EtCO ₂ High	EtCO ₂ High
Medium	EtCO ₂ Low	EtCO ₂ Low
Medium	RR High	RR High

Monitor output: alarms from GE Engström Carestation ventilator		
Mindray Patient Monitor		Engström Carestation Alarm
Priority	Label	Label
Medium	EtO ₂ High	EtO ₂ High
Medium	EtO ₂ Low	EtO ₂ Low
Medium	PEEPe High	PEEPe High
Medium	PEEPe Low	PEEPe Low
Medium	PEEPi High	PEEPi High
Medium	TVe High	TVexp High
Medium	Paux High	Paux High
Low	Plimit Reached	Plimit Reached
Low	Base Flow High	Base Flow High
Technical alarms		
High	Air Supply Pressure Low	Air Supply Pressure Low
High	O ₂ Supply Pressure Low	O ₂ Supply Pressure Low
High	No Gas Supply Pressure	No Gas Supply Pressure
High	Airway Obstructed?	Breathing Circuit Occlusion
High	Check Flow Sensors	Exp Flow Sensor Error
High	Neo Flow Sensor Error	Neo Flow Sensor Error
High	Patient Connected?	Patient Connected?
High	Negative Airway Pressure	Negative Airway Pressure
High	Circuit Leak	Circuit Leak
High	Patient Connection Leak	Patient Connection Leak
High	Patient Disconnected	Patient Disconnected

Monitor output: alarms from GE Engström Carestation ventilator		
Mindray Patient Monitor		Engström Carestation Alarm
Priority	Label	Label
High	High Technical Alarm	<p>If the monitor shows the alarm [High Technical alarms], the external device may have the following alarms: temp high shutdown possible</p> <ul style="list-style-type: none"> primary audio failure Neo Flow Sensor Reversed Clean Neo Flow Sensor Replace Neo Flow Sensor Neo Flow Sensor Off No Expiratory Flow Sensor No Neo Flow Sensor Air Supply Pressure High O₂ Supply Pressure High FiO₂ Control Error Volume Delivery Error Air Temp Sensor Error O₂ Temp Sensor Error Mixed Gas Temp Sensor Error Total Flow Sensor Communication Failure No D-Lite Sensor? Pressure Sensor Failure Low Internal Battery 20 Min Low Internal Battery 10 Min Low Internal Battery 5 Min Low Internal Battery 1 Min Relief Valve Failure No Patient Effort
Medium	FiO ₂ Sensor Disconnected	O2 Sensor Failure

Monitor output: alarms from GE Engström Carestation ventilator		
Mindray Patient Monitor		Engström Carestation Alarm
Priority	Label	Label
Medium	Medium Technical Alarm	<p>If the monitor shows the alarm [Medium Technical alarms], the external device may have the following alarms:</p> <ul style="list-style-type: none"> Check Sample Gas Out Replace D-fend Sample Line Blocked Check D-fend Sample Flow Deviation Module Fail No CO₂, O₂ Data No Battery Backup Fans Require Service Backup Mode Active Backup audio failure Display Fans Fail
Low	Battery in Use	On Battery
Low	Low Technical Alarm	<p>If the monitor shows the alarm [Low Technical alarms], the external device may have the following alarms:</p> <ul style="list-style-type: none"> Air Supply Pressure Sensor Out of Range O₂ Supply Pressure Sensor Out of Range Pinsp Sensor Out of Range Pexp Sensor Out of Range Paux Sensor Out of Range Module Not Compatible Controls Frozen Need Service Connect Nebulizer SBT Ends < 2 Minutes SBT Completed SBT Ended Cannot Calculate FRC Missed Scheduled FRC FRC Series Stopped Relief Valve Opened

Monitor output: alarms from GE Engström Carestation ventilator		
Mindray Patient Monitor		Engström Carestation Alarm
Priority	Label	Label
Low	Low Technical Alarm	Circuit Leak Alarm Off Apnea Alarm Off MVexp Low Alarm Off Unable to Deliver TV VO ₂ /VCO ₂ /CO ₂ /O ₂ Out of Range No VO ₂ FI _O ₂ > 85% Artifact Module Warming Up 2 Min Module Warming Up 5 Min Alarms Silenced.

4.15 Hamilton C1/C1 NEO/C2/C3/C6/C6S/T1(Polling Protocol)

NOTE

- Only the Benevision N Series monitor supports integration with the Hamilton C1/C1 NEO/C6/C6S/T1 ventilator.

4.15.1 Output Signals - Parameters

Monitor output: parameters from Hamilton C1/C1 NEO/C2/C3/C6/C6S/T1 ventilator			
Labels	Units	Description	Trend, record, print
Monitoring Parameters			
O ₂ %	%	Oxygen concentration	Yes
MV	L/min	Minute volume	Yes
I: E	\	Inspiratory time:Expiratory time ratio	Yes
EtCO ₂	%,kPa,mmHg	End-tidal carbon dioxide	Yes
TVi	ml	Inspired tidal volume	Yes
TVe	ml	Expiratory tidal volume	Yes

Monitor output: parameters from Hamilton C1/C1 NEO/C2/C3/C6/C6S/T1 ventilator			
Labels	Units	Description	Trend, record, print
f _{total}	/min	Total respiratory rate	Yes
f _{spn}	/min	Spontaneous respiratory rate	Yes
P _{peak}	cmH ₂ O, hPa, mbar	Peak pressure	Yes
P _{mean}	cmH ₂ O, hPa, mbar	Mean pressure	Yes
P _{plat}	cmH ₂ O, hPa, mbar	Plateau pressure	Yes
T _{exp}	sec	Expiratory time	Yes
R _i	cmH ₂ O/L/s, hPa/L/s, mbar/L/s	Inspiratory resistance	Yes
C _{stat}	ml/cmH ₂ O, ml/hPa, ml/mbar	Static compliance	Yes
Insp Flow	L/min	Inspiration flow	No
T _{Ve spn}	ml	Spontaneous expiratory tidal volume	Yes
PEEP _i	cmH ₂ O, hPa, mbar	Intrinsic positive end-expiratory pressure	Yes
P _{0.1}	cmH ₂ O, hPa, mbar	100 ms occlusion pressure	No
Exp Flow	L/min	Expiratory flow	No
R _{Cexp}	sec	Expiratory time constant	Yes
PTP	cmH ₂ O.s, hPa.s, mbar.s	Pressure time product	No
PEEP	cmH ₂ O, hPa, mbar	Positive end-expiratory pressure	Yes
Setting Parameters			
f _{CMV}	/min	CMV frequency	No
f _{simv}	/min	Frequency of SIMV	No
TV	ml	Tidal volume	No
PEEP/CPAP	cmH ₂ O, hPa, mbar	PEEP/CPAP	No
ΔP _{supp}	cmH ₂ O, hPa, mbar	Pressure support level	No
O ₂ %	%	Oxygen concentration	No
MV	L/min	Minute volume	No

Monitor output: parameters from Hamilton C1/C1 NEO/C2/C3/C6/C6S/T1 ventilator			
Labels	Units	Description	Trend, record, print
Phigh	cmH2O, hPa, mbar	Upper pressure level	No
I: E	\	Inspiratory time:Expiratory time ratio	No
Exp%	%	Inspiration termination level	No
Ramp	msec	Ramp	No
IBW	kg	Ideal body weight	No
%MinVol	%	Percentage of minute volume to be delivered	No

4.15.2 Output Signals - Alarms

Monitor output: alarms from Hamilton C1/C1 NEO/C2/C3/C6/C6S/T1 ventilator		
Mindray Patient Monitor		C1/C1 NEO/C2/C3/C6/C6S/T1 Alarm
Priority	Label	Label
Physiological alarms		
High	Paw High	High Pressue
High	Apnea	Apnea
High	Loss of PEEP	Loss of PEEP
High	MV Low	Low Min Vol
High	MV High	High Min Vol
Medium	RR High	High Rate
Technical alarms		
High	Disconnection ventilator side	Disconnection Ventilator
High	Patient Disconnected	Disconnection Patient
High	High Technical alarms	If the monitor shows the alarm [High Technical alarms], the external device may have the alarm: Oxygen Concentration.

Monitor output: alarms from Hamilton C1/C1 NEO/C2/C3/C6/C6S/T1 ventilator		
Mindray Patient Monitor		C1/C1 NEO/C2/C3/C6/C6S/T1 Alarm
Priority	Label	Label
Medium	Medium Technical alarms	If the monitor shows the alarm [Medium Technical alarms], the external device may have the alarm: Gas Supply Spez Alarm
Low	Low Technical alarms	If the monitor shows the alarm [Low Technical alarms], the external device may have the following alarms: Operator General Alarm

4.16 Hamilton C1/C6 (Block Protocol) (for BeneVision N series Monitors)

4.16.1 Output Signals - Parameters

Monitor output: parameters from Hamilton C6 ventilator (Block protocol)			
Labels	Units	Description	Trend, record, print
Monitoring Parameters			
MV	L/min	Minute volume	Yes
Ppeak	cmH2O, hPa, mbar	Peak pressure	Yes
Pplat	cmH2O, hPa, mbar	Plateau pressure	Yes
Pmean	cmH2O, hPa, mbar	Mean pressure	Yes
PEEP	cmH2O, hPa, mbar	Positive end-expiratory pressure	Yes
Pmin	cmH2O, hPa, mbar	Minimum airway pressure	No
PEEPi	cmH2O, hPa, mbar	Intrinsic positive end-expiratory pressure	Yes
P0.1	cmH2O, hPa, mbar	100 ms occlusion pressure	No
PTP	cmH2O.s,hPa.s,mb a.s	Pressure time product	No
Insp Flow	L/min	Inspiration flow	No

Monitor output: parameters from Hamilton C6 ventilator (Block protocol)			
Labels	Units	Description	Trend, record, print
Exp Flow	L/min	Expiratory flow	No
TVi	ml	Inspired tidal volume	Yes
TVe	ml	Expiratory tidal volume	Yes
TVe spn	ml	Spontaneous expiratory tidal volume	Yes
MVspn	L/min	Spontaneous breathed minute volume	Yes
ftotal	/min	Total respiratory rate	Yes
fspn	/min	Spontaneous respiratory rate	Yes
Texp	sec	Expiratory time	Yes
I:E	\	Inspiratory time:Expiratory time ratio	Yes
Ri	cmH2O/L/s,hPa/L/s,mbar/L/s	Inspiratory resistance	Yes
Re	cmH2O/L/s,hPa/L/s,mbar/L/s	Expiratory resistance	Yes
Cstat	ml/cmH2O,ml/hPa,ml/mbar	Static compliance	Yes
RCexp	sec	Expiratory time constant	Yes
RCinsp	sec	Inspiratory time constant	No
RSBI	1/(min.L)	Rapid shallow breathing index	Yes
O ₂ %	%	Oxygen concentration	Yes
WOB	J/L	Work of breathing	Yes
EtCO ₂	%,kPa,mmHg	End-tidal carbon dioxide	Yes
VCO ₂	ml/min	CO ₂ production	No
PR	/min	Pulse rate	Yes
SpO ₂	%	Arterial oxygen saturation from pulse oximetry	Yes
TVe/IBW	ml/kg	TVe/IBW	Yes
Setting Parameters			
f	/min	Breath rate	No

Monitor output: parameters from Hamilton C6 ventilator (Block protocol)			
Labels	Units	Description	Trend, record, print
TV	ml	Tidal volume	No
TPause	%	Pause Time%	No
P-Trig	cmH2O, hPa, mbar	Inspiratory trigger level (pressure trigger)	No
PEEP/CPAP	cmH2O, hPa, mbar	PEEP/CPAP	No
P _{low}	cmH2O, hPa, mbar	Lower pressure level	No
ΔP _{supp}	cmH2O, hPa, mbar	Pressure support level	No
MV	L/min	Minute volume	No
P _{limit}	cmH2O, hPa, mbar	Pressure limit level	No
P _{insp}	cmH2O, hPa, mbar	Pressure control level of inspiration	No
P _{high}	cmH2O, hPa, mbar	Upper pressure level	No
F-Trig	L/min	Inspiratory trigger level (flow trigger)	No
I:E	\	Inspiratory time:Expiratory time ratio	No
PeakFlow	L/min	Peak flow	No
Exp%	%	Inspiration termination level	No
Ramp	msec	Ramp	No
IBW	kg	Ideal body weight	No
%MinVol	%	Percentage of minute volume to be delivered	No
T _{low}	sec	Time for the lower pressure level	No
T _{high}	sec	Time for the upper pressure level	No
T _{i max}	sec	Maximum inspiration time	No
T _{ip}	sec	Inspiratory pause time	No
Tube ID	mm	Tube ID	No
Base flow	L/min	Base Flow	No
O ₂ %	%	Oxygen concentration	No

4.16.2 Output Signals - Alarms

Monitor output: alarms from Hamilton C6 ventilator (Block protocol)		
Mindray Patient Monitor		Hamilton C6 Alarm
Priority	Label	Label
Physiological alarms		
High	Paw High	High pressure
High	Paw Low	Low pressure
High	PEEP High	High PEEP
High	FiO ₂ High	High oxygen
High	FiO ₂ Low	Low oxygen
High	Apnea	Apnea
High	Apnea Ventilation	Apnea ventilation
High	SpO ₂ Low	Low SpO ₂
High	SpO ₂ High	High SpO ₂
High	PR Low	Low Pulse
High	PR High	High Pulse
High	MV Low	Low minute volume
High	MV High	High minute volume
High	Loss of PEEP	Loss of PEEP
Medium	RR High	High frequency
Medium	RR Low	Low frequency
Medium	EtCO ₂ High	PetCO ₂ High
Medium	EtCO ₂ Low	PetCO ₂ Low
Medium	TVe High	Vt High
Medium	TVe Low	Vt Low
Medium	Inspiratory volume limitation	Inspiratory volume limitation
Medium	Pressure limiting	Pressure limitation
Medium	PI Low	Low PI
Medium	PI High	High PI

Monitor output: alarms from Hamilton C6 ventilator (Block protocol)		
Mindray Patient Monitor		Hamilton C6 Alarm
Priority	Label	Label
Low	Apnea Ventilation Ended	Apnea Ventilation ended
Technical alarms		
High	Patient Disconnected	Disconnection on patient side
High	O ₂ cell disconnect	O2 cell missing
High	O ₂ cell cal. Needed	O2 cell calibration needed
High	Disconnection ventilator side	Disconnection ventilator side
High	O ₂ Supply Pressure Low	Oxygen supply failed
High	Check Flow Sensors	If the monitor shows the alarm [Check Flow Sensors], the external device may have the following alarms: Check flow sensor tubing Check flow sensor
High	High Technical alarms	If the monitor shows the alarm [High Technical alarms], the external device may have the following alarms: Wrong flow sensor Flow sensor calibration needed Check patient interface High pressure during sigh Exhalation obstructed External flow sensor failed Obstruction Check flow sensor for water Vent outlet temperature high Pressure not released Device temperature high Replace O2 sensor Loudspeaker defective Buzzer defective Panel connection lost

Monitor output: alarms from Hamilton C6 ventilator (Block protocol)		
Mindray Patient Monitor		Hamilton C6 Alarm
Priority	Label	Label
High	High Technical alarms	Battery 1: Temperature high Battery 2: Temperature high Battery low Battery power loss Battery communication error Battery 1: Defective Battery 2: Defective Options not found Humidifier error Humidifier water high Humidifier chamber temp high Humidifier Y-piece temp high Humidifier tilt Check humidifier Cuff leak Check IntelliCuff Self test failed No ventilation after power-fail Blower fault Battery totally discharged Unknown part number Technical state failed
Medium	Medium Technical alarms	If the monitor shows the alarm [Medium Technical alarms], the external device may have the following alarms: SpO2: patient disconnected SpO2: probe missing SpO2: light interference SpO2: sensor error SpO2: adapter missing Circuit calibration needed SpO2: poor signal Turn the flow sensor Performance limited by high altitude Ventilation adjustment OFF

Monitor output: alarms from Hamilton C6 ventilator (Block protocol)		
Mindray Patient Monitor		Hamilton C6 Alarm
Priority	Label	Label
Medium	Medium Technical alarms	<p>If the monitor shows the alarm [Medium Technical alarms], the external device may have the following alarms:</p> <ul style="list-style-type: none"> Oxygenation adjustment OFF FiO2 set to 100% due to low SpO2 Oxygen control limit exceeded SBT aborted SBT successfully fulfilled Check flow sensor for water Wrong expiratory valve Aerogen nebulizer disconnected Battery low Fan failure Humidifier water low Humidifier chamber temp low Humidifier Y-piece temp low Humidifier check right tube Humidifier check left tube Humidifier check chamber Check humidifier Cannot turn off IntelliCuff Cuff pressure high Cuff deflated Cuff leak Check IntelliCuff
Medium	Medium Technical alarms	<p>If the monitor shows the alarm [Medium Technical alarms], the external device may have the following alarms:</p> <ul style="list-style-type: none"> Check IntelliCuff state Flow sensor calibration needed Function key not operational Touch not functional

Monitor output: alarms from Hamilton C6 ventilator (Block protocol)		
Mindray Patient Monitor		Hamilton C6 Alarm
Priority	Label	Label
Low	Low Technical alarms	<p>If the monitor shows the alarm [Low Technical alarms], the external device may have the following alarms:</p> <ul style="list-style-type: none"> O2 sensor defective O2 sensor not system compatible CO2 sensor disconnected CO2 sensor defect CO2 sensor over temperature CO2 sensor warmup Check CO2 airway adapter Check CO2 sampling line Apnea ventilation ended IRV ASV: Cannot meet target Pressure limit has changed Suctioning maneuver Ventilation Controller at limit Oxygenation Controller at limit Sensor simulation active Recruitment in progress Maximum leak compensation Blower service required CO2 calibration needed Replace HEPA filter Release valve defective Realtime clock failure Loss of external power Battery 1: Calibration required Battery 2: Calibration required Battery 1: Wrong battery Battery 2: Wrong battery Battery low Battery 1: Replacement required Battery 2: Replacement required

Monitor output: alarms from Hamilton C6 ventilator (Block protocol)		
Mindray Patient Monitor		Hamilton C6 Alarm
Priority	Label	Label
		<p>If the monitor shows the alarm [Low Technical alarms], the external device may have the following alarms:</p> <ul style="list-style-type: none"> Preventive maintenance required Touch not functional Invalid communication board Check hardware compatibility Check humidifier communication Check IntelliCuff communication Check IntelliCuff Language not loaded Settings file error Check settings Panel settings file error Restart device to enable Tests/Calib Remote control active

4.16.3 Output Signals - Waveforms

Label	Units
Paw	cmH2O, mbar, hpa
Flow	L/min
Volume	mL
CO2	mmHg, kPa,%

4.17 Hamilton G5 (Block Protocol)

4.17.1 Output Signals - Parameters

Monitor output: parameters from Hamilton G5 ventilator (Block protocol)			
Labels	Units	Description	Trend, record, print
Monitoring Parameters			

Monitor output: parameters from Hamilton G5 ventilator (Block protocol)			
Labels	Units	Description	Trend, record, print
MV	L/min	Minute volume	Yes
Ppeak	cmH2O, hPa, mbar	Peak pressure	Yes
Pplat	cmH2O, hPa, mbar	Plateau pressure	Yes
Pmean	cmH2O, hPa, mbar	Mean pressure	Yes
PEEP	cmH2O, hPa, mbar	Positive end-expiratory pressure	Yes
Pmin	cmH2O, hPa, mbar	Minimum airway pressure	No
PEEPi	cmH2O, hPa, mbar	Intrinsic positive end-expiratory pressure	Yes
P0.1	cmH2O, hPa, mbar	100 ms occlusion pressure	No
PTP	cmH2O.s,hPa.s,mb a.s	Pressure time product	No
Insp Flow	L/min	Inspiration flow	No
Exp Flow	L/min	Expiratory flow	No
TVi	ml	Inspired tidal volume	Yes
TVe	ml	Expiratory tidal volume	Yes
TVe spn	ml	Spontaneous expiratory tidal volume	Yes
MVspn	L/min	Spontaneous breathed minute volume	Yes
ftotal	/min	Total respiratory rate	Yes
fspn	/min	Spontaneous respiratory rate	Yes
Texp	sec	Expiratory time	Yes
I:E	\	Inspiratory time:Expiratory time ratio	Yes
Ri	cmH2O/L/s,hPa/L/ s,mbar/L/s	Inspiratory resistance	Yes
Re	cmH2O/L/s,hPa/L/ s,mbar/L/s	Expiratory resistance	Yes
Cstat	ml/cmH2O,ml/ hPa,ml/mbar	Static compliance	Yes
RCexp	sec	Expiratory time constant	Yes
RCinsp	sec	Inspiratory time constant	No

Monitor output: parameters from Hamilton G5 ventilator (Block protocol)			
Labels	Units	Description	Trend, record, print
RSBI	1/(min.L)	Rapid shallow breathing index	Yes
O ₂ %	%	Oxygen concentration	Yes
WOB	J/L	Work of breathing	Yes
EtCO ₂	%,kPa,mmHg	End-tidal carbon dioxide	Yes
VCO ₂	ml/min	CO ₂ production	No
PR	/min	Pulse rate	Yes
SpO ₂	%	Arterial oxygen saturation from pulse oximetry	Yes
TVe/IBW	ml/kg	TVe/IBW	Yes
Setting Parameters			
f	/min	Breath rate	No
TV	ml	Tidal volume	No
TPause	%	Pause Time%	No
P-Trig	cmH2O, hPa, mbar	Inspiratory trigger level(pressure trigger)	No
PEEP/CPAP	cmH2O, hPa, mbar	PEEP/CPAP	No
Plow	cmH2O, hPa, mbar	Lower pressure level	No
ΔPsupp	cmH2O, hPa, mbar	Pressure support level	No
MV	L/min	Minute volume	No
Plimit	cmH2O, hPa, mbar	Pressure limit level	No
Pinsp	cmH2O, hPa, mbar	Pressure control level of inspiration	No
Phigh	cmH2O, hPa, mbar	Upper pressure level	No
F-Trig	L/min	Inspiratory trigger level (flow trigger)	No
I:E	\	Inspiratory time:Expiratory time ratio	No
Peak Flow	L/min	Peak flow	No
Exp%	%	Inspiration termination level	No

Monitor output: parameters from Hamilton G5 ventilator (Block protocol)			
Labels	Units	Description	Trend, record, print
Ramp	msec	Ramp	No
IBW	kg	Ideal body weight	No
%MinVol	%	Percentage of minute volume to be delivered	No
Tlow	sec	Time for the lower pressure level	No
Thigh	sec	Time for the upper pressure level	No
Ti max	sec	Maximum inspiration time	No
Tip	sec	Inspiratory pause time	No
Tube ID	mm	Tube ID	No
Base flow	L/min	Base Flow	No
O ₂ %	%	Oxygen concentration	No

4.17.2 Output Signals - Alarms

Monitor output: alarms from Hamilton G5 ventilator (Block protocol)		
Mindray Patient Monitor		Hamilton G5 Alarm
Priority	Label	Label
Physiological alarms		
High	Paw High	High pressure
High	Paw Low	Low pressure
High	FiO ₂ High	High oxygen
High	FiO ₂ Low	Low oxygen
High	Apnea	Apnea
High	Apnea Ventilation	Apnea ventilation
High	SpO ₂ Low	SpO ₂ too low
High	SpO ₂ High	SpO ₂ too high
High	MV Low	Low minute volume
High	MV High	High minute volume

Monitor output: alarms from Hamilton G5 ventilator (Block protocol)		
Mindray Patient Monitor		Hamilton G5 Alarm
Priority	Label	Label
High	Loss of PEEP	Loss of PEEP
Medium	RR High	High frequency
Medium	RR Low	Low frequency
Medium	EtCO ₂ High	High PetCO ₂
Medium	EtCO ₂ Low	Low PetCO ₂
Technical alarms		
High	Patient Disconnected	Disconnection Patient Disconnection on patient side
High	Air Supply Pressure Low	Air supply failed
High	O ₂ Supply Pressure Low	Oxygen supply failed
High	O ₂ cell disconnect	O ₂ cell missing
High	O ₂ cell cal. Needed	O ₂ cell calibration needed
High	Power Failure	Loss of mains power
High	Check Flow Sensors	Check Flow Sensor type
High	No Gas Supply Pressure	All gas supplies failed
High	Disconnection ventilator side	Disconnection Ventilator Disconnection on ventilator side
High	High Technical alarms	If the monitor shows the alarm [High Technical alarms], the external device may have the following alarms: Wrong Flow Sensor type O ₂ cell defective Disconnction Low internal pressure High pressure during sigh Pressure not released Exhalation obstructed TF5514:Check loudspeaker Internal battery empty Ventilator unit connection lost Check internal battery

Monitor output: alarms from Hamilton G5 ventilator (Block protocol)		
Mindray Patient Monitor		Hamilton G5 Alarm
Priority	Label	Label
Medium	O ₂ and air supply	Oxygen + air supplies failed
Medium	O ₂ and heliox supply	Oxygen + heliox supplies failed
Medium	Medium Technical alarms	<p>If the monitor shows the alarm [Medium Technical alarms], the external device may have the following alarms:</p> <ul style="list-style-type: none"> High leak Low tidal volume High tidal volume Turn the Flow Sensor APV init failed Internal battery low Panel connection lost Heliox supply failed SpO₂: sensor error(left slot) SpO₂: sensor error(right slot) SpO₂: no sensor (left slot) SpO₂: no sensor (right slot) SpO₂: patient disconnected (left slot) SpO₂: patient disconnected (right slot)

Monitor output: alarms from Hamilton G5 ventilator (Block protocol)		
Mindray Patient Monitor		Hamilton G5 Alarm
Priority	Label	Label
Medium	Medium Technical alarms	<p>SpO₂: light interference (left slot) SpO₂: light interference (right slot) SpO₂: poor signal (left slot) SpO₂: poor signal (right slot) Large change in FiO₂ Recruitment maneuver in process Brightness test alarm AERONEB disconnected Cuff disconnection Air + heliox supplies failed Oxygenation adjustment OFF (no SpO₂) Ventilation adjustment OFF (no PetCO₂) No hemodynamic status available High HLI MV oscillation FiO₂ oscillation PEEP oscillation Cuff high pressure FiO₂ set to 100% due to low saturation Check P ramp</p>
Low	Low Technical alarms	<p>If the monitor shows the alarm [Low Technical alarms], the external device may have the following alarms: Volume Low for nebulizer ASV: Check high pressure limit APV: Check high pressure limit Pressure low limit reached Check %MinVol Check Body Wt ASV: Cannot meet target Check PEEP/high pressure limit Check PEEP/Pcontrol Check PEEP/Psupport Check trigger Check %TI</p>

Monitor output: alarms from Hamilton G5 ventilator (Block protocol)		
Mindray Patient Monitor		Hamilton G5 Alarm
Priority	Label	Label
Low	Low Technical alarms	Check trigger Check %TI Check pause Check I:E Check Vt Check rate Check peak flow Check TI Check Flow Pattern Flow sensor calibration needed Expiratory valve calibration needed Apnea ventilation ended Maximum leak compensation Low ExpMinVol alarm off CO ₂ sensor calibration needed Check CO ₂ airway adapter CO ₂ sensor disconnected CO ₂ sensor over temperature CO ₂ sensor faulty External battery empty Sensor simulation active IRV Cuff leak IntelliCuff not found Check VThigh limit AERONEB module disconnected Oxygenation adjustment OFF (no SpO ₂) Ventilation adjustment OFF (no PetCO ₂) Check CO ₂ sampling line Check INTELLiVENT PEEP limit setting Set low limit of ExpMinVol alarm Recruitment in Progress Oxygenation Controller on Limit Ventilation Controller on Limit SBT conditions fulfilled SBT in progress

4.17.3 Output Signals - Waveforms (For BeneVision N series Monitors)

Label	Units
Paw	cmH2O, mbar, hpa
Flow	L/min
Vol	mL
CO2	mmHg, kPa, %

4.18 Hamilton G5/S1 (Polling Protocol)

4.18.1 Output Signals - Parameters

Monitor output: parameters from Hamilton G5/S1 ventilator (polling protocol)			
Labels	Units	Description	Trend, record, print
Monitoring Parameters			
O ₂ %	%	Oxygen concentration	Yes
MV	L/min	Minute volume	Yes
I: E	\	Inspiratory time:Expiratory time ratio	Yes
EtCO ₂	%,mmHg,kPa	End-tidal carbon dioxide	Yes
SpO ₂	%	Arterial oxygen saturation from pulse oximetry	Yes
PR	/min	Pulse rate	Yes
TVi	ml	Inspired tidal volume	Yes
TVe	ml	Expiratory tidal volume	Yes
ftotal	/min	Total respiratory rate	Yes
fspn	/min	Spontaneous respiratory rate	Yes
Ppeak	cmH2O, hPa, mbar	Peak pressure	Yes
Pmean	cmH2O, hPa, mbar	Mean pressure	Yes
Pplat	cmH2O, hPa, mbar	Plateau pressure	Yes
Texp	sec	Expiratory time	Yes

Monitor output: parameters from Hamilton G5/S1 ventilator (polling protocol)			
Labels	Units	Description	Trend, record, print
Ri	cmH2O/L/s,hPa/L/s,mbar/L/s	Inspiratory resistance	Yes
Re	cmH2O/L/s,hPa/L/s,mbar/L/s	Expiratory resistance	Yes
Cstat	ml/cmH2O,ml/hPa,ml/mbar	Static compliance	Yes
Insp Flow	L/min	Inspiration flow	No
TVe spn	ml	Spontaneous expiratory tidal volume	Yes
PEEPi	cmH2O, hPa, mbar	Intrinsic positive end-expiratory pressure	No
Pmin	cmH2O,hPa,mbar	Minimum airway pressure	No
P0.1	cmH2O, hPa, mbar	100 ms occlusion pressure	No
Exp Flow	L/min	Expiratory flow	No
RCexp	sec	Expiratory time constant	Yes
RCinsp	sec	Inspiratory time constant	No
WOB	J/L	Work of breathing	Yes
PTP	cmH2O.s,hPa.s,mbar.s	Pressure time product	No
PEEP	cmH2O, hPa, mbar	Positive end-expiratory pressure	Yes
Setting Parameters			
Phigh	cmH2O,hPa,mba	Upper pressure level	No
fCMV	/min	CMV frequency	No
fsimv	/min	Frequency of SIMV	No
TV	ml	Tidal volume	No
Tpause	%	Pause Time%	No
P-Trig	cmH2O,hPa,mba	Inspiratory trigger level(pressure trigger)	No
PEEP/CPAP	cmH2O, hPa, mbar	PEEP/CPAP	No
ΔPsupp	cmH2O, hPa, mbar	Pressure support level	No

Monitor output: parameters from Hamilton G5/S1 ventilator (polling protocol)			
Labels	Units	Description	Trend, record, print
O2%	%	Oxygen concentration	No
MV	L/min	Minute volume	No
I: E	\	Inspiratory time:Expiratory time ratio	No
Peak Flow	L/min	Peak flow	No
Exp%	%	Inspiration termination level	No
Ramp	msec	Ramp	No
IBW	kg	Ideal body weight	No
%MinVol	%	Percentage of minute volume to be delivered	No

4.18.2 Output Signals - Alarms

Monitor output: alarms from Hamilton G5/S1 ventilator (polling protocol)		
Mindray Patient Monitor		Hamilton G5/S1 Alarm
Priority	Label	Label
Physiological alarms		
High	Paw High	High pressure
High	Apnea	Apnea
High	Loss of PEEP	Loss of PEEP
High	MV Low	Low minute volume
High	MV High	High minute volume
Medium	RR High	High frequency
Technical alarms		
High	Disconnection ventilator side	Disconnection Ventilator or, Disconnection on ventilator side
High	Patient Disconnected	Disconnection Patient or, Disconnection on patient side

Monitor output: alarms from Hamilton G5/S1 ventilator (polling protocol)		
Mindray Patient Monitor		Hamilton G5/S1 Alarm
Priority	Label	Label
High	High Technical alarms	If the monitor shows the alarm [High Technical alarms], the external device may have the following alarms: OXYGEN CONCENTRATION.
Medium	Medium Technical alarms	If the monitor shows the alarm [Medium Technical alarms], the external device may have the following alarms: Gas Supply SPEZ ALARM
Low	Low Technical alarms	If the monitor shows the alarm [Low Technical alarms], the external device may have the following alarms: Operator General Alarm

4.19 Hamilton Galileo (Polling Protocol)

4.19.1 Output Signals - Parameters

Monitor output: parameters from Hamilton Galileo ventilator			
Labels	Units	Description	Trend, record, print
Monitoring Parameters			
O ₂ %	%	Oxygen concentration	Yes
MV	L/min	Minute volume	Yes
I: E	\	Inspiratory time:Expiratory time ratio	Yes
TVi	ml	Inspired tidal volume	Yes
TVe	ml	Expiratory tidal volume	Yes
ftotal	/min	Total respiratory rate	Yes
fspn	/min	Spontaneous respiratory rate	Yes
Ppeak	cmH ₂ O, hPa, mbar	Peak pressure	Yes

Monitor output: parameters from Hamilton Galileo ventilator			
Labels	Units	Description	Trend, record, print
Pmean	cmH2O, hPa, mbar	Mean pressure	Yes
Pplat	cmH2O, hPa, mbar	Plateau pressure	Yes
Texp	sec	Expiratory time	Yes
Ri	cmH2O/L/s, hPa/L/s, mbar/L/s	Inspiratory resistance	Yes
Re	cmH2O/L/s, hPa/L/s, mbar/L/s	Expiratory resistance	Yes
Cstat	ml/cmH2O, ml/hPa, ml/mbar	Static compliance	Yes
Insp Flow	L/min	Inspiration flow	No
PEEPi	cmH2O, hPa, mbar	Intrinsic positive end-expiratory pressure	Yes
Pmin	cmH2O, hPa, mbar	Minimum airway pressure	No
P0.1	cmH2O, hPa, mbar	100 ms occlusion pressure	No
Exp Flow	L/min	Expiratory flow	No
RCexp	sec	Expiratory time constant	Yes
RCinsp	sec	Inspiratory time constant	No
WOB	J/L	Work of breathing	Yes
PTP	cmH2O.s, hPa.s, mbar.s	Pressure time product	No
PEEP	cmH2O, hPa, mbar	Positive end-expiratory pressure	Yes
Setting Parameters			
fCMV	/min	CMV frequency	No
fsimv	/min	Frequency of SIMV	No
TV	ml	Tidal volume	No
Tpause	%	Pause Time%	No
P-Trig	cmH2O, hPa, mbar	Inspiratory trigger level (pressure trigger)	No
PEEP/CPAP	cmH2O, hPa, mbar	PEEP/CPAP	No
ΔPsupp	cmH2O, hPa, mbar	Pressure support level	No

Monitor output: parameters from Hamilton Galileo ventilator			
Labels	Units	Description	Trend, record, print
O ₂ %	%	Oxygen concentration	No
Phigh	cmH ₂ O, hPa, mbar	Upper pressure level	No
I: E	\	Inspiratory time:Expiratory time ratio	No
Peak Flow	L/min	Peak flow	No
Exp%	%	Inspiration termination level	No
Ramp	msec	Ramp	No
IBW	kg	Ideal body weight	No
%MinVol	%	Percentage of minute volume to be delivered	No

4.19.2 Output Signals - Alarms

Monitor output: alarms from Hamilton Galileo ventilator		
Mindray Patient Monitor		Hamilton Galileo Alarm
Priority	Label	Label
Physiological alarms		
High	Paw High	High Pressue
High	Apnea	Apnea
High	Loss of PEEP	Loss of PEEP
High	MV Low	Low Min Vol
High	MV High	High Min Vol
Medium	RR High	High Rate
Technical alarms		
High	Disconnection ventilator side	Disconnection Ventilator
High	Patient Disconnected	Disconnection Patient

Monitor output: alarms from Hamilton Galileo ventilator		
Mindray Patient Monitor		Hamilton Galileo Alarm
Priority	Label	Label
High	High Technical alarms	If the monitor shows the alarm [High Technical alarms], the external device may have the alarm: Oxygen Concentration
Medium	Medium Technical alarms	If the monitor shows the alarm [Medium Technical alarms], the external device may have the alarm: Gas Supply
Low	Low Technical alarms	If the monitor shows the alarm [Low Technical alarms], the external device may have the following alarms: Operator General Alarm

4.20 Hamilton S1 (Block Protocol)

4.20.1 Output Signals - Parameters

Monitor output: parameters from Hamilton S1 ventilator			
Labels	Units	Description	Trend, record, print
Monitoring Parameters			
O ₂ %	%	Oxygen concentration	Yes
PEEP	cmH ₂ O, hPa, mbar	Positive end-expiratory pressure	Yes
Ppeak	cmH ₂ O, hPa, mbar	Peak pressure	Yes
Pplat	cmH ₂ O, hPa, mbar	Plateau pressure	Yes
Pmean	cmH ₂ O, hPa, mbar	Mean pressure	Yes
TVe	ml	Expiratory tidal volume	Yes
TVi	ml	Inspired tidal volume	Yes
TVe/IBW	ml/kg	TVe/IBW	Yes
TVe spn	ml	Spontaneous expiratory tidal volume	Yes

Monitor output: parameters from Hamilton S1 ventilator			
Labels	Units	Description	Trend, record, print
MV	L/min	Minute volume	Yes
MVspn	L/min	Spontaneous breathed minute volume	Yes
ftotal	/min	Total respiratory rate	Yes
fspn	/min	Spontaneous respiratory rate	Yes
RSBI	1/(min.L)	Rapid shallow breathing index	Yes
I:E	\	Inspiratory time: Expiratory time ratio	Yes
Cstat	ml/cmH2O,ml/hPa,ml/mbar	Static compliance	Yes
WOB	J/L	Work of breathing	Yes
Insp Flow	L/min	Inspiration flow	No
Exp Flow	L/min	Expiratory flow	No
VCO ₂	ml/min	CO ₂ production	No
PR	/min	Pulse rate	Yes
Texp	sec	Expiratory time	Yes
Ri	cmH2O/L/s,hPa/L/s,mbar/L/s	Inspiratory resistance	Yes
Re	cmH2O/L/s,hPa/L/s,mbar/L/s	Expiratory resistance	Yes
RCexp	sec	Expiratory time constant	Yes
RCinsp	sec	Inspiratory time constant	No
PTP	cmH2O.s,hPa.s,mbar.s	Pressure time product	No
Pmin	cmH2O, hPa, mbar	Minimum airway pressure	No
P0.1	cmH2O, hPa, mbar	100 ms occlusion pressure	No
PEEPi	cmH2O, hPa, mbar	Intrinsic positive end-expiratory pressure	Yes
EtCO ₂	%,kPa,mmHg	End-tidal carbon dioxide	Yes
SpO ₂	%	Arterial oxygen saturation from pulse oximetry	Yes

Monitor output: parameters from Hamilton S1 ventilator			
Labels	Units	Description	Trend, record, print
Setting Parameters			
TV	ml	Tidal volume	No
f	/min	Breath rate	No
I:E	\	Inspiratory time: Expiratory time ratio	No
Base Flow	L/min	Base Flow	No
F-Trig	L/min	Inspiratory trigger level (flow trigger)	No
P-Trig	cmH2O, hPa, mbar	Inspiratory trigger level (pressure trigger)	No
Δ Psupp	cmH2O, hPa, mbar	Pressure support level	No
Pinsp	cmH2O, hPa, mbar	Pressure control level of inspiration	No
Tpause	%	Pause Time%	No
Phigh	cmH2O, hPa, mbar	Upper pressure level	No
Plow	cmH2O, hPa, mbar	Lower pressure level	No
Thigh	sec	Time for the upper pressure level	No
Tlow	sec	Time for the lower pressure level	No
Exp%	%	Inspiration termination level	No
Plimit	cmH2O, hPa, mbar	Pressure limit level	No
PEEP/CPAP	cmH2O, hPa, mbar	PEEP/CPAP	No
Peak Flow	L/min	Peak flow	No
IBW	kg	Ideal body weight	No
Ti max	sec	Maximum inspiration time	No
Tip	sec	Inspiratory pause time	No
Ramp	msec	Ramp	No
%MinVol	%	Percentage of minute volume to be delivered	No
Tube ID	mm	Tube ID	No

Monitor output: parameters from Hamilton S1 ventilator			
Labels	Units	Description	Trend, record, print
O ₂ %	%	Oxygen concentration	No
MV	L/min	Minute volume	No

4.20.2 Output Signals - Alarms

Monitor output: alarms from Hamilton S1 ventilator		
Mindray Patient Monitor		Hamilton S1 Alarm
Priority	Label	Label
Physiological alarms		
High	FiO ₂ High	high Oxygen
High	FiO ₂ Low	low Oxygen
High	PawLow	Low pressure
High	MV High	High minite volume
High	MV Low	Low minite volume
High	Apnea	Apnea
High	Paw High	high pressure
High	Loss of PEEP	Loss of PEEP
High	Apnea Ventilation	Apnea ventilation
High	SpO ₂ Low	SpO2 too low
High	SpO ₂ High	SpO2 too high
Medium	RR Low	Low frequency
Medium	RR High	High frequency
Medium	EtCO ₂ High	High PetCO2
Medium	EtCO ₂ Low	Low PetCO2
Technical alarms		
High	Patient Disconnected	Disconnection Patient
High	Air Supply Pressure Low	Air supply
High	O ₂ Supply Pressure Low	Oxygen supply

Monitor output: alarms from Hamilton S1 ventilator		
Mindray Patient Monitor		Hamilton S1 Alarm
Priority	Label	Label
High	O ₂ cell disconnect	O2 cell missing
High	O ₂ cell cal. Needed	O2 cell cal. needed
High	Disconnection ventilator side	Disconnection ventilator
High	Power Failure	Loss of mains power
High	Check Flow Sensors	Check Flow Sensor type
High	No Gas Supply Pressure	All gas supplies failed
High	High Technical Alarm	If the monitor shows the alarm [High Technical alarms], the external device may have the following alarms: Wrong Flow Sensor type O ₂ cell defective Disconnection Low internal pressure High pressure during sigh Pressure not released Exhalation obstructed TF 5514: Check loudspeaker Internal battery empty Ventilator unit connection lost Check internal battery
Medium	O ₂ and air supply	Oxygen and air supply
Medium	O ₂ and heliox supply	Oxygen and heliox supply

Monitor output: alarms from Hamilton S1 ventilator		
Mindray Patient Monitor		Hamilton S1 Alarm
Priority	Label	Label
Medium	Medium Technical Alarm	<p>If the monitor shows the alarm [Medium Technical alarms], the external device may have the following alarms:</p> <ul style="list-style-type: none"> High leak Low tidal volume High tidal volume Turn the Flow Sensor APV init Failed Check P-ramp Internal battery Low Panel connection lost Heliox supply failed SPO₂:sensor error (left slot) SPO₂:sensor error (right slot) SPO₂:no sensor (left slot) SPO₂:no sensor (right slot) SPO₂:patient disconnected (left slot) SPO₂:patient disconnected (right slot) SPO₂:light interference (left slot) SPO₂:light interference (right slot) SPO₂:poor signal (left slot) SPO₂:poor signal (right slot) Large change in FiO₂ Recruitment maneuver in progress Brightness test alarm AERONEB disconnected Cuff disconnection Air +heliox supplies failed Oxygenation adjustment OFF (no SpO₂) Ventilation adjustment OFF (no PetO₂) No hemodynamic status available High HLI MV oscillation FiO₂ oscillation PEEP oscillation Cuff high pressure FiO₂ set to 100% due to low saturation

Monitor output: alarms from Hamilton S1 ventilator		
Mindray Patient Monitor		Hamilton S1 Alarm
Priority	Label	Label
Low	Low Technical Alarm	<p>If the monitor shows the alarm [Low Technical alarms], the external device may have the following alarms:</p> <p>Volume too low for nebulizerASV: Check high pressure limit</p> <p>APV: Check high pressure limit pressure low limit reached</p> <p>Check %MinVol</p> <p>Check Body Wt</p> <p>ASV:Cannot meet target</p> <p>Check PEEP/high pressure limit</p> <p>Check PEEP/Pcontrol</p> <p>Check PEEP/Psupport</p> <p>Check trigger</p> <p>Check %TI</p> <p>Check pause</p> <p>Check I:E</p> <p>Check Vt</p> <p>Check rate</p> <p>Check peak flow</p> <p>Check TI</p> <p>Check FlowPattern</p> <p>Flow Sensor calibration needed</p> <p>Expiratory valve calibration needed</p> <p>Apnea ventilation ended</p> <p>Maximum leak compensation</p> <p>Low ExpMinVol alarm off</p> <p>CO₂ Sensor calibration needed</p> <p>Check CO₂ airway adapter</p> <p>CO₂ sensor disconnected</p> <p>CO₂ sensor over temperature</p> <p>CO₂ sensor faulty</p> <p>External battery empty</p> <p>Sensor simulation active</p> <p>IRV</p> <p>Cuff leak</p> <p>IntelliCuff not found</p>

Monitor output: alarms from Hamilton S1 ventilator		
Mindray Patient Monitor		Hamilton S1 Alarm
Priority	Label	Label
Low	Low Technical Alarm	<p>If the monitor shows the alarm [Low Technical alarms], the external device may have the following alarms:</p> <ul style="list-style-type: none"> Check VThigh limit AERONEB modle disconnected Oxygenation adjustment OFF(no SpO₂) Ventilation adjustment OFF(no PetO₂) Check CO2 sampling line Check INTELLIVENT PEEP limit setting Set low limit for ExpMinVol alram Recruitment in progress Oxygenation controller on limit Vetilation controller on limit SBT conditions fulfilled SBT in progress

4.20.3 Output Signals - Waveforms (For BeneVision N series Monitors)

Label	Units
Paw	cmH ₂ O, mbar, hpa
Flow	L/min
Vol	mL
CO ₂	mmHg, kPa, %

4.21 HuL Leoni Plus

4.21.1 Output Signals - Parameters

Monitor output: parameters from HuL Leoni Plus ventilator			
Labels	Units	Description	Trend, record, print
Monitoring Parameters			
PEEP	cmH2O, hPa, mbar	Positive end-expiratory pressure	Yes
FiO2	%.kPa,mmHg	Fractional concentration of O ₂ in inspired gas	Yes
FiO2%	%	Fractional concentration of O ₂ in inspired gas	Yes
Ppeak	cmH2O, hPa, mbar	Peak pressure	Yes
Pmean	cmH2O, hPa, mbar	Mean pressure	Yes
TVe	ml	Expiratory tidal volume	Yes
TVi	ml	Inspiratory tidal volume	Yes
MV	L/min	Minute volume	Yes
ftotal	/min	Total respiratory rate	Yes
fspn	/min	Spontaneous respiratory rate	Yes
Rstat	ml/cmH2O,ml/hPa,ml/mbar	Static lung resistance	Yes
Cdyn	ml/cmH2O,ml/hPa,ml/mbar	Dynamic compliance	Yes
SpO ₂	%	Arterial oxygen saturation from pulse oximetry	Yes
Setting Parameters			
O ₂ %	%	Oxygen concentration	No
TV	ml	Tidal volume	No
fapnea	/min	Breath rate for apnea ventilation	No
f	/min	Breath rate	No
I:E	\	Inspiratory time: Expiratory time ratio	No
F-Trig	L/min	Inspiratory trigger level (flow trigger)	No

Monitor output: parameters from HuL Leoni Plus ventilator			
Labels	Units	Description	Trend, record, print
Trigger	%	Trigger	No
Tinsp	sec	Time of inspiration	No
Pinsp	cmH2O, hPa, mbar	Pressure control level of inspiration	No
Pmax	cmH2O, hPa, mbar	Maximum airway pressure	No
Flow	L/min	Flow	No
Apnea Tinsp	sec	Apnea time	No
ΔPsupp	cmH2O, hPa, mbar	Pressure support level	No
PEEP	cmH2O, hPa, mbar	Positive end-expiratory pressure	No

4.21.2 Output Signals - Alarms

Monitor output: alarms from HuL Leoni Plus ventilator		
Mindray Patient Monitor		HuL Leoni Plus Alarm
Priority	Label	Label
Physiological alarms		
High	Apnea	Apnea
High	FiO ₂ High	O2 high
High	FiO ₂ Low	P: O2 too low
High	MV High	MV high
High	MV Low	MV low
High	PEEP Not Achieved	PEEP pressure not reached
High	PEEP High	PEEP too high
High	Pinsp Not Achieved	Set pressure not reachable
High	Ppeak High	Ppeak high
High	Ppeak Low	Ppeak low
High	SpO ₂ High	SpO2 too high
High	SpO ₂ Low	SpO2 too low

Monitor output: alarms from HuL Leoni Plus ventilator		
Mindray Patient Monitor		HuL Leoni Plus Alarm
Priority	Label	Label
High	TV Not Achieved	Volume not reached
Medium	RR High	Frequency too high
Medium	TVe High	VTe too high
Medium	TVe Low	Vte too low
Technical alarms		
High	Airway Obstructed?	
High	No O2 Pressure	
High	Patient Disconnected	
High	Check Flow Sensors	<p>If the monitor shows the alarm [Check Flow Sensors], the external device may have the following alarms:</p> <ul style="list-style-type: none"> Flow sensor broken Flowsensor fail Calibrate Flowsensor Flowsensor contaminated.

Monitor output: alarms from HuL Leoni Plus ventilator		
Mindray Patient Monitor		HuL Leoni Plus Alarm
Priority	Label	Label
High	High Technical Alarm	<p>If the monitor shows the alarm [High Technical alarms], the external device may have the following alarms:</p> <p>Air supply Air supply failed. Freshgas is O2 Battery empty. Mechanical ventilation stopped. Battery empty. Supply voltage too low Excess pressure Exsp-Tube Excess pressure Insp-Tube O2 and Air supply failed. Dosing fresh gas stopped. O2 supply Deviation pressure sensors Technical Failure Current consumption too high 3.3V supply on NetDCU too high 3.3V supply on NetDCU too low 5V supply on NetDCU too high 5V supply on NetDCU too low 12V supply on NetDCU too high 12V supply on NetDCU too low 24V supply on NetDCU too high 24V supply on NetDCU too low Versions not compatible Failsafe Controllerboard EEPROM checksum failed Patient safe: Reboot the device Sensor Fail Patient Pressure Driving gas blender failed. Checksum error Encoder without function</p>
Medium	FiO2 Sensor Disconnected	
Medium	Patient Connection Leak	

Monitor output: alarms from HuL Leoni Plus ventilator		
Mindray Patient Monitor		HuL Leoni Plus Alarm
Priority	Label	Label
Medium	Medium Technical Alarm	<p>If the monitor shows the alarm [Medium Technical alarms], the external device may have the following alarms:</p> <ul style="list-style-type: none"> Battery Fail Battery not connected Broken loudspeaker. Audible alarming not possible. Batteries deep discharged. Please change. O2 Calibration failure Broken microphone. No checking of audible alarming Battery almost empty Check O2 concentration Oximetry cable not connected SpO2: Sensor not connected SpO2: communication error SpO2: Sensor failure Oximetry cable failure O2 control aborted Low Perfusion SpO2: Sensor off patient SpO2: No cable connected SpO2: No adhesive sensor connected
Low	Battery in Use	
Low	Low Technical Alarm	<p>If the monitor shows the alarm [Low Technical alarms], the external device may have the following alarms:</p> <ul style="list-style-type: none"> Fan Fail Observe battery runtime Controllerboard EEPROM not write protected

4.22 Imtmedical Bellavista 1000 (For BeneVision N series Monitors)

4.22.1 Output Signals - Parameters

Monitor output: parameters from Imtmedical Bellavista 1000 ventilator			
Labels	Units	Description	Trend, record, print
Monitoring Parameters			
C20/C	/	ComplianceRatio	Yes
Cdyn	ml/cmH2O, ml/hPa, ml/mbar	Dynamic compliance	Yes
Cstat	ml/cmH2O, ml/hPa, ml/mbar	Static compliance	Yes
Δpes	cmH2O, hPa, mbar	Δpes	Yes
ΔPtp	cmH2O, hPa, mbar	ΔPtp	Yes
EtCO2	%, mmHg, kPa	End-tidal carbon dioxide	Yes
FiO2%	%	Fractional concentration of O2 in inspired gas	Yes
Flow	L/min	Flow	Yes
PEF	L/min	FlowExp Peak	Yes
PIF	L/min	FlowInsp Peak	Yes
I:E	/	Inspiratory time:Expiratory time ratio	Yes
Leak%	%	Leak%	Yes
MVCO2	mL/min	MVCO2	Yes
MVe	L/min	Expiratory minute volume	Yes
MVspn	L/min	Spontaneous breathed minute volume	Yes
MVi	L/min	Inspiratory minute volume	Yes
MVlspn	L/min	MVInsp Spont	Yes
PesI	cmH2O, hPa, mbar	PesI	Yes
PesE	cmH2O, hPa, mbar	PesE	Yes

Monitor output: parameters from lntmedical Bellavista 1000 ventilator			
Labels	Units	Description	Trend, record, print
P0.1	cmH2O, hPa, mbar	100 ms occlusion pressure	No
PEEP	cmH2O, hPa, mbar	Positive end-expiratory pressure	Yes
Pmean	cmH2O, hPa, mbar	Mean pressure	Yes
Ppeak	cmH2O, hPa, mbar	Peak pressure	Yes
Pplat	cmH2O, hPa, mbar	Plateau pressure	Yes
Ptpl	cmH2O, hPa, mbar	Ptpl	Yes
PtpE	cmH2O, hPa, mbar	PtpE	Yes
PR	/min	Pulse rate	Yes
ftotal	/min	Total breath rate	Yes
fspn	/min	Spontaneous respiratory rate	Yes
Re	cmH2O/L/s , mbar/L/s , hPa/L/s	Expiratory resistance	Yes
Ri	cmH2O/L/s , mbar/L/s , hPa/L/s	Inspiratory resistance	Yes
Rcexp	sec	Expiratory time constant	Yes
RSBI	1/(min.L)	Rapid shallow breathing index	Yes
SpO2	%	Arterial oxygen saturation from pulse oximetry	Yes
Texp	sec	Expiratory time	Yes
Tinsp	sec	Time of inspiration	Yes
Ti/Ttot	%	Duty cycle or ratio of inspiration time to total breathing cycle time (only during spontaneous breathing)	Yes
VDaw	ml	VDaw	Yes
VtAlv	ml	VtAlv	Yes

Monitor output: parameters from lntmedical Bellavista 1000 ventilator			
Labels	Units	Description	Trend, record, print
VTCO2	ml	CO2 tidal elimination	No
TVe	ml	Expiratory tidal volume	Yes
TVe/IBW	mL/kg	TVe/IBW	Yes
TVi	ml	Inspired tidal volume	Yes
WOB	J/L	Work of breathing	Yes
PEEPi	cmH2O, hPa, mbar	Intrinsic positive endexpiratory pressure	Yes
MVleak	L/min	Leakage minute volume	Yes
VDaw/ TVe	%	Vd/Vt Exp	Yes
Setting Parameters			
Exh Sens	%	Exh Sens	No
O2%	%	Fractional concentration of O2 in inspired gas	No
F-Trig	L/min	Inspiratory trigger level (flow trigger)	No
Flow	L/min	Flow	No
PEEP/ CPAP	cmH2O, mbar, hPa	PEEP/CPAP	No
Phigh	cmH2O, mbar, hPa	Upper pressure level	No
Pinsp	cmH2O, mbar, hPa	Pressure control level of inspiration	No
Plow	cmH2O, mbar, hPa	Lower pressure level	No
P-Trig	cmH2O, mbar, hPa	Inspiratory trigger level (pressure trigger)	No
Δ Psupp	cmH2O, mbar, hPa	Pressure support level	No
Tslope	msec	Rise time	No
f	/min	Breath rate	No
Thigh	sec	Time for the upper pressure level	No
Tinsp	sec	Time of inspiration	No

Monitor output: parameters from lntmedical Bellavista 1000 ventilator			
Labels	Units	Description	Trend, record, print
Ti max	sec	Maximum inspiration time	No
Tlow	sec	Time for the lower pressure level	No
TVi	ml	Inspired tidal volume	No
ATC	mm	Automatic Tube Compensation	No

4.23 MAQUET SERVO-i/SERVO-s

4.23.1 Output Signals - Parameters

Monitor output: parameters from MAQUET SERVO-i/SERVO-s ventilator			
Labels	Units	Description	Trend, record, print
Monitoring Parameters			
O ₂ %	%	Oxygen concentration	Yes
PEEP	cmH ₂ O, hPa, mbar	Positive end-expiratory pressure	Yes
Ppeak	cmH ₂ O, hPa, mbar	Peak pressure	Yes
Pplat	cmH ₂ O, hPa, mbar	Plateau pressure	Yes
Pmean	cmH ₂ O, hPa, mbar	Mean pressure	Yes
TVe	ml	Expiratory tidal volume	Yes
TVi	ml	Inspired tidal volume	Yes
MVspn	L/min	Spontaneous breathed minute volume	Yes
MVe	L/min	Expiratory minute volume	Yes
MVi	L/min	Inspiratory minute volume	Yes
ftotal	/min	Total respiratory rate	Yes
fspn	/min	Spontaneous respiratory rate	Yes
I:E	\	Inspiratory time:Expiratory time ratio	Yes
Leak Comp	%	Leak compensation	No

Monitor output: parameters from MAQUET SERVO-i/SERVO-s ventilator			
Labels	Units	Description	Trend, record, print
Cstat	ml/cmH2O,ml/hPa,ml/mbar	Static compliance	Yes
Cdyn	ml/cmH2O,ml/hPa,ml/mbar	Dynamic compliance	Yes
RSBI	1/(min.L)	Rapid shallow breathing index	Yes
WOB	J/L	Work of breathing	Yes
Exp Flow	L/min	Expiratory flow	No
Ri	cmH2O/L/s,hPa/L/s,mbar/L/s	Inspiratory resistance	Yes
Re	cmH2O/L/s,hPa/L/s,mbar/L/s	Expiratory resistance	Yes
PO ₂	kPa	oxygen supply pressure	No
Pair	kPa	air supply pressure	No
P0.1	cmH2O, hPa, mbar	100 ms occlusion pressure	No
PEEPtot	cmH2O, hPa, mbar	Total PEEP	Yes
EtCO ₂	%,kPa,mmHg	End-tidal carbon dioxide	Yes
EtCO ₂ %	%	End-tidal carbon dioxide	Yes
VCO ₂	ml/min	CO ₂ production	No
VTCO ₂	ml	CO ₂ tidal elimination	No
TI/TTOT	\	Duty cycle or ratio of inspiration time to total breathing cycle time (only during spontaneous breathing)	Yes
Setting Parameters			
TV	ml	Tidal volume	No
MV	L/min	Minute volume	No
fCMV	/min	CMV frequency	No
fsimv	/min	Frequency of SIMV	No
I:E	\	Inspiratory time:Expiratory time ratio	No

Monitor output: parameters from MAQUET SERVO-i/SERVO-s ventilator			
Labels	Units	Description	Trend, record, print
F-Trig	\	Inspiratory trigger level (flow trigger)	No
P-Trig	cmH2O, hPa, mbar	Inspiratory trigger level (pressure trigger)	No
Tinsp	sec	Time of inspiration	No
Tpause	%	Pause Time%	No
Rise Time%	%	rise time%	No
Phigh	cmH2O, hPa, mbar	Upper pressure level	No
Thigh	sec	Time for the upper pressure level	No
Tpeep	sec	Time at PEEP level in Bi-Vent	No
PC above PEEP	cmH2O, hPa, mbar	PC above PEEP	No
PS above PEEP	cmH2O, hPa, mbar	PS above PEEP	No
PEEP/CPAP	cmH2O, hPa, mbar	PEEP/CPAP	No
Plimit	cmH2O, hPa, mbar	Pressure limit level	No
fapnea	/min	Breath rate for apnea ventilation	No
Tpause	sec	Pause Time	No
Tslope	sec	Rise time	No
Apnea Tinsp	sec	Apnea time	No
TVapnea	ml	Apnea tidal volume	No
PEEP	cmH2O, hPa, mbar	Positive end-expiratory pressure	No
O ₂ %	%	Oxygen concentration	No

4.23.2 Output Signals - Alarms

Monitor output: alarms from MAQUET SERVO-i/SERVO-s ventilator		
Mindray Patient Monitor		MAQUET SERVO-i/SERVO-s Alarm
Priority	Label	Label
Physiological alarms		
High	Paw High	Airway pressure alarm Upper pressure limit exceeded
High	MV High	Exp.Minute volume too high
High	MV Low	Exp.Minute volume too low
High	Apnea	Apnea alarm
High	FiO ₂ High	O ₂ conc.too high
High	FiO ₂ Low	O ₂ conc.too low
High	PEEP High	PEEP High
High	PEEP Low	PEEP Low
Medium	EtCO ₂ High	EtCO ₂ conc.too high
Medium	EtCO ₂ Low	EtCO ₂ conc.too low
Medium	RR Low	Breath frequency Low
Medium	RR High	Breath frequency High
Technical alarms		
High	No Gas Supply Pressure	Gas supply alarm
High	O ₂ cell disconnect	O ₂ cell disconnect

Monitor output: alarms from MAQUET SERVO-i/SERVO-s ventilator		
Mindray Patient Monitor		MAQUET SERVO-i/SERVO-s Alarm
Priority	Label	Label
High	High Technical alarms	<p>If the monitor shows the alarm [High Technical alarms], the external device may have the following alarms:</p> <ul style="list-style-type: none"> Breathing system uP Module error Inspiratory control uP Module error Monitoring System uP Module error Battery alarm Power Failure Mains Failure O₂ potentiometer error CMV potentiometer error Range Switch error Mode Switch error Barometer error High continuous pressure Overrange Computer Interface Emulator hardware error NIV,Leakage out of range NIV,Time in waiting position exceeds 2 min regulation pressure limited NIV,No patient effort detected Unreliable Edi signal Check catheterposition/Edi invalid No consistent patient effort Check catheter position/RR and HR coupling
Medium	Medium Technical alarms	<p>If the monitor shows the alarm [Medium Technical alarms], the external device may have the following alarms:</p> <ul style="list-style-type: none"> Panel Interface uP Module error Exp.flow &CO₂ linearization uP Module error Alarm buff CI Battery Voltage Pneumatic-Edi out of synch Edi activity low No Edi signal detected Unsuccessful manual gas change alarm Check Heliox adapter

Monitor output: alarms from MAQUET SERVO-i/SERVO-s ventilator		
Mindray Patient Monitor		MAQUET SERVO-i/SERVO-s Alarm
Priority	Label	Label
Low	Check tubing	Check tubing
Low	Low Technical alarms	Leakage fraction too high

4.23.3 Output Signals - Waveforms (For BeneVision N series Monitors)

Label	Units
Paw	cmH2O, mbar, hpa
Flow	L/min
Vol	mL
CO2	%,kPa,mmHg

4.23.4 Output Signals - Respiratory Loops (For BeneVision N series Monitors)

Label	Units
PV Loop	cmH2O/ml, hPa/ml, mbar/ml
FV Loop	L/min/ml
PF Loop	cmH2O/L/min, hPa/L/min, mbar/L/min

4.24 MAQUET SERVO-U/SERVO-N/SERVO-Air

NOTE

- Only the Benevision N Series monitor supports integration with the MAQUET SERVO-N/SERVO Air ventilator.

4.24.1 Output Signals - Parameters

Monitor output: parameters from MAQUET SERVO-U/SERVO-N/SERVO-Air ventilator			
Labels	Units	Description	Trend, record, print
Monitoring Parameters			
O ₂ %	%	Oxygen concentration	Yes
PEEP	cmH ₂ O, hPa, mbar	Positive end-expiratory pressure	Yes
Ppeak	cmH ₂ O, hPa, mbar	Peak pressure	Yes
Pplat	cmH ₂ O, hPa, mbar	Plateau pressure	Yes
Pmean	cmH ₂ O, hPa, mbar	Mean pressure	Yes
TVe	ml	Expiratory tidal volume	Yes
TVi	ml	Inspired tidal volume	Yes
TVe/IBW	ml/kg	TVe/IBW	Yes
MVe	L/min	Expiratory minute volume	Yes
MVi	L/min	Inspiratory minute volume	Yes
MVspn	L/min	Spontaneous breathed minute volume	Yes
ftotal	/min	Total respiratory rate	Yes
fspn	/min	Spontaneous respiratory rate	Yes
I:E	\	Inspiratory time:Expiratory time ratio	Yes
TI/TTOT	\	Duty cycle or ratio of inspiration time to total breathing cycle time (only during spontaneous breathing)	Yes
Leak Comp	%	Leak compensation	No

Monitor output: parameters from MAQUET SERVO-U/SERVO-N/SERVO-Air ventilator			
Labels	Units	Description	Trend, record, print
Cstat	ml/cmH2O,ml/hPa,ml/mbar	Static compliance	Yes
Cdyn	ml/cmH2O,ml/hPa,ml/mbar	Dynamic compliance	Yes
RSBI	1/(min.L)	Rapid shallow breathing index	Yes
WOB	J/L	Work of breathing	Yes
Exp Flow	L/min	Expiratory flow	No
Ri	cmH2O/L/s,hPa/L/s,mbar/L/s	Inspiratory resistance	Yes
Re	cmH2O/L/s,hPa/L/s,mbar/L/s	Expiratory resistance	Yes
PO ₂	kPa	oxygen supply pressure	No
Pair	kPa	air supply pressure	No
P0.1	cmH2O, hPa, mbar	100 ms occlusion pressure	No
PEEPtot	cmH2O, hPa, mbar	Total PEEP	Yes
EtCO ₂	%,kPa,mmHg	End-tidal carbon dioxide	Yes
VCO ₂	ml/min	CO ₂ production	No
VT _{CO₂}	ml	CO ₂ tidal elimination	No
EtCO ₂ %	%	End-tidal carbon dioxide	Yes
Setting Parameters			
TV	ml	Tidal volume	No
TVapnea	ml	Apnea tidal volume	No
MV	L/min	Minute volume	No
fapnea	/min	Breath rate for apnea ventilation	No
f	/min	Breath rate	No
fsimv	/min	Frequency of SIMV	No
I:E	\	Inspiratory time: Expiratory time ratio	No
F-Trig	L/min	Inspiratory trigger level (flow trigger)	No

Monitor output: parameters from MAQUET SERVO-U/SERVO-N/SERVO-Air ventilator			
Labels	Units	Description	Trend, record, print
P-Trig	cmH2O, hPa, mbar	Inspiratory trigger level (pressure trigger)	No
Plimit	cmH2O, hPa, mbar	Pressure limit level	No
Tinsp	sec	Time of inspiration	No
Tpause	%	Pause Time%	No
Tslope	sec	Rise time	No
Rise Time%	%	rise time%	No
Phigh	cmH2O, hPa, mbar	Upper pressure level	No
Thigh	sec	Time for the upper pressure level	No
Tpeep	sec	Time at PEEP level in Bi-Vent	No
PC above PEEP	cmH2O, hPa, mbar	PC above PEEP	No
PS above PEEP	cmH2O, hPa, mbar	PS above PEEP	No
PEEP/CPAP	cmH2O, hPa, mbar	PEEP/CPAP	No
Flow	L/min	Flow	No
Apnea Tinsp	sec	Apnea time	No
O ₂ %	%	Oxygen concentration	No
PEEP	cmH2O, hPa, mbar	Positive end-expiratory pressure	No

4.24.2 Output Signals - Alarms

Monitor output: alarms from MAQUET SERVO-U/SERVO-N/SERVO-Air ventilator		
Mindray Patient Monitor		SERVO-U/SERVO-N/SERVO-Air Alarm
Priority	Label	Label
Physiological alarms		
High	Apnea	Apnea
High	FiO ₂ High	O2 concentration high
High	FiO ₂ Low	O2 concentration low
High	High Paw Sustained	Airway pressure continuously high
High	MV High	Expiratory minute volume high
High	MV Low	Expiratory minute volume low
High	Paw High	Airway pressure high
High	PEEP High	PEEP high
High	PEEP Low	PEEP low
Medium	EtCO ₂ High	EtCO2 high
Medium	EtCO ₂ Low	EtCO2 low
Medium	RR High	Respiratory rate High
Medium	RR Low	Respiratory rate low
Technical alarms		
High	Patient Disconnected	Patient_Disconnected
High	O2 cell disconnect	O2_cell_disconnect
High	No Gas Supply Pressure	No_Gas_Supply_Pressure
High	High Technical alarms	If the monitor shows the alarm [High Technical alarms], the external device may have the following alarms: Battery alarm Overrange alarm Time in waiting position > 2 min Patient disconnected > 1 min Leakage too high

Monitor output: alarms from MAQUET SERVO-U/SERVO-N/SERVO-Air ventilator		
Mindray Patient Monitor		SERVO-U/SERVO-N/SERVO-Air Alarm
Priority	Label	Label
Medium	Medium Technical alarms	If the monitor shows the alarm [Medium Technical alarms], the external device may have the following alarms: The nebulizer cannot be run on one battery No consistent patient effort No patient effort CPAP high CPAP low Expiratory cassette disconnected Edi signal invalid Edi signal interference from ECG
Low	Battery in Use	Battery_in_Use
Low	Low Technical alarms	If the monitor shows the alarm [Low Technical alarms], the external device may have the following alarms: Inconsistent Edi signal Volume delivery restricted Low Edi signal No Edi signal detected Expiratory cassette replaced

4.24.3 Output Signals - Waveforms (For BeneVision N series Monitors)

Label	Units
Paw	cmH2O, mbar, hpa
Flow	L/min
Vol	mL
CO2	%,kPa,mmHg

4.24.4 Output Signals - Respiratory Loops (For BeneVision N series Monitors)

Label	Units
PV Loop	cmH2O/ml, hPa/ml, mbar/ml
FV Loop	L/min/ml
PF Loop	cmH2O/L/min, hPa/L/min, mbar/L/min

4.25 Mindray NB300/NB350/NB380 (For BeneVision N series Monitors)

4.25.1 Output Signals - Parameters

Monitor output: parameters from Mindray NB300/NB350/NB380 ventilator			
Labels	Units	Description	Trend, record, print
Monitoring Parameters			
SpO2/ FiO2	/	SpO2/FiO2	Yes
OSI	cmH2O, hPa, mbar	OSI	Yes
RSS	cmH2O, hPa, mbar	RSS	Yes
FiO2%	%	Fractional concentration of O2 in inspired gas	Yes
Ppeak	cmH2O, hPa, mbar	Peak pressure	Yes
Pmean	cmH2O, hPa, mbar	Mean Pressure	Yes
PEEP	cmH2O, hPa, mbar	Positive end-expiratory pressure	Yes
Leak%	%	Leak%	Yes
fspn	/min	Spontaneous respiratory rate	Yes
I:E	/	Inspiratory time:Expiratory time ratio	Yes
Texp	sec	Expiratory time	Yes
Flow_High	L/min	High Pressure Flow	Yes
Flow_Low	L/min	Low Pressure Flow	Yes

Monitor output: parameters from Mindray NB300/NB350/NB380 ventilator			
Labels	Units	Description	Trend, record, print
SpO2	%	Arterial oxygen saturation from pulse oximetry	Yes
PR	/min	Pulse rate	Yes
PI	%	PI	Yes
EtCO2	mmHg, %, kPa	End-tidal carbon dioxide	Yes
Setting Parameters			
O2%	%	Oxygen concentration	No
CPAP	cmH2O, hPa, mbar	CPAP	No
f	/min	Breath rate	No
Tinsp	sec	Time of inspiration	No
I:E	/	Inspiratory time:Expiratory time ratio	No
PEEP	cmH2O, hPa, mbar	Positive end-expiratory pressure	No
Pinsp	cmH2O, hPa, mbar	Pressure control level of inspiration	No
Pwakeup	cmH2O, hPa, mbar	Pressure of wakeup	No
Trigger	/	Trigger	No
fapnea	/min	Breath rate for apnea ventilation	No
Wakeup cycles	/	Wakeup cycles	No
Flow	L/min	Flow	No

4.25.2 Output Signals - Alarms

Monitor output: alarms from Mindray NB300/NB350/NB380 ventilator		
Mindray Patient Monitor		NB300/NB350/NB380 Alarm
Priority	Label	Label
Physiological alarms		

Monitor output: alarms from Mindray NB300/NB350/NB380 ventilator		
Mindray Patient Monitor		NB300/NB350/NB380 Alarm
Priority	Label	Label
High	Vent Wakeup	Wakeup Vent
High	No Pulse	No Pulse
High	Paw High	Paw Too High
High	Paw High	Paw Too Low
High	FiO2 High	FiO2 Too High
High	FiO2 Low	FiO2 Too Low
High	Apnea	Apnea
High	Apnea Ventilation	Apnea Ventilation
High	SpO2 High	SpO2 Too High
High	SpO2 Low	SpO2 Too Low
High	SpO2 Desat	SpO2 Desat
High	Pinsp Not Achieved	Pinsp Not Achieved
High	PR High	PR Too High
High	PR Low	PR Too Low
Medium	EtCO2 Low	EtCO2 Too Low
Medium	EtCO2 High	EtCO2 Too High
Low	Apnea Ventilation Ended	Apnea Ventilation Ended
Technical alarms		
High	Airway Obstructed?	Airway Obstructed?
High	Tube Disconnected?	Tube Disconnected?
High	O2 Supply Pressure Low	O2 Supply Pressure Low
High	Air Supply Pressure Low	Air Supply Pressure Low
High	No Gas Supply Pressure	No Gas Supply Pressure

Monitor output: alarms from Mindray NB300/NB350/NB380 ventilator		
Mindray Patient Monitor		NB300/NB350/NB380 Alarm
Priority	Label	Label
High	High Technical Alarm	If the monitor shows the alarm [High Technical alarms], the external device may have the following alarms: Please perform pressure calibration. Please perform flow calibration. Battery Temp High. Syst maybe Down System DOWN. Connect Ext. Power. Battery Undetected
Medium	Medium Technical Alarm	If the monitor shows the alarm [Medium Technical Alarm], the external device may have the following alarms: Replace O2 sensor Battery Temp. High. Connect Ext. Pwr. Low Battery. Connect Ext. Power. CO2 Module Failure 01\nCO2 Zero Failed CO2 Module Failure 02\nCO2 Init Error CO2 Module Failure 03\nCO2 Selftest Error CO2 Module Failure 04\nCO2 Hardware Error Please Replace SpO2 Sensor SpO2 Module Error\nSpO2 Init Err
Low	Airway Leak?	Airway Leak?
Low	O2 Sensor Unconnected	O2 Sensor Disconnected
Low	Battery in Use	Battery in Use
Low	CO2 No Watertrap	CO2 No Watertrap

Monitor output: alarms from Mindray NB300/NB350/NB380 ventilator		
Mindray Patient Monitor		NB300/NB350/NB380 Alarm
Priority	Label	Label
Low	Low Technical Alarm	<p>If the monitor shows the alarm [Low Technical Alarm], the external device may have the following alarms:</p> <p>Please Reset Date and Time</p> <p>IP Address Conflict. Please Reset IP.</p> <p>Please calibrate O2 sensor</p> <p>CO2 Sampleline Occluded</p> <p>CO2 Sensor High Temp</p> <p>EtCO2 Overrange</p> <p>SpO2 Sensor Off</p> <p>SpO2 No Sensor</p> <p>SpO2 Too Much Light</p> <p>SpO2 No Pulse</p> <p>SpO2 Overrange</p> <p>PR Overrange</p>

4.25.3 Output Signals - Waveforms (For BeneVision N series Monitors)

Label	Units
Paw	cmH2O, mbar, hpa
Pleth	/
CO2	mmHg, kPa, %

4.26 Mindray SV60/SV60S/SV70/SV70S (For BeneVision N Series Monitors)

4.26.1 Output Signals - Parameters

Monitor output: parameters from Mindray SV60/SV60S/SV70/SV70S ventilator			
Labels	Units	Description	Trend, record, print
Monitoring Parameters			
PEEP	cmH2O, hPa, mbar	Positive end-expiratory pressure	Yes
Ppeak	cmH2O, hPa, mbar	Peak pressure	Yes
Pmean	cmH2O, hPa, mbar	Mean pressure	Yes
TVe	ml	Expiratory tidal volume	Yes
TVe/IBW	ml/kg, ml/lb	TVe/IBW	Yes
MVe	L/min	Expiratory minute volume	Yes
ftotal	/min	Total respiratory rate	Yes
fmand	/min	Mandatory breathing frequency	Yes
fspn	/min	Spontaneous respiratory rate	Yes
FiO ₂	%,Kpa,mmHg	Fractional concentration of O ₂ ininspired gas	Yes
FiO ₂ %	%	Fractional concentration of O ₂ ininspired gas	Yes
PEEPi	cmH2O, hPa, mbar	Intrinsic positive end-expiratory pressure	Yes
EtCO ₂	%,Kpa,mmHg	End-tidal carbon dioxide	Yes
EtCO ₂ %	%	End-tidal carbon dioxide	Yes
PR	/min	Pulse rate	Yes
PI	%	PI	Yes
SpO ₂	%	Arterial oxygen saturation from pulse oximetry	Yes
Insp Flow	L/min	Inspiration flow	Yes
Ptpl	cmH2O/hPa/mbar	Ptpl	Yes
PtpE	cmH2O/hPa/mbar	PtpE	Yes
△ Ptp	cmH2O/hPa/mbar	△ Ptp	Yes
PesI	cmH2O/hPa/mbar	PesI	Yes
PesE	cmH2O/hPa/mbar	PesE	Yes
△ Pes	cmH2O/hPa/mbar	△ Pes	Yes

Monitor output: parameters from Mindray SV60/SV60S/SV70/SV70S ventilator			
Labels	Units	Description	Trend, record, print
PTPes	cmH2O*s/hPa*s/ mbar*s	PTPes	Yes
P T P e s / min	cmH2O*/min hPa*/min mbar*/min	PTPes/min	Yes
PEEPtot	cmH2O, hPa, mbar	PEEPi+PEEP	Yes
Pt.leak	L/min	Pt.leak	Yes
Tot.leak	L/min	Tot.leak	Yes
Pt.Trig	%	Pt.Trig	Yes
Ti/Ttot	%	Ti/Ttot	Yes
ROX	/	ROX	Yes
Setting Parameters			
O2%	%	Oxygen concentration	No
TV	ml	Tidal volume	No
f	/min	Breath rate	No
Psupp	cmH2O, hPa, mbar	Pressure support level	No
Tinsp	sec	Time of inspiration	No
Flow	L/min	Flow	No
IBW	kg,lb	Ideal body weight	No
IPAP	cmH2O, hPa, mbar	IPAP	No
CPAP	cmH2O, hPa, mbar	CPAP	No
Tslpoe(NIV)	/	Tslpoe(NIV)	No
Trigger	/	Trigger	No
E-Cycle	/	E-Cycle	No
P-Flex	/	P-Flex	No
Pmin	cmH2O, hPa, mbar	Pmin	No
Pmax	cmH2O, hPa, mbar	Pmax	No
TVmax	ml	TVmax	No
PPV%	%	PPV%	No

Monitor output: parameters from Mindray SV60/SV60S/SV70/SV70S ventilator			
Labels	Units	Description	Trend, record, print
Max E	cmH2O/L, hPa /L, mbar /L	Max E	No
Max R	cmH2O/L/s, hPa / L/s, mbar /L/s	Max R	No
EPAPmin	cmH2O, hPa, mbar	EPAPmin	No
EPAPmax	cmH2O, hPa, mbar	EPAPmax	No
Pbackup	cmH2O, hPa, mbar	Pbackup	No
fbackup	/min	fbackup	No
Interval[s]	sec	Interval[s]	No

4.26.2 Output Signals - Alarms

Monitor output: alarms from Mindray SV60/SV60S/SV70/SV70S ventilator		
Mindray Patient Monitor		SV60/SV60S/SV70/SV70S Alarm
Priority	Label	Label
Physiological alarms		
High	Paw Too High	Paw Too High
High	Paw Too Low	Paw Too Low
High	MV Too High	MV Too High
High	MV Too Low	MV Too Low
High	FiO2 Too High	FiO2 Too High
High	FiO2 Too Low	FiO2 Too Low
High	Backup Vent	Backup Vent
High	Apnea	Apnea
High	SpO2 Desat	SpO2 Desat
High	No Pulse	No Pulse
Medium	ftotal Too Low	ftotal Too Low
Medium	ftotal Too High	ftotal Too High

Monitor output: alarms from Mindray SV60/SV60S/SV70/SV70S ventilator		
Mindray Patient Monitor		SV60/SV60S/SV70/SV70S Alarm
Priority	Label	Label
Medium	SpO2 Too High	SpO2 Too High
Medium	SpO2 Too Low	SpO2 Too Low
Medium	PR Too High	PR Too High
Medium	PR Too Low	PR Too Low
Medium	Apnea CO2	Apnea CO2
Medium	TVe Too High	TVe Too High
Medium	TVe Too Low	TVe Too Low
Medium	EtCO2 Too High	EtCO2 Too High
Medium	EtCO2 Too Low	EtCO2 Too Low
Low	Backup Ventilation Ended	Backup Ventilation Ended
Technical alarms		
High	Airway Obstructed?	Airway Obstructed?
High	Tube Disconnected?	Tube Disconnected?
High	Sustained Airway Pressure	Sustained Airway Pressure
High	PEEP Too High	PEEP Too High
High	Please perform pressure calibration.	Please perform pressure calibration.
High	Please perform prop calibration.	Please perform prop calibration.
High	Battery Undetected	Battery Undetected
High	Insp. Gas Temp Too High	Insp. Gas Temp Too High
High	System DOWN. Connect Ext. Power.	System DOWN. Connect Ext. Power.
High	Low Leak-CO2 Rebreathing Risk	Low Leak-CO2 Rebreathing Risk
High	PPV Pressure Too High	PPV Pressure Too High
High	PPV TV Too High	PPV TV Too High
High	Proximal Pressure Line Disconnected	Proximal Pressure Line Disconnected

Monitor output: alarms from Mindray SV60/SV60S/SV70/SV70S ventilator		
Mindray Patient Monitor		SV60/SV60S/SV70/SV70S Alarm
Priority	Label	Label
High	High O2 Supply Pressure	High O2 Supply Pressure
High	Device Failure	Device Failure 01/02/03/04/05/06/09/12/13/ 19/20/21/22/23
High	Battery Failure	Battery 1 Failure 02/03/04/05 Battery 2 Failure 02 /03/04/05
High	Blower Failure	Blower Failure 03/04
High	High Technical alarms	If the monitor shows the alarm [High Technical alarms], the external device may have the following alarms: Blower Temperature High Battery Temp High. Syst maybe Down Please calibrate auxiliary pressure sensor IOC Paused High IOC O2% limit
Medium	PEEP Too Low	PEEP Too Low
Medium	Replace O2 sensor	Replace O2 sensor
Medium	Battery Temp. High. Connect Ext. Pwr.	Battery Temp. High. Connect Ext. Pwr.
Medium	Please Replace SpO2 Sensor	Please Replace SpO2 Sensor
Medium	CO2 Module Failure 01	CO2 Module Failure 01
Medium	CO2 Module Failure 02	CO2 Module Failure 02
Medium	CO2 Module Failure 03	CO2 Module Failure 03
Medium	CO2 Module Failure 04	CO2 Module Failure 04
Medium	Low Battery. Connect Ext. Power.	Low Battery. Connect Ext. Power.
Medium	Top Fan Failure	Top Fan Failure
Medium	Technical Error	Technical Error 02/05/07/09
Medium	Blower Technical Error	Blower Technical Error 01

Monitor output: alarms from Mindray SV60/SV60S/SV70/SV70S ventilator		
Mindray Patient Monitor		SV60/SV60S/SV70/SV70S Alarm
Priority	Label	Label
Medium	Medium Technical alarms	If the monitor shows the alarm [Medium Technical alarms], the external device may have the following alarms: Blower Fan Failure Low IOC O2% limit
Low	O2 Sensor Unconnected	O2 Sensor Unconnected
Low	Pinsp Not Achieved	Pinsp Not Achieved
Low	CO2 No Watertrap	CO2 No Watertrap
Low	CO2 Sensor High Temp	CO2 Sensor High Temp
Low	CO2 Sampleline Occluded	CO2 Sampleline Occluded
Low	EtCO2 Overrange	EtCO2 Overrange
Low	Battery in Use	Battery in Use
Low	Please calibrate O2 sensor	Please calibrate O2 sensor
Low	SpO2 No Pulse	SpO2 No Pulse
Low	SpO2 Sensor Off	SpO2 Sensor Off
Low	SpO2 No Sensor	SpO2 No Sensor
Low	SpO2 Too Much Light	SpO2 Too Much Light
Low	SpO2 Overrange	SpO2 Overrange
Low	PR Overrange	PR Overrange
Low	Replace HEPA Filter	Replace HEPA Filter
Low	VAPS: Target TV Not Achieved. Insufficient Pmax	VAPS: Target TV Not Achieved. Insufficient Pmax
Low	VAPS: Target TV Exceeded. Pmin Too High	VAPS: Target TV Exceeded. Pmin Too High
Low	Technical Error	Technical Error 04
Low	Low Technical alarms	If the monitor shows the alarm [Low Technical alarms], the external device may have the following alarms: Storage Error

4.26.3 Output Signals - Waveforms

Label	Units
Paw	cmH2O, mbar, hpa
Flow	L/min
Vol	mL
CO2	%,kPa,mmHg
SpO2	/
Pes	cmH2O, mbar, hpa
Ptp	cmH2O, mbar, hpa

4.27 Mindray SV300/350/600/650/800/850

NOTE

- Only SV300 with software version 04.00.00 or later can be connected to the BeneLink module.

4.27.1 Output Signals - Parameters

Monitor output: parameters from Mindray SV300/350/600/650/800/850 ventilator			
Labels	Units	Description	Trend, record, print
Monitoring Parameters			
PEEP	cmH2O, hPa, mbar	Positive end-expiratory pressure	Yes
Ppeak	cmH2O, hPa, mbar	Peak pressure	Yes
Pplat	cmH2O, hPa, mbar	Plateau pressure	Yes
O ₂ %	%	Oxygen concentration	Yes
Pmean	cmH2O, hPa, mbar	Mean pressure	Yes
TVi	ml	Inspired tidal volume	Yes
TVe	ml	Expiratory tidal volume	Yes
TVe/IBW	ml/kg,ml/lb	TVe/IBW	Yes
TVe spn	ml	Spontaneous expiratory tidal volume	Yes

Monitor output: parameters from Mindray SV300/350/600/650/800/850 ventilator			
Labels	Units	Description	Trend, record, print
MVe	L/min	Expiratory minute volume	Yes
MVspn	L/min	Spontaneous breathed minute volume	Yes
ftotal	/min	Total respiratory rate	Yes
fmand	/min	Mandatory breathing frequency	Yes
fspn	/min	Spontaneous respiratory rate	Yes
I:E	\	Inspiratory time: Expiratory time ratio	Yes
MV Leak	L/min	Leakage minute volume	Yes
FiO ₂	%,Kpa,mmHg	Fractional concentration of O ₂ in inspired gas	Yes
Cstat	ml/cmH ₂ O,ml/hPa,ml/mbar	Static compliance	Yes
Cdyn	ml/cmH ₂ O,ml/hPa,ml/mbar	Dynamic compliance	Yes
RSBI	1/(min.L)	Rapid shallow breathing index	Yes
WOBimp	J/min	Imposed work of breathing	Yes
Ri	cmH ₂ O/L/s,hPa/L/s,mbar/L/s	Inspiratory resistance	Yes
Re	cmH ₂ O/L/s,hPa/L/s,mbar/L/s	Expiratory resistance	Yes
RCexp	sec	Expiratory time constant	Yes
NIF	cmH ₂ O, hPa, mbar	Negative inspiratory force	No
P0.1	cmH ₂ O, hPa, mbar	100 ms occlusion pressure	No
PEEPi	cmH ₂ O, hPa, mbar	Intrinsic positive end-expiratory pressure	Yes
EtCO ₂	%,Kpa,mmHg	End-tidal carbon dioxide	Yes
VCO ₂	ml/min	CO ₂ production	No
PR	/min	Pulse rate	Yes
SpO ₂	%	Arterial oxygen saturation from pulse oximetry	Yes
Insp Flow	L/min	Inspiration flow	Yes

Monitor output: parameters from Mindray SV300/350/600/650/800/850 ventilator			
Labels	Units	Description	Trend, record, print
FiCO2	%,Kpa,mmHg	Fraction of inspired carbon dioxide	Yes
C20/C	/	Compliance Ratio	Yes
Tinsp	sec	Time of inspiration	Yes
MVi	L/min	Inspiratory minute volume	Yes
Ptpl	cmH2O/hPa/mbar	Ptpl	Yes
PtpE	cmH2O/hPa/mbar	PtpE	Yes
△ Ptp	cmH2O/hPa/mbar	△ Ptp	Yes
Pesl	cmH2O/hPa/mbar	Pesl	Yes
PesE	cmH2O/hPa/mbar	PesE	Yes
△ Pes	cmH2O/hPa/mbar	△ Pes	Yes
PTPes	cmH2O*s/hPa*s/ mbar*s	PTPes	Yes
P T P e s / min	cmH2O*s/min hPa*s/min mbar*s/min	PTPes/min	Yes
Paux2l	cmH2O/hPa/mbar	Paux2l	Yes
Paux2E	cmH2O/hPa/mbar	Paux2E	Yes
Leak%	%	Leak%	Yes
FiO2%	%	Fractional concentration of O2 in inspired gas	Yes
fspn/ ftotal	%	fspn/ftotal	Yes
WOB	J/min	Work of breathing	Yes
WOBpat	J/min	WOBpat	Yes
WOBvent	J/min	WOBvent	Yes
PIF	L/min	FlowInsp Peak	Yes
PEF	L/min	FlowExp Peak	Yes
EEF	L/min	EEF	Yes
Stress Index	/	Stress Index	Yes

Monitor output: parameters from Mindray SV300/350/600/650/800/850 ventilator			
Labels	Units	Description	Trend, record, print
Vtrap	ml	Trapped volume	Yes
MPrs	J/min	MPrs	Yes
Pdrive	cmH2O/hPa/mbar	Pdrive	Yes
Clung	ml/cmH2O,ml/ hPa,ml/mbar	Clung	Yes
Ccw	ml/cmH2O,ml/ hPa,ml/mbar	Ccw	Yes
PI	%	PI	Yes
EtCO2%	%	End-tidal carbon dioxide	Yes
FiCO2%	%	Fraction of inspired carbon dioxide	Yes
SlopeCO2	mmHg/L,kPa/L,% / L	SlopeCO2	No
Vtalv	ml	Vtalv	Yes
MValv	L/min	MValv	No
Vdaw	ml	Vdaw	Yes
VDaw/ TVe	%	VDaw/TVe	Yes
VeCO2	ml	VeCO2	No
ViCO2	ml	ViCO2	No
Setting Parameters			
O ₂ %	%	Oxygen concentration	No
TV	ml	Tidal volume	No
TVApnea	ml	Apnea tidal volume	No
fapnea	/min	Breath rate for apnea ventilation	No
fsimv	/min	Frequency of SIMV	No
f	/min	Breath rate	No
Cycles Sigh	/min	Sigh rate	No
Δint. PEEP	cmH2O, hPa, mbar	Intermittent PEEP	No

Monitor output: parameters from Mindray SV300/350/600/650/800/850 ventilator			
Labels	Units	Description	Trend, record, print
F-Trig	L/min	Inspiratory trigger level (flow trigger)	No
P-Trig	cmH2O, hPa, mbar	Inspiratory trigger level (pressure trigger)	No
Δ Psupp	cmH2O, hPa, mbar	Pressure support level	No
Tinsp	sec	Time of inspiration	No
Pinsp	cmH2O, hPa, mbar	Pressure control level of inspiration	No
Papnea	cmH2O, hPa, mbar	Apnea pressure	No
Tpause	%	Apnea Time	No
Tslope	sec	Rise time	No
Phigh	cmH2O, hPa, mbar	Upper pressure level	No
Plow	cmH2O, hPa, mbar	Lower pressure level	No
Thigh	sec	Time for the upper pressure level	No
Tlow	sec	Time for the lower pressure level	No
Exp%	%	Inspiration termination level	No
Flow	L/min	Flow	No
IBW	kg,lb	Ideal body weight	No
Tube ID	mm	Tube ID	No
ATC	%	Automatic Tube Compensation	No
PEEP	cmH2O, hPa, mbar	Positive end-expiratory pressure	No
Plimit	cmH2O, hPa, mbar	Pressure limit level	No
Δ Pinsp	cmH2O, hPa, mbar	Delta Pinsp	No
I:E	\	Inspiratory time: Expiratory time ratio	No
MV%	%	MV%	No
Ti max	sec	Maximum inspiration time	No
Δ papnea	cmH2O, hPa, mbar	Δ papnea	No

Monitor output: parameters from Mindray SV300/350/600/650/800/850 ventilator			
Labels	Units	Description	Trend, record, print
Apnea Tinsp	sec	Apnea Tinsp	No
Δ PmanInsp	cmH ₂ O, hPa, mbar	Δ PmanInsp	No
TmanInsp	sec	TmanInsp	No

4.27.2 Output Signals - Alarms

Monitor output: alarms from Mindray SV300/350/600/650/800/850 ventilator		
Mindray Patient Monitor		SV300/350/600/650/800/850 Alarm
Priority	Label	Label
Physiological alarms		
High	Paw Too High	Paw Too High
High	Paw Too Low	Paw Too Low
High	MV Too High	MV Too High
High	MV Too Low	MV Too Low
High	FiO ₂ Too High	FiO ₂ Too High
High	FiO ₂ Too Low	FiO ₂ Too Low
High	Apnea Ventilation	Apnea Ventilation
High	Apnea	Apnea
High	SpO ₂ Desat	SpO ₂ Desat
High	No Pulse	No Pulse
Medium	Apnea CO ₂	Apnea CO ₂
Medium	TVe Too High	TVe Too High
Medium	TVe Too Low	TVe Too Low
Medium	EtCO ₂ Too High	EtCO ₂ Too High
Medium	EtCO ₂ Too Low	EtCO ₂ Too Low
Medium	ftotal Too High	ftotal Too High
Medium	ftotal Too Low	ftotal Too Low

Monitor output: alarms from Mindray SV300/350/600/650/800/850 ventilator		
Mindray Patient Monitor		SV300/350/600/650/800/850 Alarm
Priority	Label	Label
Medium	SpO2 Too High	SpO2 Too High
Medium	SpO2 Too Low	SpO2 Too Low
Medium	PR Too High	PR Too High
Medium	PR Too Low	PR Too Low
Low	Apnea Ventilation Ended	Apnea Ventilation Ended
Technical alarms		
High	Air Supply Failure	Air Supply Failure
High	O2 Supply Failure	O2 Supply Failure
High	No Gas Supply Pressure	No Gas Supply Pressure
High	Airway Obstructed?	Airway Obstructed?
High	Tube Disconnected?	Tube Disconnected?
High	Sustained Airway Pressure	Sustained Airway Pressure
High	Neo Flow Sensor Failure	Neo Flow Sensor Failure
High	PEEP Too High	PEEP Too High
High	Please Check Exp. Flow Sensor	Please Check Exp. Flow Sensor
High	Insp. Gas Temp Too High	Insp. Gas Temp Too High
High	Please perform pressure calibration	Please perform pressure calibration
High	Please perform flow calibration	Please perform flow calibration
High	Flow Sensor Type Error	Flow Sensor Type Error
High	System DOWN. Connect Ext. Power.	System DOWN. Connect Ext. Power.
High	Battery Undetected	Battery Undetected
High	Neo. Flow Sensor Reversed	Neo. Flow Sensor Reversed
High	Neo. Flow Sensor Overrange	Neo. Flow Sensor Overrange
High	No Neo. Flow Sensor	No Neo. Flow Sensor

Monitor output: alarms from Mindray SV300/350/600/650/800/850 ventilator		
Mindray Patient Monitor		SV300/350/600/650/800/850 Alarm
Priority	Label	Label
High	Wrong Neo. Flow Sensor Type	Wrong Neo. Flow Sensor Type
High	Device Failure	Device Failure 01/02/03/04/05/06/07/08/09/10/12/13/16/17/18/19/20/21/22/23
High	Battery Failure	Battery 1 Failure 01/02/03/04/05 Battery 2 Failure 01/02/03/04/05
High	Blower Failure	Blower Failure 01/02/03/04/05
High	High Technical alarms	If the monitor shows the alarm [High Technical alarms], the external device may have the following alarms: Blower Temperature High Battery Temp High. Syst maybe Down IOC Paused High IOC PEEP limit High IOC O2% limit Clean Neo. Flow Sensor Please Replace Battery 1 Please Replace Battery 2 Please calibrate auxiliary pressure sensor
Medium	Insp. Limb Airway Obstructed?	Insp. Limb Airway Obstructed?
Medium	PEEP Too Low	PEEP Too Low
Medium	Fan Failure	Fan Failure
Medium	Replace O2 sensor	Replace O2 sensor
Medium	CO2 Module Failure 01	CO2 Module Failure 01
Medium	Please Replace CO2 Sensor	Please Replace CO2 Sensor
Medium	Battery Temp. High. Connect Ext. Pwr.	Battery Temp. High. Connect Ext. Pwr.
Medium	Low Battery. Connect Ext. Power.	Low Battery. Connect Ext. Power.
Medium	Please Replace SpO2 Sensor	Please Replace SpO2 Sensor
Medium	SpO2 Module Error	SpO2 Module Error

Monitor output: alarms from Mindray SV300/350/600/650/800/850 ventilator		
Mindray Patient Monitor		SV300/350/600/650/800/850 Alarm
Priority	Label	Label
Medium	CO2 Module Failure 06	CO2 Module Failure 06
Medium	CO2 Module Failure 04	CO2 Module Failure 04
Medium	CO2 Module Failure 02	CO2 Module Failure 02
Medium	CO2 Module Failure 03	CO2 Module Failure 03
Medium	Technical Error	Technical Error 01/02/05/07/08/09
Medium	Blower Technical Error	Blower Technical Error 01/02/03
Medium	Medium Technical alarms	If the monitor shows the alarm [Medium Technical alarms], the external device may have the following alarms: CO2 Module Failure 05 Blower Fan Failure Please reset O2 sensor. Excessive Asynchrony Water accumulated in circuit? Large PEEPi
Low	Airway Leak?	Airway Leak?
Low	Battery in Use	Battery in Use
Low	Tinsp Too Long	Tinsp Too Long
Low	O2 Sensor Unconnected	O2 Sensor Unconnected
Low	Pressure Limited in Sigh cycle	Pressure Limited in Sigh cycle
Low	Volume Limited	Volume Limited
Low	Pressure Limited	Pressure Limited
Low	TV Not Achieved	TV Not Achieved
Low	Pinsp Not Achieved	Pinsp Not Achieved
Low	CO2 No Watertrap	CO2 No Watertrap
Low	Please calibrate O2 sensor	Please calibrate O2 sensor
Low	SpO2 No Pulse	SpO2 No Pulse
Low	CO2 Sensor High Temp	CO2 Sensor High Temp

Monitor output: alarms from Mindray SV300/350/600/650/800/850 ventilator		
Mindray Patient Monitor		SV300/350/600/650/800/850 Alarm
Priority	Label	Label
Low	CO2 Sampleline Occluded	CO2 Sampleline Occluded
Low	EtCO2 Overrange	EtCO2 Overrange
Low	CO2 No Sensor	CO2 No Sensor
Low	Replace HEPA Filter	Replace HEPA Filter
Low	SpO2 Sensor Off	SpO2 Sensor Off
Low	SpO2 No Sensor	SpO2 No Sensor
Low	SpO2 Too Much Light	SpO2 Too Much Light
Low	SpO2 Overrange	SpO2 Overrange
Low	PR Overrange	PR Overrange
Low	AMV:Cannot Meet Target	AMV:Cannot Meet Target
Low	Technical Error	Technical Error 04/10
Low	Low Technical alarms	If the monitor shows the alarm [Low Technical alarms], the external device may have the following alarms: Key Error Low IOC PEEP limit Low IOC O2% limit Paux1 balloon Pressure error Paux2 balloon Pressure error Storage Error

4.27.3 Output Signals - Waveforms (For BeneVision N series Monitors)

Label	Units
Paw	cmH2O, mbar, hpa
Flow	L/min
Vol	mL
CO2	%,kPa,mmHg
SpO2	/

Label	Units
Pes	cmH2O, mbar, hpa
Paux2	cmH2O, mbar, hpa
Ptp	cmH2O, mbar, hpa
Paux2-Paux1	cmH2O, mbar, hpa

4.27.4 Output Signals - Respiratory Loops (For BeneVision N series Monitors)

Label	Units
PV Loop	cmH2O/ml, hPa/ml, mbar/ml
FV Loop	L/min/ml
PF Loop	cmH2O/L/min, hPa/L/min, mbar/L/min

4.28 Mindray SynoVent E3/E5

4.28.1 Output Signals - Parameters

Monitor output: parameters from Mindray SynoVent E3/E5 ventilator			
Labels	Units	Description	Trend, record, print
Monitoring Parameters			
PEEP	cmH2O, hPa, mbar	Positive end-expiratory pressure	Yes
I:E	\	Inspiratory time: Expiratory time ratio	Yes
PR	/min	Pulse rate	Yes
SpO ₂	%	Arterial oxygen saturation from pulse oximetry	Yes
Ppeak	cmH2O, hPa, mbar	Peak pressure	Yes
Pplat	cmH2O, hPa, mbar	Plateau pressure	Yes
O ₂ %	%	Oxygen concentration	Yes
Pmean	cmH2O, hPa, mbar	Mean pressure	Yes
TVe	ml	Expiratory tidal volume	Yes
TVe spn	ml	Spontaneous expiratory tidal volume	Yes
MVe	L/min	Expiratory minute volume	Yes
MVspn	L/min	Spontaneous breathed minute volume	Yes
ftotal	/min	Total respiratory rate	Yes
fmand	/min	Mandatory breathing frequency	Yes
fspn	/min	Spontaneous respiratory rate	Yes
MV Leak	L/min	Leakage minute volume	Yes
FiO ₂	%,kPa,mmHg	Fractional concentration of O ₂ in inspired gas	Yes
Cstat	ml/cmH2O,ml/hPa,ml/mbar	Static compliance	Yes
Cdyn	ml/cmH2O,ml/hPa,ml/mbar	Dynamic compliance	Yes
RSBI	1/(min.L)	Rapid shallow breathing index	Yes

Monitor output: parameters from Mindray SynoVent E3/E5 ventilator			
Labels	Units	Description	Trend, record, print
Ri	cmH2O/L/s,hPa/L/s,mbar/L/s	Inspiratory resistance	Yes
Re	cmH2O/L/s,hPa/L/s,mbar/L/s	Expiratory resistance	Yes
NIF	cmH2O, hPa, mbar	Negative inspiratory force	No
EtCO ₂	%,kPa,mmHg	End-tidal carbon dioxide	Yes
FiCO ₂	%,kPa,mmHg	Fraction of inspired carbon dioxide	Yes
TVi	ml	Inspired tidal volume	Yes
RCexp	sec	Expiratory time constant	Yes
TVe/IBW	ml/kg,ml/lb	TVe/IBW	Yes
VCO ₂	ml/min	CO ₂ production	No
Insp Flow	L/min	Inspiration flow	Yes
P0.1	cmH2O, hPa, mbar	100 ms occlusion pressure	No
PEEPi	cmH2O, hPa, mbar	Intrinsic positive end-expiratory pressure	Yes
WOBimp	J/min	Imposed work of breathing	Yes
Setting Parameters			
PEEP	cmH2O, hPa, mbar	Positive end-expiratory pressure	No
O ₂ %	%	Oxygen concentration	No
TV	ml	Tidal volume	No
fapnea	/min	Breath rate for apnea ventilation	No
fsimv	/min	Frequency of SIMV	No
Δint. PEEP	cmH2O, hPa, mbar	Intermittent PEEP	No
F-Trig	L/min	Inspiratory trigger level (flow trigger)	No
P-Trig	cmH2O, hPa, mbar	Inspiratory trigger level (pressure trigger)	No
ΔPsupp	cmH2O, hPa, mbar	Pressure support level	No
Tinsp	sec	Time of inspiration	No

Monitor output: parameters from Mindray SynoVent E3/E5 ventilator			
Labels	Units	Description	Trend, record, print
Pinsp	cmH2O, hPa, mbar	Pressure control level of inspiration	No
Papnea	cmH2O, hPa, mbar	Apnea pressure	No
Tslope	sec	Rise time	No
Phigh	cmH2O, hPa, mbar	Upper pressure level	No
Plow	cmH2O, hPa, mbar	Lower pressure level	No
Thigh	sec	Time for the upper pressure level	No
Tlow	sec	Time for the lower pressure level	No
Exp%	%	Inspiration termination level	No
Flow	L/min	Flow	No
IBW	kg,lb	Ideal body weight	No
f	/min	Breath rate	No
Plimit	cmH2O, hPa, mbar	Pressure limit level	No
Tube ID	mm	Tube ID	No
ATC	%	Automatic Tube Compensation	No
TVApnea	ml	Apnea tidal volume	No
Tpause	%	Pause Time%	No
Cycles Sigh	/min	Sigh rate	No

4.28.2 Output Signals - Alarms

Monitor output: alarms from Mindray SynoVent E3/E5 ventilator		
Mindray Patient Monitor		SynoVent E3/E5 Alarm
Priority	Label	Label
Physiological alarms		
High	Paw High	Paw Too High
High	Paw Low	Paw Too Low
High	MV High	MV Too High

Monitor output: alarms from Mindray SynoVent E3/E5 ventilator		
Mindray Patient Monitor		SynoVent E3/E5 Alarm
Priority	Label	Label
High	MV Low	MV Too Low
High	Apnea	Apnea
High	Apnea Ventilation	Apnea Ventilation
High	FiO ₂ High	FiO2 Too High
High	FiO ₂ Low	FiO2 Too Low
High	PR High	PR Too High
High	PR Low	PR Too Low
High	SPO2 High	SpO2 Too High
High	SPO2 Low	SpO2 Too Low
High	PEEP Low	PEEP Too Low
High	PEEP High	PEEP Too High
High	Pinsp Not Achieved	Pinsp Not Achieved
High	CO2 Apnea	Apnea CO2
High	High Circuit O2	O2% Too High
High	Low Circuit O2	O2% Too Low
High	TVNot Achieved	Tidal Volume Not Achieved
High	SpO2 Desat	SpO2 Desat
High	No Pulse	No Pulse
Medium	TVe High	TVe Too High
Medium	RR High	ftotal Too High
Medium	EtCO ₂ High	EtCO2 Too High
Medium	EtCO ₂ Low	EtCO2 Too Low
Medium	TVe Low	TVe Too Low
Medium	FiCO ₂ High	FICO2 Too High
Low	Plimit Reached	Pressure Limited
Technical alarms		
High	Air Supply Pressure Low	Air Supply Pressure Low

Monitor output: alarms from Mindray SynoVent E3/E5 ventilator		
Mindray Patient Monitor		SynoVent E3/E5 Alarm
Priority	Label	Label
High	O ₂ Supply Pressure Low	O2 Supply Pressure Low O2 Supply Failure
High	No Gas Supply Pressure	No Gas Supply Pressure
High	Airway Obstructed?	Airway Obstructed?
High	Tube Disconnected?	Tube Disconnected?
High	Sustained Airway Pressure	Sustained Airway Pressure
High	Neo. Flow Sensor Failure	Neo Flow Sensor Failure
High	Insp gas temperature High	Insp. Gas Temp Too High
High	High Technical alarms	If the monitor shows the alarm [High Technical alarms], the external device may have the following alarms: RT Clock Not Exist Keyboard Comm Stop Keyboard Selftest Error Ventilator Reset Error Battery Exhaust! Syst. Down! Low Battery Voltage Ctrl Module Comm Error Ctrl Module Comm Stop Ctrl Module Selftest Error Protection Module Comm Error Protection Module Comm Stop Protection Module Selftest Err Pressure Sensor Failure Air Insp. Limb Failure Ventilator Reset Error Please perform pressure cal.
High	High Technical alarms	If the monitor shows the alarm [High Technical alarms], the external device may have the following alarms: Please perform flow cal. CO ₂ Comm Stop

Monitor output: alarms from Mindray SynoVent E3/E5 ventilator		
Mindray Patient Monitor		SynoVent E3/E5 Alarm
Priority	Label	Label
High	High Technical alarms	CO ₂ Comm Error CO ₂ Hardware Error CO ₂ Init Error CO ₂ Selftest Error Safety Valve Failure Exp. Valve Failure Device Failure 01/02/03/04/05 /06/07/08/09/12/14/15/16/17/18 19/20/21 Insp. Temp. Sensor Failure Internal Power Error Insp Valve Off Turbine Failed Turbine Temperature too high Inspiratory Module Comm Stop Expiratory Module Comm Stop Wrong Flow Sensor Type Inspiratory Module Self Test Error Expiratory Module Self Test Error Pressure Sensor Zero Error Battery 1 Temperature Abnormal. Charging Failed Battery 2 Temperature Abnormal. Charging Failed Battery 1 Charging Error Battery 2 Charging Error Battery 1 Aged Battery 2 Aged Battery 1 Comm Err

Monitor output: alarms from Mindray SynoVent E3/E5 ventilator		
Mindray Patient Monitor		SynoVent E3/E5 Alarm
Priority	Label	Label
High	High Technical alarms	Battery 2 Comm Err Battery 1 Error Battery 2 Error The machine may be powered off due to high battery temperature. Power Board Comm Stop Protective Module Initialization Error SpO2 Comm Stop The machine will be powered off soon. Connect to an external power supply. Battery Undetected Monitoring Module Initialization Error Machine Internal Voltage Error Memory Error (Machine Error 02) CO2 Module Zero Error Neo. Flow Sensor Reversed No Neo.Flow Sensor Wrong Neo.Flow Sensor Type Neo.Flow Sensor Failure Neo.Flow Sensor Overrange Blower Temperature High Blower Failure 03/04/05 Flow Sensor Type Error Blower Battery Failure 1/2/3/4/5
Medium	FiO2 Sensor Disconnected	FiO2 Sensor Disconnected
Medium	Medium Technical alarms	If the monitor shows the alarm [Medium Technical alarms], the external device may have the following alarms: Storage Card Err Key Error Battery Undetected Fan Failure Internal Temperature High Exp. Flow Sensor Failure

Monitor output: alarms from Mindray SynoVent E3/E5 ventilator		
Mindray Patient Monitor		SynoVent E3/E5 Alarm
Priority	Label	Label
Medium	Medium Technical alarms	O2 Sensor Failure O2 Insp. Limb Failure Nebulizer Valve Failure 3-way Valve Failure Replace CO2 Sensor Turbine Rotational Speed Abnormal Turbine Temp Sensor Failure Ambient Atmospheric Pressure Sensor Failure Technical Error 01 HEPA Filter Pressure Sensor Failure High battery temperature. Connect to the AC power supply. Battery too low. Connect to the AC power supply. Replace SpO2 Sensor SpO2 Init Err Inspiratory Branch Airway Obstructed Keyboard Comm Stop Keyboard Self Test Error Buzzer Error CO2 Hardware Error CO2 Init Err CO2 Self Test Error Inspiratory Temp Sensor Failure Neo Flow Sensor Disabled Blower Failure 05 Blower Fan Failure CO2 Zero Failed
Low	Airway Leak?	Airway Leak?
Low	Battery in Use	Battery in Use
Low	Tinsp Long	Tinsp Too Long
Low	CO ₂ No Water trap	CO2 No Watertrap

Monitor output: alarms from Mindray SynoVent E3/E5 ventilator		
Mindray Patient Monitor		SynoVent E3/E5 Alarm
Priority	Label	Label
Low	Low Technical alarms	<p>If the monitor shows the alarm [Low Technical alarms], the external device may have the following alarms:</p> <ul style="list-style-type: none"> RT Clock Need Reset IP Address Conflict Loading Default Config. Failed Restoring Last Config. Failed Insp. Hold Interrupted Exp. Hold Interrupted Heating Module Failure Please calibrate O2 sensor. Buzzer Failure Volume Limited CO2 Sensor High Temp CO2 Sensor Low Temp CO2 High Airway Pressure CO2 Low Airway Pressure CO2 High Barometric CO2 Low Barometric CO2 Sampleline Occluded CO2 System Error EtCO2 Overrange FICO2 Overrange Calibrate Flow Sensor. CO2 No Sensor Replace HEPA Filter Sign Cycle Pressure Limit SpO2 Sensor Off No SpO2 Sensor SpO2 Too Much Light SpO2 Non-Pulsatile SpO2 Overrange PR Overrange Key Error AMV: Cannot Meet Target

4.29 Newport E360

4.29.1 Output Signals - Parameters

Monitor output: parameters from Newport E360 ventilator			
Labels	Units	Description	Trend, record, print
Monitoring Parameters			
PEEP	cmH2O, hPa, mbar	Positive end-expiratory pressure	Yes
Ppeak	cmH2O, hPa, mbar	Peak pressure	Yes
Pmean	cmH2O, hPa, mbar	Mean pressure	Yes
TVe	ml	Expiratory tidal volume	Yes
TVi	ml	Inspired tidal volume	Yes
MVspn	L/min	Spontaneous breathed minute volume	Yes
MVe	L/min	Expiratory minute volume	Yes
MVi	L/min	Inspiratory minute volume	Yes
ftotal	/min	Total respiratory rate	Yes
fspn	/min	Spontaneous respiratory rate	Yes
I:E	\	Inspiratory time: Expiratory time ratio	Yes
FiO ₂	%,kPa,mmHg	Fractional concentration of O ₂ in inspired gas	Yes
FiO ₂ %	%	Fractional concentration of O ₂ in inspired gas	Yes
Insp Flow	L/min	Inspiration flow	Yes
Exp Flow	L/min	Expiratory flow	No
PEEPtot	cmH2O, hPa, mbar	Total PEEP	Yes
Setting Parameters			
TV	ml	Tidal volume	No
f	/min	Breath rate	No
F-Trig	L/min	Inspiratory trigger level (flow trigger)	No

Monitor output: parameters from Newport E360 ventilator			
Labels	Units	Description	Trend, record, print
P-Trig	cmH2O, hPa, mbar	Inspiratory trigger level (pressure trigger)	No
ΔPsupp	cmH2O, hPa, mbar	Pressure support level	No
Plimit	cmH2O, hPa, mbar	Pressure limit level	No
Tinsp	sec	Time of inspiration	No
PEEP/CPAP	cmH2O, hPa, mbar	PEEP/CPAP	No

4.29.2 Output Signals - Alarms

Monitor output: alarms from Newport E360 ventilator		
Mindray Patient Monitor		Newport E360 Alarm
Priority	Label	Label
Physiological alarms		
High	Paw High	High Paw
High	Paw Low	Low Paw
High	MV High	High Exhale Mv
High	MV Low	Low Exhale Mv
High	Apnea	Apnea Alarm
High	FiO ₂ High	FiO ₂ High
High	FiO ₂ Low	FiO ₂ Low
High	TV Not Achieved	Volume Target Not Met
High	High Baseline	High Baseline
High	Low Baseline	Low Baseline
High	Sustained Hbline	Sustained Hbline
Medium	RR High	Resp. Rate Alarm
Technical alarms		
High	Air Supply Pressure Low	Air Supply Loss

Monitor output: alarms from Newport E360 ventilator		
Mindray Patient Monitor		Newport E360 Alarm
Priority	Label	Label
High	O ₂ Supply Pressure Low	O2 Supply Loss
High	Check Flow Sensors	Flow Sensor Error
High	Power Failure	Power Failure
High	Tinsp too Short	Insp Time too Short
High	Patient Disconnected	Patient Disconnected
High	High Technical alarms	<p>If the monitor shows the alarm [High Technical alarms], the external device may have the following alarms:</p> <ul style="list-style-type: none"> Device Alert No O₂ Power-Up Control EEPROM Failure Low Battery Transducer Error Mon Internal System Failed Ctrol Internal System Failed Air Servo Valve Leak O₂ Servo Valve Leak Control RAM Failed Control ROM Failed Control CPU Failed Monitor RAM Failed Monitor ROM Failed Monitor CPU Failed Dual RAM Failed Monitor Tasks Failed Control Processor Failed Control Tasks Failed Monitor Processor Failed Fan Failure Air Flow Sensor EEPROM Failure O2 Flow Sensor EEPROM Failure
Medium	O ₂ and air supply	Air & O2 Supply Loss
Medium	FiO2 Sensor Disconnected	FiO2 Sensor Disconnected

Monitor output: alarms from Newport E360 ventilator		
Mindray Patient Monitor		Newport E360 Alarm
Priority	Label	Label
Medium	Medium Technical alarms	If the monitor shows the alarm [Medium Technical alarms], the external device may have the following alarms: Flow Sensor Cal Failed FiO ₂ Sensor Bad O ₂ Sensor Cal Failed External Battery Check Flow Sensor Board NO TEST
Low	Low Technical alarms	If the monitor shows the alarm [Low Technical alarms], the external device may have the following alarms: I:E Ratio Inverse violation Plimit<Pbase Psupport+Pbase>60cmH ₂ O Pbase>Low Paw Tidal Volume Out of Range Flow Out of Range Ti Out of Range Rate Out of Range Psupport Out of Range Plimit Out of Range PEEP/CPAP Out of Range Flow Trigger Out of Range CPM Blinking EXH. VALVE CAL. Failed: Prox < 1 EXH. VALVE CAL. Failed: Prox > 0.5 EXH. VALVE CAL. Failed: Prox Low EXH. VALVE CAL. Failed: Flow < 1 Leak Test Failed
Low	Tinsp too Long	Insp Time too Long
Low	Battery in Use	Battery in Use

4.30 Philips Respironics V60 (SNDA Protocol)

4.30.1 Output Signals - Parameters

Monitor output: parameters from Philips Respironics V60 (SNDA protocol) ventilator			
Labels	Units	Description	Trend, record, print
Monitoring Parameters			
ftotal	/min	Total breath rate	Yes
TVe	ml	Expiratory tidal volume	Yes
MV	L/min	Minute volume	Yes
Ppeak	cmH2O, hPa, mbar	Peak pressure	Yes
Setting Parameters			
f	/min	Breath rate	No
O ₂ %	%	Oxygen concentration	Yes
PEEP	cmH2O, hPa, mbar	Positive end-expiratory pressure	No
ΔPsupp	cmH2O, hPa, mbar	Pressure support level	No
Pinsp	cmH2O, hPa, mbar	Pressure control level of inspiration	No
Tinsp	sec	Time of inspiration	No

4.30.2 Output Signals - Alarms

Monitor output: alarms from Philips Respironics V60 (SNDA protocol) ventilator		
Mindray Patient Monitor		Respironics V60 (SNDA protocol) Alarm
Priority	Label	Label
Physiological alarms		
High	Paw High	High inhalation pressure
High	Paw Low	Low inhalation pressure Low inspiratory pressure
High	MV Low	Low exhaled minute volume Low minute volume
Medium	RR High	High respiratory rate

Monitor output: alarms from Philips Respironics V60 (SNDA protocol) ventilator		
Mindray Patient Monitor		Respironics V60 (SNDA protocol) Alarm
Priority	Label	Label
Medium	TVe Low	Low exhaled mandatory spontaneous tidal volume
Technical alarms		
High	O ₂ Supply Pressure Low	Low oxygen supply pressure
High	Patient Disconnect	Occlusion or I-time too long
High	High Technical alarms	If the monitor shows the alarm [High Technical alarms], the external device may have the following alarms: Low battery

4.31 Philips Respironics V60 (VRPT Protocol)

4.31.1 Output Signals - Parameters

Monitor output: parameters from Philips Respironics V60 (VRPT protocol) ventilator			
Labels	Units	Description	Trend, record, print
Monitoring Parameters			
ftotal	/min	Total breath rate	Yes
TVe	ml	Expiratory tidal volume	Yes
Ppeak	cmH ₂ O, hPa, mbar	Peak pressure	Yes
MVe	L/min	Expiratory minute volume	Yes
Mvleak	L/min	Leakage minute volume	Yes
TI/TTOT	\	Oxygen concentration	Yes
Setting Parameters			
f	/min	Breath rate	No
O ₂ %	%	Oxygen concentration	No
PEEP	cmH ₂ O, hPa, mbar	Positive end-expiratory pressure	No
Pinsp	cmH ₂ O, hPa, mbar	Pressure control level of inspiration	No

Monitor output: parameters from Philips Respironics V60 (VRPT protocol) ventilator			
Labels	Units	Description	Trend, record, print
Tinsp	sec	Time of inspiration	No

4.31.2 Output Signals - Alarms

Monitor output: alarms from Philips Respironics V60 (VRPT protocol) ventilator		
Mindray Patient Monitor		Respironics V60 Alarm
Priority	Label	Label
Physiological alarms		
High	Paw Low	Low inhalation pressure, Low inspiratory pressure
High	Paw High	High inhalation pressure
High	MV Low	Low exhaled minute volume Low minute volume
High	PEEP Low	Low PEEP
Medium	RR High	High respiratory rate
Medium	RR Low	Apnea
Medium	TVe Low	Low exhaled mandatory spontaneous tidal volume
Technical alarms		
High	O ₂ Supply Pressure Low	Low O ₂ supply
High	High Technical alarms	If the monitor shows the alarm [High Technical alarms], the external device may have the following alarms: Low internal battery alarm status Primary alarm failure Air source fault alarm status O ₂ valve stuck closed alarm status
High	Airway Obstructed?	Occlusion
High	EXP-VALVE?	Safety valve

Monitor output: alarms from Philips Respironics V60 (VRPT protocol) ventilator		
Mindray Patient Monitor		Respironics V60 Alarm
Priority	Label	Label
Medium	Medium Technical alarms	If the monitor shows the alarm [Medium Technical alarms], the external device may have the alarm: High enclosure temperature.
Low	Airway Leak?	High leak
Low	Low Technical alarms	If the monitor shows the alarm [Low Technical alarms], the external device may have the alarm: Nonvolatile memory failure.

4.32 Puritan Bennett PB840/PB980 (SNDF Protocol)

4.32.1 Output Signals - Parameters

Monitor output: parameters from Puritan Bennett PB840/PB980 (SNDF protocol) ventilator			
Labels	Units	Description	Trend, record, print
Monitoring Parameters			
O ₂ %	%	Oxygen concentration	Yes
EtCO ₂	%, mmHg, kPa	End-tidal carbon dioxide	Yes
PEEP	cmH ₂ O, hPa, mbar	Positive end-expiratory pressure	Yes
Ppeak	cmH ₂ O, hPa, mbar	Peak pressure	Yes
Pplat	cmH ₂ O, hPa, mbar	Plateau pressure	Yes
Pmean	cmH ₂ O, hPa, mbar	Mean pressure	Yes
TVe	ml	Expiratory tidal volume	Yes
TVi	ml	Inspired tidal volume	Yes
TVe spn	ml	Spontaneous expiratory tidal volume	Yes
MVspn	L/min	Spontaneous breathed minute volume	Yes

Monitor output: parameters from Puritan Bennett PB840/PB980 (SNDP protocol) ventilator			
Labels	Units	Description	Trend, record, print
MVe	L/min	Expiratory minute volume	Yes
ftotal	/min	Total respiratory rate	Yes
I:E	\	Inspiratory time: Expiratory time ratio	Yes
Mvleak	L/min	Leakage minute volume	Yes
Leak Comp	%	Leak compensation	No
Rstat	cmH2O/L/s,hPa/L/s,mbar/L/s	Static lung resistance	Yes
Rdyn	cmH2O/L/s,hPa/L/s,mbar/L/s	Dynamic lung resistance	Yes
Cstat	ml/cmH2O,ml/hPa,ml/mbar	Static compliance	Yes
Cdyn	ml/cmH2O,ml/hPa,ml/mbar	Dynamic compliance	Yes
RSBI	1/(min.L)	Rapid shallow breathing index	Yes
WOB	J/L	Work of breathing	Yes
NIF	cmH2O, hPa, mbar	Negative inspiratory force	No
P0.1	cmH2O, hPa, mbar	100 ms occlusion pressure	No
PEEPi	cmH2O, hPa, mbar	Intrinsic positive end-expiratory pressure	Yes
PEEPtot	cmH2O, hPa, mbar	Total PEEP	Yes
Setting Parameters			
TV	ml	Tidal volume	No
TVapnea	ml	Apnea tidal volume	No
PeakFlow	L/min	Peak flow	No
Apnea Tinsp	sec	Apnea interval	No
IBW	kg	Ideal body weight	No
Ti max	sec	Maximum inspirationtime	No
Tube ID	mm	Tube ID	No

Monitor output: parameters from Puritan Bennett PB840/PB980 (SNDF protocol) ventilator			
Labels	Units	Description	Trend, record, print
Phigh	cmH2O, hPa, mbar	Upper pressure level	No
Plow	cmH2O, hPa, mbar	Lower pressure level	No
Thigh	sec	Time for the upperpressure level	No
Tlow	sec	Time for the lowerpressure level	No
fapnea	/min	Breath rate for apnea ventilation	No
f	/min	Breath rate	No
I:E	\	Inspiratory time: Expiratory time ratio	No
Base Flow	L/min	Base Flow	No
F-Trig	L/min	Inspiratory triggerlevel (flow trigger)	No
P-Trig	cmH2O, hPa, mbar	Inspiratory trigger level (pressure trigger)	No
Δ Psupp	cmH2O, hPa, mbar	Pressure support level	No
Tplat	sec	Plateau time	No
Rise Time%	%	Rise time%	No
PEEP/CPAP	cmH2O, hPa, mbar	PEEP/CPAP	No

4.32.2 Output Signals - Alarms

Monitor output: alarms from Puritan Bennett PB840/PB980 (SNDF protocol) ventilator		
Mindray Patient Monitor		PB840/PB980 (SNDF protocol) Alarm
Priority	Label	Label
Physiological alarms		
High	MV High	High Exhaled minute Volume
High	MV Low	Low Exhaled Minute Volume
High	Apnea	Apnea

Monitor output: alarms from Puritan Bennett PB840/PB980 (SNDF protocol) ventilator		
Mindray Patient Monitor		PB840/PB980 (SNDF protocol) Alarm
Priority	Label	Label
High	FiO ₂ Low	Low O ₂ %
High	Ppeak High	High Ppeak
High	Ppeak Low	Low Ppeak
Medium	TVe High	High Exhaled Tidal Volume
Medium	RR High	High ftotal
Medium	TVe Low	Low Exhaled Mandatory Tidal Volume Alarm
Medium	EtO ₂ High	High O ₂ Percent
Technical alarms		
High	Air Supply Pressure Low	No Air Supply
High	O ₂ Supply Pressure Low	No O ₂ Supply
High	Airway Obstructed?	Severe Occlusion
High	Circuit Disconnect	Circuit Disconnect
High	Power Failure	Loss of Power
High	High Technical alarms	If the monitor shows the alarm [High Technical alarms], the external device may have the following alarms: Compressor Inoperative Compliance Limited VT Procedure Error PAV Startup Too Long PAV R& C Not Assessed Volume Not Delivered(VC+) Volume Not Delivered(VS)
Low	Low Technical alarms	If the monitor shows the alarm [Low Technical alarms], the external device may have the following alarms: Inoperative Battery Low Battery Ac Power Loss
Low	Tinsp too Long	Inspiration Too Long

4.33 Puritan Bennett PB840/PB980 (SNDA Protocol)

4.33.1 Output Signals - Parameters

Monitor output: parameters from Puritan Bennett PB840/PB980 (SNDA protocol) ventilator			
Labels	Units	Description	Trend, record, print
Monitoring Parameters			
Ppeak	cmH2O, hPa, mbar	Peak pressure	Yes
Pplat	cmH2O, hPa, mbar	Plateau pressure	Yes
Pmean	cmH2O, hPa, mbar	Mean pressure	Yes
TVe	ml	Expiratory tidal volume	Yes
MVspn	L/min	Spontaneous breathed minute volume	Yes
MVe	L/min	Expiratory minute volume	Yes
ftotal	/min	Total respiratory rate	Yes
I:E	\	Inspiratory time: Expiratory time ratio	Yes
Rstat	cmH2O/L/s, hPa/L/s, mbar/L/s	Static lung resistance	Yes
Rdyn	cmH2O/L/s, hPa/L/s, mbar/L/s	Dynamic lung resistance	Yes
Cstat	ml/cmH2O, ml/hPa, ml/mbar	Static compliance	Yes
Cdyn	ml/cmH2O, ml/hPa, ml/mbar	Dynamic compliance	Yes
NIF	cmH2O, hPa, mbar	Negative inspiratory force	No
PR	/min	Pulse rate	Yes
SpO2	%	Arterial oxygen saturation from pulse oximetry	Yes
Setting Parameters			
TV	ml	Tidal volume	No
TVapnea	ml	Apnea tidal volume	No
fapnea	/min	Breath rate for apnea ventilation	No

Monitor output: parameters from Puritan Bennett PB840/PB980 (SNDA protocol) ventilator			
Labels	Units	Description	Trend, record, print
f	/min	Breath rate	No
I:E	\	Inspiratory time: Expiratory time ratio	No
Base Flow	L/min	Base Flow	No
F-Trig	L/min	Inspiratory trigger level (flow trigger)	No
P-Trig	cmH2O, hPa, mbar	Inspiratory trigger level (pressure trigger)	No
Δ Psupp	cmH2O, hPa, mbar	Pressure support level	No
Tplat	sec	Plateau time	No
PEEP/CPAP	cmH2O, hPa, mbar	PEEP/CPAP	No
Peak Flow	L/min	Peak flow	No
Apnea Tinsp	sec	Apnea interval	No
Phigh	cmH2O, hPa, mbar	Upper pressure level	No
Plow	cmH2O, hPa, mbar	Lower pressure level	No
Cycles Sigh	/min	Sigh Rate	No
VTsigh	ml	Sigh Tidal Volume	No

4.33.2 Output Signals - Alarms

Monitor output: alarms from Puritan Bennett PB840/PB980 (SNDA protocol) ventilator		
Mindray Patient Monitor		PB840/PB980 (SNDA protocol) Alarm
Priority	Label	Label
Physiological alarms		
High	SpO2 Low	Low Saturation Alarm
High	SpO2 High	High Saturation Alarm

Monitor output: alarms from Puritan Bennett PB840/PB980 (SNDA protocol) ventilator		
Mindray Patient Monitor		PB840/PB980 (SNDA protocol) Alarm
Priority	Label	Label
High	MV Low	Low Exhaled minute Volume
High	Apnea	Apnea
High	PR Low	Low Pulse Rate Alarm
High	PR High	High Pulse Rate Alarm
High	Ppeak Low	Low Ppeak
High	Ppeak High	High Ppeak
Medium	TVe Low	Low Exhaled Mandatory Tidal Volume Alarm
Medium	RR High	High ftotal
Technical alarms		
High	Air Supply Pressure Low	No Air Supply
High	O ₂ Supply Pressure Low	No O ₂ Supply
High	EXP-VALVE?	Exhalation Valve Leak
High	Circuit Disconnect	Circuit Disconnect
Low	Low Technical alarms	If the monitor shows the alarm [Low Technical alarms], the external device may have the following alarms: Low Battery

4.34 ResMed VSIII

4.34.1 Output Signals - Parameters

Monitor output: parameters from ResMed VSIII ventilator			
Labels	Units	Description	Trend, record, print
Monitoring Parameters			
f _{total}	/min	Total respiratory rate	Yes
M _{vleak}	L/min	Leakage minute volume	Yes
Setting Parameters			
PEEP	cmH ₂ O, hPa, mbar	Positive end-expiratory pressure	No

Monitor output: parameters from ResMed VSIII ventilator			
Labels	Units	Description	Trend, record, print
TV	ml	Tidal volume	No
f	/min	Breath rate	No
F-Trig	L/min	Inspiratory trigger level (flow trigger)	No
Tinsp	sec	Time of inspiration	No
Pinsp	cmH2O, hPa, mbar	Pressure control level of inspiration	No
Exp%	%	Inspiration termination level	No
Ti max	sec	Maximum inspiration time	No

4.34.2 Output Signals - Alarms

Monitor output: alarms from ResMed VSIII ventilator		
Mindray Patient Monitor		VSIII Alarm
Priority	Label	Label
Physiological alarms		
High	Paw High	High pressure
High	Paw Low	Low Pressure
High	Apnea	Apnea alarm
Medium	RR High	High Frequency alarm
Technical alarms		
High	Power Failure	Main disconnect
High	Tube Disconnected?	Turbine alarm
High	O ₂ cell cal.Needed	FiO2 Cell Defective
High	O ₂ cell disconnect	Fi O2 Cell Missing

Monitor output: alarms from ResMed VSIII ventilator		
Mindray Patient Monitor		VSIII Alarm
Priority	Label	Label
High	High Technical Alarm	If the monitor shows the alarm [High Technical alarms], the external device may have the following alarms: No power supply Without external DC power supply Technical Alarm Internal battery temperature out of range
Medium	Patient Circuit Leak	Patient circuit disconnected
Medium	Medium Technical Alarm	If the monitor shows the alarm [Medium Technical alarms], the external device may have the following alarms: With power supply With mains power No power supply

4.35 Salvia Elisa 800/600/500/300

NOTE

- Only the Benevision N Series monitor supports integration with the Salvia Elisa 500/300 ventilator.

4.35.1 Output Signals - Parameters

Monitor output: parameters from Salvia Elisa 800/600/500/300 ventilator			
Labels	Units	Description	Trend, record, print
Monitoring Parameters			
TVe	ml	Total respiratory rate	Yes
Mve	L/min	Leakage minute volume	Yes
ftotal	/min	Total respiratory rate	Yes
O2%	%	Oxygen concentration	Yes
Ppeak	cmH2O, hPa, mbar	Peak pressure	Yes
pPlat	cmH2O, hPa, mbar	Plateau pressure	Yes
Pmean	cmH2O, hPa, mbar	Mean pressure	Yes
Pmin	cmH2O, hPa, mbar	Minimum airway pressure	No
MVspn	L/min	Spontaneous breathed minute volume	Yes
fspn	/min	Spontaneous respiratory rate	Yes
Peepi	cmH2O, hPa, mbar	Intrinsic positive end-expiratory pressure	Yes
Cdyn	ml/cmH2O,ml/hPa,ml/mbar	Dynamic compliance	Yes
Ri	cmH2O/L/s,hPa/L/s,mbar/L/s	Inspiratory resistance	Yes
TVi	ml	Inspired tidal volume	Yes
MVi	L/min	Inspiratory minute volume	Yes
PEEPe	cmH2O, hPa, mbar	Extrinsic positive end-expiratory pressure	No
PEEPtot	cmH2O, hPa, mbar	Total PEEP	Yes
P0.1	cmH2O, hPa, mbar	100 ms occlusion pressure	No

Monitor output: parameters from Salvia Elisa 800/600/500/300 ventilator			
Labels	Units	Description	Trend, record, print
FiO2%	%	Fractional concentration of O ₂ in inspired gas	Yes
EtCO2%	%	End-tidal carbon dioxide	Yes
I:E	\	Inspiratory time: Expiratory time ratio	Yes
Leak Comp	%	Leak compensation	No
PO2	kPa	oxygen supply pressure	No
WOB	J/L	Work of breathing	Yes
TVe Spn	ml	Spontaneous expiratory tidal volume	Yes
TVe/IBW	ml/kg	TVe/IBW	Yes
Tinsp	Sec	Time of inspiration	Yes
Texp	Sec	Expiratory time	Yes
RSBI	1/min-L	Rapid shallow breathing index	Yes
Pair	kPa	air supply pressure	No
RCexp	Sec	Expiratory time constant	Yes
Vtrap	ml	Trapped volume	No
RQ	\	Respiratory quotient	No
O2 Flow	L/min	O ₂ flow	No
Air Flow	L/min	Air flow	No
Setting Parameters			
TV	ml	Positive end-expiratory pressure	No
f	/min	Tidal volume	No
I:E	\	Breath rate	No
PEEP	cmH2O, hPa, mbar	Inspiratory trigger level (flow trigger)	No
Plimit	cmH2O, hPa, mbar	Time of inspiration	No
Pinsp	cmH2O, hPa, mbar	Pressure control level of inspiration	No

Monitor output: parameters from Salvia Elisa 800/600/500/300 ventilator			
Labels	Units	Description	Trend, record, print
ΔPsupp	cmH2O, hPa, mbar	Inspiratory time: Expiratory time ratio	No
Pmax	cmH2O, hPa, mbar	Pressure limit level	No
IBW	kg	Pressure support level	No
Ramp	ms	Maximum airway pressure	No
ASB Rmap	Sec	Ideal body weight	No
Tslope	Sec	Ramp	No
F-Trig	L/min	ASB ramp	No
P-Trig	cmH2O, hPa, mbar	Rise time	No
Tinsp	sec	Inspiratory trigger level (pressure trigger)	No
Tpause	%	Pause Time%	No
PASB	cmH2O, hPa, mbar	Assisted spontaneous breathing	No
Base Flow	L/min	Base Flow	No
O2%	%	Oxygen concentration	No

4.35.2 Output Signals - Alarms

Monitor output: alarms from Salvia Elisa 800/600/500/300 ventilator		
Mindray Patient Monitor		Salvia Elisa 800/600/500/300 Alarm
Priority	Label	Label
Physiological alarms		
High	Paw High	High Paw
High	Paw Low	Low Paw
High	High Paw Sustained	High Paw Sustained
High	Pmax Reached	Pmax Reached
High	Pinspired Not Achieved	Pinspired Not Achieved
High	PEEP Not Achieved	PEEP Not Achieved

Monitor output: alarms from Salvia Elisa 800/600/500/300 ventilator		
Mindray Patient Monitor		Salvia Elisa 800/600/500/300 Alarm
Priority	Label	Label
High	No Peep CPAP	No Pressure Cntrl/PEEP
High	MV Too Low	Low Mve
High	MV Too High	High Mve
High	Pressure Sustained	Pressure Limiting
High	TV Not Achieved	Vt Not Achieved
High	Volume Apnea 2 min	Volume Apnea > 2 min
High	FiO2 Too Low	Low FiO2
High	FiO2 Too High	High FiO2
Medium	SubAtmospheric Paw	Sub-Atmospheric Paw
Medium	TVe Too Low	Low Vte
Medium	TVe Too High	High Vte
Medium	Volume Apnea	Volume Apnea
Medium	RR Too Low	Low RR
Medium	RR Too High	High RR
Medium	EtCo2 Too Low	Low etCO2
Medium	EtCo2 Too High	High etCO2
Medium	FiCo2 Too High	High FiCO2
Low	Plimit Reached	Plimit Reached
Technical alarms		
High	Check flow Sensors	Check Flow Sensor
High	No Fresh Gas Flow	No Fresh Gas Flow
High	No VO2 High FiN2O	No VO2, High FiN2O
High	No O2 Pressure	No O2 Pressure
High	Negative airway pressure	Sustained Paw

Monitor output: alarms from Salvia Elisa 800/600/500/300 ventilator		
Mindray Patient Monitor		Salvia Elisa 800/600/500/300 Alarm
Priority	Label	Label
High	High Technical alarms	If the monitor shows the alarm [High Technical alarms], the external device may have the following alarms: Circuit Occluded Inspiration Stopped No Battery Low Battery Charge Low Battery (No AC) Battery deeply discharged High O2 Supply Pressure High Air Supply Pressure
Medium	Medium Technical alarms	If the monitor shows the alarm [Medium Technical alarms], the external device may have the following alarms: High Circuit O2 Low Circuit O2 No O2 Cell Sensor No Air Pressure Running On Battery Battery Failure Battery Charger Failure Fan Failure Heater Failure Power Supply Failure Display Failure Breathing System Failure Primary Audio Failure Backup Audio Failure Nebulizer Failure
Medium	Patient Circuit Leak	Patient Circuit Leak
Low	12 Hour Test	12 Hour Test

Monitor output: alarms from Salvia Elisa 800/600/500/300 ventilator		
Mindray Patient Monitor		Salvia Elisa 800/600/500/300 Alarm
Priority	Label	Label
Low	Low Technical alarms	<p>If the monitor shows the alarm [Low Technical alarms], the external device may have the following alarms:</p> <p>ASR on ARC On Replace O2 Cell O2 Cell Calibration Error No Inspiratory Flow Sensor No Expiratory Flow Sensor Patient Circuit Leak Silenced Memory (EEPROM) Failure Service Calibrations Due</p>

4.35.3 Output Signals - Waveforms (For BeneVision N series Monitors)

Label	Units
Paw	cmH2O, mbar, hpa
Flow	L/min
Vol	mL
CO2	%,kPa,mmHg
SpO2	/

4.36 SLE600 (For BeneVision N series Monitors)

4.36.1 Output Signals - Parameters

Monitor output: parameters from SLE600 ventilator			
Labels	Units	Description	Trend, record, print
Monitoring Parameters			
ftotal	/min	Total respiratory rate	Yes
CPAP	cmH2O, hPa, mbar	CPAP	Yes
Tinsp	sec	Time of inspiration	Yes
TVi	ml	Inspired tidal volume	Yes
TVe	ml	Expiratory tidal volume	Yes
PEEP	cmH2O, hPa, mbar	Positive end-expiratory pressure	Yes
Ppeak	cmH2O, hPa, mbar	Peak pressure	Yes
O2%	%	Oxygen concentration	Yes
ΔP	cmH2O, hPa, mbar	The difference between maximum and minimum pressure	Yes
Pmean	cmH2O, hPa, mbar	Mean pressure	Yes
Trigger	bpm	Number of breaths triggered by the patient in the last minute	Yes
MV	L/min	Minute volume	Yes
Leak%	%	Leak%	Yes
Rdyn	cmH2O/L/s, mbar/L/s, hPa/L/s	Dynamic lung resistance	Yes
Cdyn	ml/cmH2O, ml/mbar, ml/hPa	Dynamic compliance	Yes
C20/C	\	Compliance Ratio	Yes
DCO2		Gas transport coefficient	Yes
EtCO2	%,kPa,mmHg	End-tidal carbondioxide	Yes
PR	/min	Pulse rate	Yes
SpO2	%	Arterial oxygen saturation from pulse oximetry	Yes
PCO2	mmHg	Carbon Dioxide partial pressure	Yes

Monitor output: parameters from SLE600 ventilator			
Labels	Units	Description	Trend, record, print
PO2	mmHg	Oxygen supply pressure	No
Flow	L/min	Flow	Yes
Setting Parameters			
f	/min	Breath rate	No
CPAP	cmH2O, hPa, mbar	CPAP	No
TV	ml	Tidal volume	No
T _{insp}	sec	Time of inspiration	No
PIP	cmH2O, hPa, mbar	PIP Pressure	No
O ₂ %	%	Oxygen concentration	No
ΔP	cmH2O, hPa, mbar	The difference between maximum and minimum pressure	No
MAP	cmH2O, hPa, mbar	Mean Pressure	No
Frequency	Hz	HFO Rate	No
Sigh P	cmH2O, hPa, mbar	Pressure applied in Sigh breaths	No
Exp%	%	Inspiration termination level	No
T _{slope}	sec	Rise time	No
Flow	L/min	Flow	No

4.36.2 Output Signals - Alarms

Monitor output: alarms from SLE600 ventilator		
Mindray Patient Monitor		SLE600 ventilator Alarm
Priority	Label	Label
Physiological alarms		
High	P _{max} Reached	High Pressure Threshold Exceeded
High	P _{aw} Low	Low pressure
High	P _{aw} High	High pressure
High	Apnea	Apnea

Monitor output: alarms from SLE600 ventilator		
Mindray Patient Monitor		SLE600 ventilator Alarm
Priority	Label	Label
High	Cycle Fail	Cycle Fail
High	Continuing Positive Pressure	Continuing Positive Pressure
High	CPAP High	High CPAP
High	PEEP High	High PEEP
High	Ppeak High	High PIP
High	Ppeak Low	Low PIP
High	MV Low	Low Minute Volume
High	MV High	High Minute Volume
High	Sub Ambient Pressure	Sub Ambient Pressure
High	Pmean High	Unexpected Rise in Mean Pressure
High	Pmean Low	Unexpected Drop in Mean Pressure
High	Pressure change detected	Pressure change detected
High	ΔP High	Unexpected Rise in Delta Pressure
High	ΔP Low	Unexpected Drop in Delta Pressure
High	SpO2 Low	Low SpO2
High	SpO2 High	High SpO2
High	PR Low	Low Pulse Rate
High	PR High	High Pulse Rate
High	No Pulse	Pulse Not detected (SpO2)
Medium	RR High	High Respiratory Rate
Medium	TVe High	High Tidal Volume
Medium	TVe Low	Low Tidal Volume
Medium	No Breath Detected	Breath Not Detected
Medium	EtCO2 High	High etCO2
Medium	EtCO2 Low	Low etCO2
Medium	FiCO2 High	High CO2
Medium	FiCO2 Low	Low CO2

Monitor output: alarms from SLE600 ventilator		
Mindray Patient Monitor		SLE600 ventilator Alarm
Priority	Label	Label
Medium	High EtCO2 Spont	High EtCO2 Spont
Medium	PI Low	Low Perfusion Index (SpO2)
Technical alarms		
High	O ₂ cell cal. Needed	The oxygen cell needs calibrating
High	O ₂ Supply Pressure Low	No O ₂ Supply
High	Air Supply Pressure Low	No Air Supply
High	No Gas Supply Pressure	No Gas.
High	Power Failure	If the monitor shows the alarm [Power Failure], the external device may have the following alarms: Main Power Fail Power supply fault
High	High Technical alarms	If the monitor shows the alarm [High Technical alarms], the external device may have the following alarms: High Oxygen Level A new oxygen cell is required No SpO ₂ Sensor Connected Low Oxygen level Pressure sensor fault Monitor isolated communication error Monitor isolated system error Unable to calibrate Flow ADC Alarm system failure Hardware Fault 19 Battery low. Battery fault High Patient Leak Blocked Fresh Gas Leaking Fresh Gas

Monitor output: alarms from SLE600 ventilator		
Mindray Patient Monitor		SLE600 ventilator Alarm
Priority	Label	Label
High	High Technical alarms	<p>If the monitor shows the alarm [High Technical alarms], the external device may have the following alarms:</p> <ul style="list-style-type: none"> User interface has reset Controller system error Controller hardware error Check data output Flow Sensor Clipping Internal communication fault System Fail 101 System Fail 102 System Fail 103 System Fail 104 System Fail 105 Ventilator out of calibration Power supply error Power supply fault Monitor hardware fault UI internal communication error SpO2/etCO2 Hardware Fault
Medium	FiO2 Sensor Disconnected	O2 sensor disconnected. Please reconnect
Medium	Medium Technical alarms	<p>If the monitor shows the alarm [Medium Technical alarms], the external device may have the following alarms:</p> <ul style="list-style-type: none"> A new oxygen cell is required O2 calibration fail Calibrate Flow Sensor Unable to calibrate flow sensor Flow sensor is not connected Flow sensor is defective Flow sensor is contaminated Battery low. Flow Sensor Reversed? No etCO2 Module Connected

Monitor output: alarms from SLE600 ventilator		
Mindray Patient Monitor		SLE600 ventilator Alarm
Priority	Label	Label
Medium	Medium Technical alarms	<p>If the monitor shows the alarm [Medium Technical alarms], the external device may have the following alarms:</p> <ul style="list-style-type: none"> etCO2 Module Fault - 1 etCO2 Module Fault - 2 etCO2 Module Fault - 3 etCO2 Calibration Is Due etCO2 Maintenance Is Due No etCO2 FilterLine connected Replace etCO2 FilterLine? etCO2 Module Fault - 4 etCO2 Module Fault - 5 Invalid CO2 Value CO2 value over-range? No etCO2 Breath No SpO2 module Connected SpO2 Hardware Fault - 3 SpO2 Hardware Fault - 1 Defective SpO2 Sensor - 1 Defective SpO2 Sensor - 2 SpO2 Hardware Fault - 2 No SpO2 Cable Connected Monitor communication error O2 > 60% OxyGenie not available Oxygenie Unexpected reset No SpO2 Sensor Connected Pulse Search SpO2 Sensor Interference Detected SpO2 Sensor Off Patient Too Much Ambient Light (SpO2) Low SpO2 Signal IQ No SpO2 Adhesive Sensor Connected

5 Integrating the tcGas Monitoring Device

5.1 RADIOMETER TCM40

5.1.1 Output Signals - Parameters

Monitor output: parameters from RADIOMETER TCM40 tcGas Monitoring Device			
Labels	Units	Description	Trend, record, print
tcpCO ₂	mmHg,kPa	Transcutaneous carbon dioxide partial pressures	Yes
tcpO ₂	mmHg,kPa	Transcutaneous oxygen partial pressures	Yes
Power	mW	Sensor heating power	Yes
Tsensor	°C, °F	Sensor temperature	Yes
PR	bpm	Pulse rate	Yes
SpO ₂	%	Arterial oxygen saturation from pulse oximetry	Yes

5.1.2 Output Signals - Alarms

Monitor output: alarms from RADIOMETER TCM40 tcGas Monitoring Device		
Mindray Patient Monitor		RADIOMETER TCM40 Alarm
Priority	Label	Label
Physiological alarms		
Medium	SpO ₂ Alarm	SpO2 Alarm high/low
Medium	tcpCO ₂ Alarm	tcpCO2 Alarm high/low
Medium	tcpO ₂ Alarm	tcpO2 Alarm high/low
Medium	PR Alarm	Pulse Alarm high/low
Technical alarms		
High	tcGas Battery Depleted	Battery level critically low
High	TCM Temperature High	Monitor temperature too high
Medium	tcGas Low Battery	Battery level low
Low	TCM Alert	TCM Alert

5.2 RADIOMETER TCM4/TCM5/TCM CombiM

5.2.1 Output Signals - Parameters

Monitor output: parameters from RADIOMETER TCM4/TCM 5/TCM CombiM tcGas Monitoring Device			
Labels	Units	Description	Trend, record, print
tcpCO ₂	mmHg,kPa	Transcutaneous carbon dioxide partial pressures	Yes
tcpO ₂	mmHg,kPa	Transcutaneous oxygen partial pressures	Yes
Power	mW	Sensor heating power	Yes
Tsensor	°C, °F	Sensor temperature	Yes

5.2.2 Output Signals - Alarms

Monitor output: alarms from RADIOMETER TCM4/TCM5/TCM CombiM tcGas Monitoring Device		
Mindray Patient Monitor		RADIOMETER TCM4/TCM 5/TCM CombiM Alarm
Priority	Label	Label
Physiological alarms		
Medium	tcpCO ₂ Alarm	pCO ₂ alarm high/low
Medium	tcpO ₂ Alarm	pO ₂ alarm high/low
Technical alarms		
High	tcGas Battery Depleted	Battery level critically low
High	TCM Temperature High	Monitor temperature too high
Medium	tcGas Low Battery	Battery level low
Low	TCM Alert	TCM Alert

5.3 RADIOMETER TCM Tosca

5.3.1 Output Signals - Parameters

Monitor output: parameters from RADIOMETER TCM Tosca tcGas Monitoring Device			
Labels	Units	Description	Trend, record, print
tcpCO ₂	mmHg,kPa	Transcutaneous carbon dioxide partial pressures	Yes
Power	mW	Sensor heating power	Yes
Tsensor	°C,°F	Sensor temperature	Yes
PR	bpm	Pulse rate	Yes
SpO ₂	%	Arterial oxygen saturation from pulse oximetry	Yes

5.3.2 Output Signals - Alarms

Monitor output: alarms from RADIOMETER TCM Tosca tcGas Monitoring Device		
Mindray Patient Monitor		RADIOMETER TCM Tosca Alarm
Priority	Label	Label
Physiological alarms		
Medium	SpO ₂ Alarm	SpO2 Alarm high/low
	tcpCO ₂ Alarm	pCO2 Alarm high/low
	PR Alarm	Pulse Alarm high/low
Technical alarms		
High	tcGas Battery Depleted	Battery level critically low
	TCM Temperature High	Monitor temperature too high
Medium	tcGas Low Battery	Battery level low
Low	TCM Alert	TCM Alert

5.4 SenTec Digital Monitor

5.4.1 Output Signals - Parameters

Monitor output: parameters from SenTec Digital Monitor			
Labels	Units	Description	Trend, record, print
tcpCO ₂	mmHg,kPa	Transcutaneous carbon dioxide partial pressures	Yes
tcpO ₂	mmHg,kPa	Transcutaneous oxygen partial pressures	Yes
Power	mW	Sensor heating power	Yes
Tsensor	°C, °F	Sensor temperature	Yes
PR	bpm	Pulse rate	Yes
SpO ₂	%	Arterial oxygen saturation from pulse oximetry	Yes

5.4.2 Output Signals - Alarms

Monitor output: alarms from SenTec Digital Monitor		
Mindray Patient Monitor		SenTec Alarm
Priority	Label	Label
Physiological alarms		
High	SpO ₂ Alarm	SpO2 Alarm high/low
Medium	tcpCO ₂ Alarm	tcpCO2 Alarm high/low
	tcpO2 Alarm	tcpO2 Alarm high/low
	PR Alarm	Pulse Alarm high/low
Technical alarms		
High	tcGas Battery Depleted	SDMS Battery Critical
Medium	tcGas Low Battery	SDMS Battery Low

This page intentionally left blank.

6 Integrating Infusion System

You can connect the infusion systems to the four network connectors of the BeneLink module at the same time. Up to 24 pumps can be connected.

6.1 B.Braun Infusion Space/Perfusor Space Pumps (For BeneVision N series Monitors)

6.1.1 Output Signals - Parameters

Monitor output: parameters from B.Braun Infusion Space/Perfusor Space Pumps			
Labels	Units	Description	Trend, record, print
Rate	ml/hr	Flow Rate	No
V-infused	ml	Infused Volume	No
T-Remain	h:m	Time Remain	No
T-infused	h:m	Time Infused	No
Drug Name	\	Drug Name	No
Status	\	Infused Status	No
Mode	\	Infused Mode	No

6.1.2 Output Signals - Technical Alarms

Monitor output: alarms from B.Braun Infusion Space/Perfusor Space Pumps		
Mindray Patient Monitor		Infusion Space/Perfusor Space Alarm
Priority	Label	Label
High	Low Battery	Battery alarm
High	Syringe Empty	Syringe empty
High	Occlusion	Pressure too high

Monitor output: alarms from B.Braun Infusion Space/Perfusor Space Pumps		
Mindray Patient Monitor		Infusion Space/Perfusor Space Alarm
Priority	Label	Label
High	End of infusion	Volume infused Infusion time expired x hour limit is reached. Only for PCA operation
High	Door Open	Syringe holder open
High	Drop alarm	Drop alarm, summary of all drop alarms Drop alarm: no drops
High	Air bubble	Air alarm, summary of all air alarms Air alarm: Air bubble too large > 0.3 ml Air alarm: Air rate exceeded > 4 ml/h Air alarm: sensor test faulty
High	Syringe Near Empty	syringe empty pre-alarm

6.2 Carefusion Alaris GW/GH/PK/CC/CGW/CGH Infusion Management System (For BeneVision N Series Monitors)

6.2.1 Output Signals - Parameters

Monitor output: parameters from Carefusion Alaris Infusion Management System			
Labels	Units	Description	Trend, record, print
Rate	ml/h	Flow Rate	No
V-infused	ml	Infused Volume	No
T-Remain	min	Left Time	No
Status	/	Infused status	No

6.2.2 Output Signals - Technical Alarms

Monitor output: alarms from Carefusion Alaris Infusion Management System		
Mindray Patient Monitor		Carefusion Alaris Alarm
Priority	Label	Label
High	Syringe Disengagement	Drive Disengaged
High	KVO Done	End Of Infusion-KVO
High	End Of Infusion	End Of Infusion-Stop
High	Low Battery	Battery Exhaust
		Low Battery at Power-on
		Low Battery
High	Infusion Near Done	Near End of Infusion
High	Occlusion	Occlusion

6.3 Fresenius Agilia Injectomat Series Infusion Pumps (For BeneVision N series Monitors)

6.3.1 Output Signals - Parameters

Monitor output: parameters from Fresenius Agilia Injectomat series Infusion Pumps			
Labels	Units	Description	Trend, record, print
Rate	ml/hr	Flow Rate	No
V-infused	ml	Infused Volume	No
Drug Name	\	Drug Name	No
VTBI	ml	Left Volume	No

6.3.2 Output Signals - Technical Alarms

Monitor output: alarms from Fresenius Agilia Injectomat series Infusion Pumps		
Mindray Patient Monitor		Agilia Injectomat Alarm
Priority	Label	Label
High	Low Battery	Battery/Pre-Alarm Battery
High	End of infusion	end of limit volume end of volume/time end of infusion
High	Occlusion	occlusion rise of pressure
High	Mechanical Abnormal	syringe clamp flange plunger head
High	Syringe disengagement	disengagement
High	Drop too less	infusion flow rate low
High	Drop too many	infusion flow rate high
High	Syringe Empty	syringe empty
Medium	Pre-Occlusion	occlusion(pre-alarm)
Medium	System Abnormal	power disconnection
Low	Infusion Near Done	end of limit volume (pre-alarm) end of volume/time(pre-alarm) end of infusion (pre-alarm)

6.4 Fresenius Agilia Volumat Series Infusion Pumps (For BeneVision N series Monitors)

6.4.1 Output Signals - Parameters

Monitor output: parameters from Fresenius Agilia Volumat series Infusion Pumps			
Labels	Units	Description	Trend, record, print
Rate	ml/hr	Flow Rate	No
V-infused	ml	Infused Volume	No
Drug Name	\	Drug Name	No
VTBI	ml	Left Volume	No

6.4.2 Output Signals - Technical Alarms

Monitor output: alarms from Fresenius Agilia Volumat series Infusion Pumps		
Mindray Patient Monitor		Agilia Volumat Alarm
Priority	Label	Label
High	Low Battery	battery alarm battery pre-alarm
High	end of infusion	end of infusion alarm end of secondary infusion alarm
High	Occlusion	downstream occlusion alarm upstream occlusion alarm occlusion detected by drop sensor occlusion check system failed pressure increase
High	Mechanical Abnormal	clamp missing
High	Syringe disengagement	Disengagement
High	Sensor alarm	absence of drop sensor presence of drop sensor
High	Drop too less	under flow alarm detected by drop sensor low flow rate or low dose
High	Drop too many	over flow alarm detected by drop sensor high flow rate or high dose

Monitor output: alarms from Fresenius Agilia Volumat series Infusion Pumps		
Mindray Patient Monitor		Agilia Volumat Alarm
Priority	Label	Label
High	Syringe Empty	Syringe empty
High	Door Open	door opened alarm
High	Drop alarm	uncontrolled flow alarm
High	Air bubble	Air alarm (air presence or air detection failure) Air alarm (air volume exceeded limit)
Medium	Pre-Occlusion	downstream occlusion pre-alarm
Medium	System Abnormal	set not detected by upstream pressure sensor set not detected by downstream pressure sensor set not installed correctly main disconnection
Low	Infusion Near Done	end of infusion pre-alarm

6.5 Fresenius Base Intensive/Base Primea Infusion Management System (For BeneVision N Series Monitors)

6.5.1 Output Signals - Parameters

Monitor output: parameters from Fresenius Base Intensive/Base Primea Infusion Management System			
Labels	Units	Description	Trend, record, print
Rate	ml/h	Flow Rate	No
V-infused	ml	Infused Volume	No
Drug Name	/	Drug Name	No
VTBI	ml	Volume to be Infused	No
Status	/	Infused status	No
Mode	/	Infused Mode	No

6.5.2 Output Signals - Technical Alarms

Monitor output: alarms from Fresenius Base Intensive/Base Primea Infusion Management System		
Mindray Patient Monitor		Base Intensive/Base Primea Alarm
Priority	Label	Label
High	Door open	Syringe flange clasp
		Door open
High	Mechanical Abnormal	lunger head
		Flanges
		Tube missing
		Clamp missing
High	Occlusion	Occlusion
		Raising of occlusion in progress on other module
High	Syringe disengagement	Disengagement
High	End of infusion	End of infusion
High	Battery Low	Battery
High	Air Bubble	Air Bubble
		Presence of air
High	Drop alarm	Drop detector missing
		Under flow
		Over flow
		Free flow
Prompt	End of infusion	End of infusion
Prompt	Occlusion	Occlusion
Prompt	Battery Low	Battery

6.6 MedimaNet Server Infusing Monitoring and Archiving Network System (For BeneVision N series Monitors)

6.6.1 Output Signals - Parameters

Monitor output: parameters from MedimaNet Server Infusing Monitoring and Archiving Network System			
Labels	Units	Description	Trend, record, print
Rate	ml/hr	Flow rate	Yes
T-infused	h:m	Acculated infusion time	Yes
DrugName	\	Drug name	No
Status	\	Pump connection status	No

6.7 Mindray BeneFusion DS5(VP5/SP5/SP5 TCI/SP5 DTCl) Pumps (For BeneVision N series Monitors)

6.7.1 Output Signals - Parameters

Monitor output: parameters from Mindray BeneFusion DS5 Series Infusion Supervision system			
Labels	Units	Description	Trend, record, print
Rate	ml/hr	Flow Rate	No
V-infused	ml	Infused Volume	No
Drug Name	\	Drug name	No
VTBI	ml	Volume To Be Infused	No
T-Infused	h:m:s	Infused Time	No
T-Remain	h:m:s	Left Time	No
Status	\	Infused status	No
Mode	\	Infused Mode	No

6.7.2 Output Signals - Technical Alarms

Monitor output: alarms from Mindray BeneFusion DS5 Infusion Supervision system		
Mindray Patient Monitor		BeneFusion DS5 Alarm
Priority	Label	Label
High	Low Battery	battery Exhausted Battery Low
High	end of infusion	Over
High	Occlusion	Occlusion Top Occlusion
High	System Error	System Error
High	Syringe Disengagement	Dislocated Not Install
High	Empty	Empty
High	Syringe Empty	Empty Empty Bottle
High	Door Open	Door Open
High	Drop alarm	Drip UnExptional
High	Air bubble	Air Bubble
High	KVO Done	KVO Done
Med	System Abnormal	System Failure System Exceptional
Low	Infusion Near Done	Near over
Low	Syringe Near Empty	Near Empty

6.8 Mindray BeneFusion nDS/nVP/nSP Pump (For BeneVision N series Monitors)

NOTE

- For more parameters, enter the Infusion Details screen.

6.8.1 Output Signals - Parameters

Monitor output: parameters from Mindray BeneFusion nDS/nVP/nSP pumps		
Labels	Description	Trend, record, print
Status	Infused status	No
Rate	Flow rate	No
DrugName	Drug name	No
Mode	Infused Mode	No
V-Infused	Infused Volume	No
VTBI	Left Volume	No
T-Infused	Acculated infusion Time	No
T-Remain	Left Time	No
Dose Rate	Dose Speed	No
Conc.	Drug Concentration	No
Intmt. Vol.	Cur stage remain vol	No
Intmt. Time	Intmt. Time	No
Loading Rate	Loading Rate	No
Loading Time	Loading Time	No
Loading Dose	Loading Dose	No
Up Rate	Up Rate	No
Up VTBI	Up VTBI	No
Up Time	Up Time	No
Volume	Volume	No
Next Stage VTBI	Next Stage VTBI	No
Cpt	Cpt	No

Monitor output: parameters from Mindray BeneFusion nDS/nVP/nSP pumps		
Labels	Description	Trend, record, print
Cp	Cp	No
ce	ce	No
Awake Time	Awake Time	No
Cet	Cet	No
Time	Time	No
LockTime	Lock Time	No
Effective/Actual	Effective/Actual	No
Induction Dose	Induce dose	No
Induction Rate	Induce speed	No
Induction Time	Induce time	No
MaintainDoseRate	Maintence dose speed	No
Maintain Rate	Maintain speed	No
Primary Rate	Primary speed	No
Steady Rate	Steady speed	No
Steady VTBI	Steady VTBI	No
Steady Time	Steady Time	No
Down VTBI	Down VTBI	No
Down Time	Down Time	No
Down Rate	Down speed	No
Total VTBI	Total VTBI	No
BolusRate	Bolus speed	No
Bolus volume	Bolus volume	No
BolusVTBI	BolusVTBI	No
BolusTime	BolusTime	No
Bolus Dose	Bolus Dose	No

6.8.2 Output Signals - Technical Alarms

Monitor output: alarms from Mindray BeneFusion nDS/nVP/nSP pump		
Mindray Patient Monitor		BeneFusion nDS/nVP/nSP Alarm
Priority	Label	Label
High	No Drop Sensor	No Drop Sensor
High	No Syringe	No Syringe
High	No Infusion Tube	No Infusion Tube
High	Battery Depleted	Battery Depleted
High	Air bubble	Air bubble
High	Accumulated Air	Accumulated Air
High	Empty	Empty
High	Drop Error	Drop Error
High	Upstream Occlusion	Upstream Occlusion
High	Downstream Occlusion	Downstream Occlusion
High	Occlusion	Occlusion Top Occlusion
High	VTBI Complete	VTBI Complete
High	KVO Done	KVO Done
High	Syringe Empty	Empty Empty Bottle
High	Syringe disengagement	Dislocated Not Instal
High	Pluggger Grippers Error	Pluggger Grippers Error
High	Relay Invalid	Relay Invalid
High	Infusion Set Disengaged	Infusion Set Disengaged
High	Infusion Set Error	Infusion Set Error
High	System Error	System Error
High	PCA Cable Detached	PCA Cable Detached
High	Secondary VTBI Completed	Secondary VTBI Completed

Monitor output: alarms from Mindray BeneFusion nDS/nVP/nSP pump		
Mindray Patient Monitor		BeneFusion nDS/nVP/nSP Alarm
Priority	Label	Label
Low	KVO Running	KVO Running
Low	Battery in Use	Battery in Use
Low	Battery Error	Battery Error
Low	Standby Time Expired	Standby Time Expired
Low	System Time Error	System Time Error
Low	Extension Line Detached	Extension Line Detached
Low	Relay Invalid Soon	Relay Invalid Soon
Low	Slave Controller Abnormal	Slave Controller Abnormal
Low	Low Battery	Low Battery
Low	Battery Error	Battery Error
Low	Infusion Near Done	Infusion Near Done
Low	Syringe Near Empty	Syringe Near Empty
Low	Reminder	Reminder
Prompt	Pressure increasing.Occlusion?	Pressure increasing.Occlusion?

This page intentionally left blank.

7 Integrating Other Devices

7.1 Baxter Prismaflex/ PrisMax Hemodialysis (For BeneVision N Series Monitors)

7.1.1 Output Signals - Parameters

Monitor output: parameters from BaxterPrismaflex hemodialysis			
Labels	Units	Description	Trend, record, print
Monitoring Parameters			
Access P	mmHg	access pressure	No
Filter P	mmHg	filter pressure	No
Effluent P	mmHg	effluent pressure	No
Return P	mmHg	return pressure	No
TMP	mmHg	transmembrane pressure	No
DP	mmHg	pressure drop	No
Blood Vol	L	actual blood volume processed	Yes
Pre NoPBP	ml	actual cumulated volume for replacement PRE (excluding PBP)	Yes
Post Repl	ml	Total Replacement volume Post delivered.	Yes
Dial	ml	actual cumulated volume for dialysate.	Yes
PBP	ml	actual cumulated volume for pre-blood.	Yes
Effl	ml	actual cumulated volume for effluent.	Yes
PFR	ml	actual cumulated volume for patient fluid removal.	Yes
Fluid Sign	ml	signed actual value for patient excess fluid loss or gain, in CRRT.	Yes

Monitor output: parameters from BaxterPrismaflex hemodialysis			
Labels	Units	Description	Trend, record, print
Syringe	ml	actual cumulated volume for infused syringe solution	Yes
R PBP Dose	ml/kg/h	Total Replacement (incl Pre Blood Pump) dose	Yes
Fluid 1H	ml	FLUID 1H	Yes
Setting Parameters			
Blood	ml/min	blood flow	No
Repl Pre	ml/h	replacement pre flow	No
Repl Post	ml/h	replacement post flow	No
Dialysate	ml/h	dialysate flow	No
Pre Blood	ml/h	pre-blood flow	No
Effl Flow	ml/h	effluent flow	No
Fluid Rem.	ml/h	Patient fluid removal flow	No
Filt Fract	%	Calculated Filtration fraction value	No
Post Hct	%	Post-filter Hematocrit	No
UFR	ml/kg/h	UFR	No
Effl Dose	ml/kg/h	EFFL DOSE	No

7.1.2 Output Signals - Technical Alarms (Baxter Prismaflex)

Monitor output: alarms from Baxter Prismaflex Hemodialysis		
Mindray Patient Monitor		Baxter Prismaflex Hemodialysis Alarm
Priority	Label	Label
High	Air in Blood	Air in Blood
High	Return Disconnection	Return Disconnection
High	Return Pressure Dropping	Return Pressure Dropping
High	Set Disconnection	Set Disconnection

Monitor output: alarms from Baxter Prismaflex Hemodialysis		
Mindray Patient Monitor		Baxter Prismaflex Hemodialysis Alarm
Priority	Label	Label
High	Filter Clotted	Filter Clotted
High	Plasmafilter Clotted	Plasmafilter Clotted
High	HP Cartridge Clotted	HP Cartridge Clotted
High	Blood Leak Detected	Blood Leak Detected
High	Return Extremely Positive	Return Extremely Positive
High	Return Extremely Positive No Recovery	Return Extremely Positive No Recovery
High	Access Extremely Negative	Access Extremely Negative
High	Access Extremely Negative No Recovery	Access Extremely Negative No Recovery
High	Access Extremely Positive	Access Extremely Positive
High	Filter Extremely Positive	Filter Extremely Positive
High	Power Failure	Power Failure
High	Low Battery	Battery Low
High	Unsuitable Ca Solution	Unsuitable Ca Solution
High	Effluent line not in BLD	Effluent line not in BLD
High	Fluid Leak Detected	Fluid Leak Detected
High	Syringe Plunger Not Secured	Syringe Plunger Not Secured
High	Lines Not Clamped	Lines Not Clamped
High	Clamp Stuck Closed	Clamp Stuck Closed
High	Blood Pump Rate Wrong	Blood Pump
High	Effluent Pump Rate Wrong	Effluent Pump
High	Replacement Pump Rate Wrong	Replacement Pump
High	Dialysate Pump Rate Wrong	Dialysate Pump

Monitor output: alarms from Baxter Prismaflex Hemodialysis		
Mindray Patient Monitor		Baxter Prismaflex Hemodialysis Alarm
Priority	Label	Label
High	PBP Pump Rate Wrong	PBP Pump
High	High Technical Alarm	<p>If the monitor shows the alarm (High Technical Alarm), the external device may have the alarms :</p> <p>ALMW_W_BAG_FULL_PRIME ALMW_D_BAG_EMPTY_PRIME ALMW_R_BAG_EMPTY_PRIME ALMW_P_BAG_EMPTY_PRIME ALMW_R_INCORRECT_PRIME_BAG_VOLUME ALMW_D_INCORRECT_PRIME_BAG_VOLUME ALMW_W_INCORRECT_PRIME_BAG_VOLUME ALMW_P_INCORRECT_PRIME_BAG_VOLUME ALMW_R_PRIME_SCALE_OPEN ALMW_D_PRIME_SCALE_OPEN ALMW_W_PRIME_SCALE_OPEN ALMW_P_PRIME_SCALE_OPEN ALMW_PRIME_LINE_PPI_CLAMPED ALMW_PRIME_LINE_D_CLAMPED ALMW_PRIME_LINE_REP_CLAMPED ALMW_PRIME_LINE_RETURN_CLAMPED ALMW_PRIME_LINE_EFFLRET_CLAMPED ALMW_PRIME_SYRINGE_LINE_CLAMPED ALMW_PRIME_SYRINGE_EMPTY ALMW_RIC_TIME_ELAPSED ALMW_TOO_WEIGHT_PUMP_ALM ALMW_EFFLUENT_PRIME_BAG_VOLUME ALMW_SETUP_ERROR</p>

Monitor output: alarms from Baxter Prismaflex Hemodialysis		
Mindray Patient Monitor		Baxter Prismaflex Hemodialysis Alarm
Priority	Label	Label
High	High Technical Alarm	<p>If the monitor shows the alarm [High Technical Alarm], the external device may have the alarms:</p> <p>ALMW_LINE_CROSSED_PBP_DIAL_PRIME ALMW_LINE_CROSSED_PBP_REP_PRIME ALMW_LINE_CROSSED_DIAL_REP_PRIME ALMW_LINE_CROSSED_PBP_DIAL_REP_PRIME ALMW_LINE_CROSSED_PBP_REP2_PRIME ALMW_LINE_CROSSED_REP_REP2_PRIME ALMW_LINE_CROSSED_PBP_REP_REP2_PRIME ALMW_BP_SEG_SIZE_LF_DETECTED_PRIME ALMW_BP_SEG_SIZE_HF_DETECTED_PRIME ALMW_INCORRECT_DISPOSABLE_BARCODE ALMW_INCORRECT_DISPOSABLE_RECOGNITION ALMW_PRIME_CALCIIUM_SYRINGE_EMPTY ALMW_PRIME_CALCIIUM_LINE_CLAMPED ALMW_PRIME_CALCIIUM_LINE_NOT_CONNECTED ALMW_PINCH_VALVES_POS_INCORRECT_LOAD ALMW_PINCH_VALVES_POS_INCORRECT_UNLOAD ALMM_GENERAL_SAFESTATE_UNDEFINED ALMM_WATCHDOG_FAIL_ON_TASK ALMM_PROT_COMMUNICATION_LINK_ERROR ALMM_CON_COMMUNICATION_LINK_ERROR ALMM_STATUS_COMM_MISSING ALMM_ALARM_COMM_MISSING ALMM_SENDDTOPSLAVE_ERROR ALMM_SETVAL_INCONGRUENCE ALMM_PRESSURE_HWTEST_FAIL ALMM_VOLTAGE_OUT_RANGE ALMM_SETVAL_INCONGRUENCE_CTRL_PROT ALMM_BUBBLE_TEST_FAIL ALMM_BLD_NORM_FAIL ALMM_BLOOD_TEST_FAIL ALMM_STST_ACC_EFFL_FAIL ALMM_STST_FIL_EFFL_FAIL ALMM_STST_EFFL_FIL_ACC_FAIL ALMM_STST_RET_FAIL ALMM_PRTST_BLDNORM_FAIL ALMM_PRTST_BLD_FAIL</p>

Monitor output: alarms from Baxter Prismaflex Hemodialysis		
Mindray Patient Monitor		Baxter Prismaflex Hemodialysis Alarm
Priority	Label	Label
High	High Technical Alarm	<p>If the monitor shows the alarm [High Technical Alarm], the external device may have the alarms:</p> <p>ALMM_PRTST_STOPPUMP_FAIL ALMM_PRTST_PUMPOCCL_FAIL ALMM_PRTST_DIAL_PINCH_FAIL ALMM_PRTST_REP_PINCH_FAIL ALMM_PRTST_DIALREP_PINCH_FAIL ALMM_PRTST_24V_FAIL ALMM_PRTST_CLAMP_FAIL ALMM_PRTST_24V_CLAMP_FAIL ALMM_PRTST_ACC_FAIL ALMM_PRTST_FIL_FAIL ALMM_PRTST_ACC_FIL_FAIL ALMM_PRTST_EFFL_FAIL ALMM_PRTST_ACC_EFFL_FAIL ALMM_PRTST_FIL_EFFL_FAIL ALMM_PRTST_EFFL_FIL_ACC_FAIL ALMM_PRTST_RET_FAIL ALMM_SYRINGE_PUMP_CONTROL ALMM_DIFFERING_WEIGHTS_REPLACE ALMM_DIFFERING_WEIGHTS_DIALYSATE ALMM_DIFFERING_WEIGHTS_PPI ALMM_DIFFERING_WEIGHTS_EFFLUENT ALMM_PRESS_ZERO_TEST_FAIL ALMM_SCALE_ZERO_TEST_FAIL ALMM_ERROR_DATA_SAVED_IN_CUSTOM ALMM_NO_ALIGN_ON_LIBRARY_DATA ALMM_NO_ALIGN_ON_CUSTOM_DATA ALMM_DATA_ERROR ALMM_SETVAL_BAD_CRC ALMM_CO_INCONGRUENT_INFO ALMM_LINE_IN_CLAMP ALMM_NO_LINE_IN_ABD</p>

Monitor output: alarms from Baxter Prismaflex Hemodialysis		
Mindray Patient Monitor		Baxter Prismaflex Hemodialysis Alarm
Priority	Label	Label
High	High Technical Alarm	<p>If the monitor shows the alarm [High Technical Alarm], the external device may have the alarms:</p> <p>ALMM_LINE_IN_ABD ALMM_DIAL_PINCH_WRONG ALMM_REP_PINCH_WRONG ALMM_SCALE_HWTEST_FAIL ALMM_SYRINGE_HWTEST_FAIL ALMM_SCALE_EFFLENS_FAIL ALMM_SCALE_REPLENS_FAIL ALMM_SCALE_DIALSENS_FAIL ALMM_SCALE_PBPSSENS_FAIL ALMM_NO_LINE_IN_CLAMP ALMM_SYRINGE_NOT_LOADED ALMM_R2_RATE_WRONG ALMM_SYRINGE_PUMP_RATE ALMM_SYRINGE_PUMP_DIRECTION ALMM_SYRINGE_PUMP_CONFIG ALMM_SYRINGE_PUMP_SENSOR ALMM_SYRINGE_PUMP_FORCEHIGH ALMM_SYRINGE_PUMP_FORCELOW ALMM_SYRINGE_PUMP_MOVING ALMM_SYRINGE_PUMP_NOTMOVING ALMM_BACKUP_MEMORY_PTASK_AC ALMM_GENERAL_SAFESTATE_ALL_PUMPS ALMM_GENERAL_SAFESTATE_FLUID_PUMPS ALMM_GENERAL_SAFESTATE_CLOSE_CLAMP ALMM_GENERAL_SAFESTATE_PS_CRIT_CNT ALMM_GENERAL_SAFESTATE_I2C_RETRY_CNT ALMM_GENERAL_SAFESTATE_SYRINGE_PUMP ALMM_TOO_HIGH_AUTO_BLOOD_RETURN ALMM_STST_SOUNDCHECK_FAILED ALMM_SOUNDCHECK_FAILED ALMM_GENERAL_SAFESTATE_PS_REBOOTS ALMM_PRTST_TMPA_CAL_FAIL ALMM_DATA_PROBLEM</p>

Monitor output: alarms from Baxter Prismaflex Hemodialysis		
Mindray Patient Monitor		Baxter Prismaflex Hemodialysis Alarm
Priority	Label	Label
Medium	Medium Technical Alarm	<p>If the monitor shows the alarm [Medium Technical Alarm], the external device may have the alarms:</p> <p>ALMC_W_BAG_FULL ALMC_D_BAG_EMPTY ALMC_R_BAG_EMPTY ALMC_R_TPE_BAG_EMPTY ALMC_P_BAG_EMPTY ALMC_R_INCORRECT_BAG_VOLUME ALMC_D_INCORRECT_BAG_VOLUME ALMC_W_INCORRECT_BAG_VOLUME ALMC_P_INCORRECT_BAG_VOLUME ALMC_R_SCALE_OPEN ALMC_D_SCALE_OPEN ALMC_W_SCALE_OPEN ALMC_P_SCALE_OPEN ALMC_EFFLUENT_BAG_VOLUME ALMC_D_FIX_BAG_EMPTY ALMC_R_FIX_BAG_EMPTY ALMC_P_FIX_BAG_EMPTY ALMC_EXCESS_PATIENT_FLUID ALMC_ANTICOAG_SUSPENDED ALMC_FLUID_LEAK_DETECTED ALMC_DIA_ON_CLIPPING ALMC_REP2_ON_CLIPPING ALMC_EFF_CONTROL_ERROR ALMC_REP_CONTROL_ERROR ALMC_PBP_CONTROL_ERROR ALMC_DIA_CONTROL_ERROR ALMC_REP2_CONTROL_ERROR ALMC_FLUID_LEAK_DETECTED</p>

Monitor output: alarms from Baxter Prismaflex Hemodialysis		
Mindray Patient Monitor		Baxter Prismaflex Hemodialysis Alarm
Priority	Label	Label
Medium	Flow Problem	If the monitor shows the alarm (Flow Problem) , the external device may have the alarms : ALMC_TOO_WEIGHT_PUMP_ALM ALMC_W_INCORRECT_CHANGE ALMC_R_INCORRECT_CHANGE ALMC_PPL_INCORRECT_CHANGE ALMC_D_INCORRECT_CHANGE ALMC_TPE_PRESCRIPTION ALMC_R2_INCORRECT_CHANGE ALMC_EFF_ON_CLIPPING ALMC_REP_ON_CLIPPING ALMC_PBP_ON_CLIPPING
Medium	TMP Excessive	TMP Excessive
Medium	TMPa Excessive	TMPa Excessive
Medium	Patient Fluid Gain Excessive	Patient Fluid Gain Excessive
Low	Low Technical Alarm	If the monitor shows the alarm [Low Technical Alarm], the external device may have the alarms: ALMA_ACC_PRESS_OVER_OP ALMA_ACC_PRESS_UNDER_OP ALMA_RET_PRESS_OVER_OP ALMA_PAUSE_TIME_EXPIRED ALMA_SYRINGE_EMPTY ALMA_SYRINGE_LINE_CLAMPED ALMA_CLOTTING_FILTER ALMA_TPE_CLOTTING_FILTER ALMA_HP_CLOTTING_FILTER ALMA_MAX_UFR ALMA_TPE_MAX_UFR ALMA_REPLACE_BLOOD_CIRCUIT ALMA_RET_PRESS_CANNOT_MON ALMA_CONFIRM_POSITIVE_RANGE ALMA_CONFIRM_NEGATIVE_RANGE ALMA_CONFIRM_CONFIRM_POSITIVE_RANGE ALMA_SYRINGE_LINE_CLAMPED_TEST

Monitor output: alarms from Baxter Prismaflex Hemodialysis		
Mindray Patient Monitor		Baxter Prismaflex Hemodialysis Alarm
Priority	Label	Label
Low	Low Technical Alarm	If the monitor shows the alarm [Low Technical Alarm], the external device may have the alarms: ALMA_SYRINGE_NOT_LOADED ALMA_FLUID_PUMPS_STOPPED ALMA_CITRATE_CHECK_POINT ALMA_SYRINGE_ALMOST_EMPTY ALMA_CALCIIUM_SYRINGE_EMPTY ALMA_CALCIIUM_LINE_CLAMPED ALMA_CALCIIUM_LINE_NOT_CONNECTED ALMA_MEMORY_BACKUP ALMA_START_MARS_TREATMENT ALMA_BATTERY_EXHAUSTED B ALMA_MAIN_POWER_LOST ALMA_SELF_TEST_OVERDUE ALMA_INCOMPLETE_BOLUS ALMA_CHECK_OXYGEN_SUPPLY ALMA_STORAGE_NOT_READY

7.1.3 Output Signals - Technical Alarms (Baxter PrisMax)

Monitor output: alarms from Baxter PrisMax Hemodialysis		
Mindray Patient Monitor		Baxter PrisMax Hemodialysis Alarm
Priority	Label	Label
High	Return Disconnection	Return Disconnection
High	Return Extremely Negative	Return Extremely Negative
High	Return Extremely Positive	Return Extremely Positive
High	Access Extremely Negative	Access Extremely Negative
High	Access Extremely Positive	Access Extremely Positive

Monitor output: alarms from Baxter PrisMax Hemodialysis		
Mindray Patient Monitor		Baxter PrisMax Hemodialysis Alarm
Priority	Label	Label
High	Set Disconnection	Set Disconnect
High	Air in Blood	Air Detected in Blood
High	Blood Leak Detected	Blood Leak
High	High Filter Pressure	High Filter Pressure
High	Change Set	Change Set
High	Unsuitable Ca Solution	Unsuitable Calcium Solution
High	High Technical Alarm	If the monitor shows the alarm [High Technical Alarm], the external device may have the alarms: Total Loss of Power Return Line Not in Clamp Deaeration Chamber Missing No Line in Air Detector Return test not attached Return Clamp Not Opened Return Barrier May Be Wet Return Test Line Clamped Filter Test Line Clamped Access Test Line Clamped Return Clamp Not Closed Effluent Bag Weight Increase
High	High Technical Alarm	If the monitor shows the alarm [High Technical Alarm], the external device may have the alarms: Anticoagulation Suspended Communications Lost Call Service TherMax Arm Position Disposable TherMax Open Effluent Drain Weight Increase
Medium	TMP Excessive	TMP Pressure Excessive
Medium	TMPa Excessive	TMPa Pressure Excessive
Medium	Patient Fluid Gain Excessive	Patient PBP Fluid Gain Excessive

Monitor output: alarms from Baxter PrisMax Hemodialysis		
Mindray Patient Monitor		Baxter PrisMax Hemodialysis Alarm
Priority	Label	Label
Medium	Flow Problem	Flow Problem
Medium	Membrane Pressure Excessive	Membrane Pressure Excessive
Medium	Medium Technical Alarm	<p>If the monitor shows the alarm [Medium Technical Alarm], the external device may have the alarms:</p> <ul style="list-style-type: none"> Cannot Monitor Return Syringe Line Clamped Check Syringe Line Return Clamp Not Closed CRRT Gain/Loss Limit Reached PBP Bag Not Mixed Blood Leak Detected BLD Normalization Failure Syringe Pump Out of Order Battery Temperature Problem Set did not load correctly Check Access Return Low Operating Point Replacement 2 Bag Not Mixed Replacement Bag Not Mixed Dialysate Bag Not Mixed CRRT Maximum Set Life Exceeded HP Maximum Set Life Exceeded

Monitor output: alarms from Baxter PrisMax Hemodialysis		
Mindray Patient Monitor		Baxter PrisMax Hemodialysis Alarm
Priority	Label	Label
Medium	Medium Technical Alarm	<p>If the monitor shows the alarm [Medium Technical Alarm], the external device may have the alarms:</p> <ul style="list-style-type: none"> TPE Maximum Set Life Exceeded Patient High Voltage Syringe Force Overload Scale Calibration Temperature - Large Delta Access pod not attached Effluent pod not attached Filter pod not attached Return Line Clamped Access Line Clamped Effluent Test Line Clamped Rep Weight Increase Rep2 Weight Increase PBP Weight Increase Effluent Bag Weight Increase Auto Effluent (AE) Maximum Set Life Reached PBP Excessive Weight Error Replacement Excessive Weight Error Effluent Excessive Weight Error TherMax Malfunction TherMax Disposable Unlocked TherMax Not Level
Low	Blood Flow Stopped	Blood Flow Stopped
Low	Membrane Pressure Rising	Membrane Pressure Rising
Low	Return Extremely Positive	Return Extremely Positive
Low	Flow Problem	<p>If the monitor shows the alarm [Flow Problem], the external device may have the alarms:</p> <ul style="list-style-type: none"> Low Effluent Flow Rate Low Front Effluent Drain Flow Rate Low PBP Flow Rate Low Replacement Flow Rate Low Replacement 2 Flow Rate

Monitor output: alarms from Baxter PrisMax Hemodialysis		
Mindray Patient Monitor		Baxter PrisMax Hemodialysis Alarm
Priority	Label	Label
Low	Flow Problem	<p>If the monitor shows the alarm [Flow Problem], the external device may have the alarms:</p> <ul style="list-style-type: none"> Low Dialysate Flow Rate Low Front Effluent Fill Flow Rate Low Side/Rear Effluent Drain Flow Rate Low Side/Rear Effluent Fill Flow Rate
Low	Low Technical Alarm	<p>If the monitor shows the alarm [Low Technical Alarm], the external device may have the alarms:</p> <ul style="list-style-type: none"> Battery Low Loss of AC Power Fluid in Drip Tray Membrane Pressure Rising override Effluent Bag Full Auto Effluent (AE) Bags Full Bag Empty Rep Bag Empty Scale Open Scale Not Opened Scale Calibration Temperature - Small Delta Wrong Effluent Bag Size Blood Leak Line Missing - Switch No Line in Discharger Battery Temperature Scale Not Opened

Monitor output: alarms from Baxter PrisMax Hemodialysis		
Mindray Patient Monitor		Baxter PrisMax Hemodialysis Alarm
Priority	Label	Label
		Scale Unstable Flow Problem Scale Not Opened Syringe Empty High BLD Output Voltage Syringe Force Low Preventive Maintenance Past Due Clamped Lines Test Failed PBP Bag Overweight Rep Bag Overweight Dia Bag Overweight Rep2 Bag Overweight Prescription Changes Timeout Battery Not Present Connectivity Test Communications Lost TherMax Malfunction TherMax Plate Temp Excessive Ambient Temp Sensor Failure TPE Treatment Completed Calcium Infusion Stopped

Monitor output: alarms from Baxter PrisMax Hemodialysis		
Mindray Patient Monitor		Baxter PrisMax Hemodialysis Alarm
Priority	Label	Label
Low	Low Technical Alarm	<p>If the monitor shows the alarm [Low Technical Alarm], the external device may have the alarms:</p> <ul style="list-style-type: none"> Calcium Syringe Empty Calcium Line Clamped Calcium Syringe Not Detected Bulk1 Bag Empty Bulk2 Bag Empty Inf Scale Open Bulk1 Scale Open Bulk2 Scale Open Ca++ Reminder Air removal Air insertion Calcium Syringe Line Not Connected Effluent Pump Failure Check Calcium Line Calcium Syringe Force Low Check Calcium Syringe Line PBP Line Attached to Rep2 Verify Sweep Gas High Buffer Load ECCOR Checkpoint Reminder Batter Temperature Problem Liquid Level Sensor Fail Return Line Disconnected in Prime Alarm Sound test Chamber Level High Chamber Level Low Blood Flow Rate Too Low

Monitor output: alarms from Baxter PrisMax Hemodialysis		
Mindray Patient Monitor		Baxter PrisMax Hemodialysis Alarm
Priority	Label	Label
Prompt	Information Alarm	<p>If the monitor shows the alarm [Information Alarm], the external device may have the alarms:</p> <ul style="list-style-type: none"> Wrong Set Detected PBP Attached to Rep Bag Prime Solution Empty Pump Occlusivity Test Fail TherMax Disposable Installed Replacement Line Clamped Dialysate Line Clamped PBP Line Clamped PBP Line Not Connected Dia Line Attached to Rep Bag

Monitor output: alarms from Baxter PrisMax Hemodialysis		
Mindray Patient Monitor		Baxter PrisMax Hemodialysis Alarm
Priority	Label	Label
Prompt	Information Alarm	<p>If the monitor shows the alarm [Information Alarm], the external device may have the alarms:</p> <ul style="list-style-type: none"> Dia Line Not Connected Set did not load correctly Pause Time Exceeded Crossed AE Lines Battery Not Charging Blood Leak Self-Test Failure Access Extremely Negative Side Effluent Bag Incorrect Front Effluent Bag Incorrect Prime Solution Empty PBP Line Attached to Dia Dia Line Attached to PBP Rep Line Attached to Dia Blood Leak Detector (BLD) Normalization Failed Scale Weight Problem Access pressure not zero Filter pressure not zero Effluent pressure not zero Return pressure not zero Dialysate Scale Weight Error Schedule Preventive Maintenance Check Syringe Line Bag Not Filling Replacement Pre/Post Pinch Valve - Prime Dialysate Pinch Valve - Prime Effluent Fill Pinch Valve - Prime Effluent Drain Pinch Valve - Prime Rep Line Attached to PBP Bag Rep Line Not Detected Rep Scale Weight Error PBP Scale Weight Error

Monitor output: alarms from Baxter PrisMax Hemodialysis		
Mindray Patient Monitor		Baxter PrisMax Hemodialysis Alarm
Priority	Label	Label
Prompt	Information Alarm	<p>If the monitor shows the alarm [Information Alarm], the external device may have the alarms:</p> <ul style="list-style-type: none"> No Line in Blood Leak Detector (BLD) Patient Lines Test In Progress Fluid Detected TPE Prime Solution Empty Syringe Arm Obstructed Effluent Bag Full Return Line in Return Clamp Bag Not Filling Defaults not Set Line in Component Rep Line Clamped Rep2 Line Attached to PBP Rep2 Attached to Rep Bag Rep2 Line Not Connected Rep Line Attached to Rep2 Rep2 Scale Weight Error Wrong Set Detected Return Barrier May Be Wet Bag on wrong scale Line Misconnected during Auto Effluent (AE) reuse Flow Problem Effluent Bag Incorrect Return Low Operating Point Effluent Bag Full TherMax Open Positive Return Pressure Failure Thermax Bag Not Detected TherMax Outlet Temperature Too High Blood Flow Rate Too Low Power Switch Off TherMax Outer Tubing Collapsed

Monitor output: alarms from Baxter PrisMax Hemodialysis		
Mindray Patient Monitor		Baxter PrisMax Hemodialysis Alarm
Priority	Label	Label
Prompt	Information Alarm	<p>If the monitor shows the alarm [Information Alarm], the external device may have the alarms:</p> <ul style="list-style-type: none"> TherMax Outlet Temp Too Low TherMax Blood Return Temperature Unattainable Patient High Voltage TherMax Bag Not Inflated TherMax Fluid Present TherMax Not level in Setup TMPa Pressure Rising Air Detected in Prime Air Detected in Flush LLS Foam Detected LLS Self-Test Failed Dialysate Pump Set Load Fail Replacement Pump Set Load Fail Pre-Blood Pump Set Load Fail Blood Pump Set Load Fail AEE Pump Set Load Fail Effluent Pump Set Load Fail Turn Off Sweep Gas Turn Off External Pump Turn On External Pump Interrupted Immediate Bolus

7.2 Dräger babyleo TN500 Incubater (For BeneVision N Series Monitors only)

7.2.1 Output Signals - Parameters

Monitor output: parameters from Dräger babyleo TN500 incubater			
Labels	Units	Description	Trend, record, print
Monitoring Parameters			
T Air	°C	Air temperature	Yes
Humidity	%	Relative humidity	Yes
O2	%	Oxygen concentration	Yes
Heater rad	%	Radiant warmer power	Yes
BW	Kg	Body weight	Yes
T Peri	°C	Peripheral skin temperature	Yes
T Centr	°C		Yes
T Matt	°C	Mattress temperature	Yes
ΔT Skin	°C	Central skin temperature	Yes
Light	lux	Light level	No
Noise	db(A)	Noise level	No
Heater conv	%	Convective heater power	Yes
Setting Parameters			
T Air	°C	Air temperature	No
T Skin	°C	Skin temperature	No
Humidity	%	Relative humidity	No
O2	%	Oxygen concentration	No
Heater rad	%	Radiant warmer power	No
T Matt	°C	Mattress temperature	No

7.2.2 Output Signals - Alarms

Monitor output: alarms from Dräger babyleo TN500 incubater		
Mindray Patient Monitor		Dräger babyleo TN500 incubater Alarm
Physiological alarms		
Priority	Label	Label
Medium	T Air High	AIR TEMP HI
Medium	T Air Low	AIR TEMP LOW
Medium	O2 Low	OXYGEN LOW
Medium	O2 High	OXYGEN HIGH
Medium	Δ T Skin High	DTEMP HIGH
Medium	Δ T Skin Low	DTEMP LOW
Medium	T Centr Low	CTEMP LOW
Medium	T Centr High	CTEMP HIGH
Medium	T Peri Low	PTEMP LOW
Medium	T Peri High	PTEMP HIGH
Medium	T Matt High	MAT TEMP HI
Low	Humidity Low	HUMIDITY LOW
Physiological alarms		
High	Air Htr Inop	AIR HTR INOP
High	System Fault	SYSTEM FAULT
Medium	O2 Sens Err	O2 SENS ERR
Medium	Mat Htr Inop	MAT HTR INOP
Medium	Sens Mod Err	SENS MOD ERR
Medium	Weaning Fail	WEANING FAIL
Medium	Int.Tmp.High	INT.TMP.HIGH
Medium	Fan Err	FAN ERR
Medium	Hum Inop	HUM INOP
Medium	Ctemp Err	CTEMP ERR
Medium	Ptemp Err	PTEMP ERR
Medium	Amb Temp Err	AMB TEMP ERR

Monitor output: alarms from Dräger babyleo TN500 incubater		
Mindray Patient Monitor	Dräger babyleo TN500 incubater Alarm	
Physiological alarms		
Priority	Label	Label
Medium	O2 Mod Inop	O2 MOD INOP
Low	Speaker Fail	SPEAKER FAIL
Low	Water Low	WATER LOW
Low	Check Hood	CHECK HOOD
Low	Check Wean	CHECK WEAN
Low	Weaning Done	WEANING DONE
Low	No Oxygen	NO OXYGEN

7.3 MAQUET Cardiosave hybrid IABP (For BeneVision N series Monitors)

7.3.1 Output Signals - Parameters

Monitor output: parameters from MAQUET Cardiosave hybrid IABP			
Labels	Unit	Description	Trend, record, print
Art-S	mmHg	assistedSystolicPressure	Yes
Art-D	mmHg	assistedDiastolicPressure	Yes
Art-M	mmHg	meanPressure	Yes
Aug.	mmHg	augmentedPressure	Yes
HR	bpm	heartRate	Yes

7.3.2 Output Signals - Alarms

Monitor output: alarms from MAQUET Cardiosave hybrid IABP		
Mindray Patient Monitor		MAQUET Cardiosave hybrid IABP Alarm
Priority	Label	Label
Physiological alarms		
Medium	Augmentation Below Limit Set	Augmentation Below Limit Set
Technical alarms		
High	System Failure	System Failure
High	Gas Gain In IAB Circuit	Gas Gain In IAB Circuit
High	Autofill Failure - No helium	If the monitor shows the alarm [Autofill Failure - No helium], the external device may have the alarms: Autofill Failure - No Helium Console Autofill Failure - No Helium Transport
High	Autofill Failure	If the monitor shows the alarm [Autofill Failure], the external device may have the alarms: Autofill Failure - Blood Suspected Autofill Failure
High	IAB Disconnected	IAB Disconnected
High	High driver pressure	High driver pressure
High	Check IAB Catheter	If the monitor shows the alarm [Check IAB Catheter], the external device may have the alarms: IAB Catheter Restriction Fiber-Optic IAB Signal Failure
High	Leak in IAB circuit	Leak in IAB circuit
High	Low Vacuum	Low Vacuum
High	Trigger Interference	Trigger Interference
High	Check Pacer Timing	Check Pacer Timing
High	NO Trigger	If the monitor shows the alarm [NO Trigger], the external device may have the alarms: No Trigger Auto Mode No Trigger on Switch Auto Mode

Monitor output: alarms from MAQUET Cardiosave hybrid IABP		
Mindray Patient Monitor		MAQUET Cardiosave hybrid IABP Alarm
Priority	Label	Label
High	Poor Signals Persist	Poor Signals Persist
High	NO Pressure Trigger	If the monitor shows the alarm [NO Pressure Trigger], the external device may have the alarms : No Pressure Trigger No Pressure Trigger on Switch
High	High Technical Alarm	If the monitor shows the alarm [High Technical Alarm], the external device may have the alarms : Power-Up Test Fails Internal Communication Failure System Over temperature
Medium	ECG Detected	ECG Detected
Medium	Poor Signal Quality	Poor Signal Quality
Medium	No Pressure Source Available	No Pressure Source Available
Medium	Low battery	Low battery
Medium	Unable To Update Timing	Unable To Update Timing
Medium	Medium Technical Alarm	If the monitor shows the alarm [Medium Technical Alarm], the external device may have the alarms : Over Temperature Condition Detected Transport Power Supply Over Temperature

Monitor output: alarms from MAQUET Cardiosave hybrid IABP		
Mindray Patient Monitor		MAQUET Cardiosave hybrid IABP Alarm
Priority	Label	Label
Medium	ECG Lead Off	<p>If the monitor shows the alarm [ECG Lead Off], the external device may have the alarms:</p> <ul style="list-style-type: none"> Left arm electrode faulted Left leg electrode faulted Right and left arm electrode faulted Right arm and left leg electrode faulted Left arm and left leg electrode faulted Unable to pin point the faulted electrodes Chest lead faulted Right leg electrode faulted Chest lead and right leg electrode faulted ECG cable disconnected

7.4 MAQUET CS300/CS100 IABP (For BeneVision N series Monitors)

7.4.1 Output Signals - Parameters

Monitor output: parameters from MAQUET CS300/CS100 IABP			
Labels	Units	Description	Trend, record, print
HR	bpm	Heart Rate	Yes
Art-S	mmHg, kPa	Systolic Blood Pressure	Yes
Art-D	mmHg, kPa	Diastolic Blood Pressure	Yes
Art-M	mmHg, kPa	Mean Blood Pressure	Yes
Aug.	mmHg, kPa	Augmented Blood	Yes

7.4.2 Output Signals - Alarms

Monitor output: alarms from MAQUET IABP		
Mindray Patient Monitor		MAQUET IABP Alarm
Priority	Label	Label
Physiological alarms		
Medium	Augmentation Below limit set	Augmentation below limit set
Technical alarms		
High	NO Trigger	NO Trigger
High	NO Pressure Trigger	NO Pressure Trigger
High	Check Pacer Timing	Check Pacer Timing
High	Trigger Interference	Trigger Interference
High	Rapid gas loss	Rapid gas loss
High	Leak in IAB circuit	Leak in IAB circuit
High	IAB Disconnected	IAB Disconnected
High	Blood detected	Blood detected
High	Check IAB Catheter	Check IAB catheter
High	High driver pressure	High drive pressure
High	Low Vacuum	Low Vacuum
High	System Failure	SYSTEM FAILURE
High	Electrical Test Failure	ELECTRICAL TEST FAILURE
High	Autofill Failure	Autofill Failure
High	Autofill Failure - No helium	Autofill Failure - NoHelium
High	Safety disk test failure	Safety Disk test failure
High	No patient status available	No Patient Status Available
High	Autofill Required	Autofill Required
High	Poor Signal Persist	Poor Signals Persist
Medium	ECG Detected	ECG Detected
Medium	Irregular Trigger	Irregular Trigger
Medium	Low helium	Low Helium

Monitor output: alarms from MAQUET IABP		
Mindray Patient Monitor		MAQUET IABP Alarm
Priority	Label	Label
Medium	Low Battery	Low Battery
Medium	Low Battery(EXT)	Low Battery (EXT)
Medium	Maintenance required	MAINTENANCE REQUIRED
Medium	Prolonged Time in Standby	Prolonged Time in Standby
Medium	Irregular pressure trigger	Irregular Pressure Trigger
Medium	No pressure source available	No Pressure Source Available
Medium	Poor Signal Quality	Poor Signal Quality
Medium	Unable to update timing	Unable To Update Timing
Medium	Unable to Calibrate Sensor IAB	Unable to Calibrate Sensor IAB
Medium	Sensor IAB Calibration Expired	Sensor IAB Calibration Expired
Medium	Sensor IAB Failure	Sensor IAB Failure
Medium	Sensor IAB Module Failure	Sensor IAB Module Failure

7.5 MAQUET PulsioFlex Cardiac Monitoring Device (For BeneVision N series Monitors)

7.5.1 Output Signals - Parameters

Monitor output: parameters from MAQUET PulsioFlex Cardiac Monitoring Device			
Labels	Units	Description	Trend, record, print
CCI	L/min/m2	Continuous Cardiac Index	Yes
SVV	%	Stroke volume variation	Yes
SVRI	DS.m2/cm5	Systemic Vascular Resistance Index	Yes
GEF	%	Global Ejection Fraction	Yes

Monitor output: parameters from MAQUET PulsioFlex Cardiac Monitoring Device			
Labels	Units	Description	Trend, record, print
GEDI	ml/min	Global End-Diastolic Volume Index	Yes
ELWI	ml/kg	Extra Vascular Lung Water Index	Yes
PDR	%/min	Plasma Disappearance Rate (of ICG)	No
dpMx	mmHg/s	Index of left ventricular contractility	Yes
PVPI	\	Pulmonary Vascular Permeability Index	Yes
CFI	L/min	Cardiac Function Index	Yes
CPI	W/m ²	Cardiac Power Index	Yes
SVI	ml/m ²	Stroke Volume Index	Yes
CCO	L/min	Continuous Cardiac Output	Yes
SVR	DS/cm ⁵	Systemic Vascular Resistance	Yes
PPV	%	Pulse pressure variation	Yes
C.I.	L/min/m ²	Discontinuous Cardiac Index from thermodilution	Yes
C.O.	L/min	Discontinuous Cardiac Output from thermodilution	Yes
CPO	W	Cardiac Power	Yes
GEDV	ml	Global End-Diastolic Volume	Yes
EVLW	ml	Extra Vascular Lung Water	Yes
R15	%	Retention Rate (of ICG)	No
SV	ml	Stroke Volume	Yes
TB	°C, °F	Blood temperature	Yes
pArt-S	mmHg, kPa	Systolic arterial pressure	Yes
pArt-D	mmHg, kPa	Diastolic arterial pressure	Yes
pArt-M	mmHg, kPa	Mean arterial pressure	Yes
ScvO ₂	%	Central Venous Oxygen Saturation	Yes
DO ₂	ml/min	Oxygen Delivery	No

Monitor output: parameters from MAQUET PulsioFlex Cardiac Monitoring Device			
Labels	Units	Description	Trend, record, print
DO2I	ml/min/m2	Oxygen Delivery Index	No
VO2	ml/min	Oxygen Consumption	No
VO2I	ml/min/m2	Oxygen Consumption Index	No
O2ER	%	Oxygen Extraction Ratio	No

7.5.2 Output Signals - Alarms

Monitor output: alarms from MAQUET PulsioFlex Cardiac Monitoring Device		
Mindray Patient Monitor		PulsioFlex Alarm
Priority	Label	Label
Physiological alarms		
High	pArt-S Low	ApSys Low
High	pArt-S High	ApSys High
High	pArt-M Low	ApMap Low
High	pArt-M High	ApMap High
High	CCO Low	CO Low
High	CCO High	CO High
High	CCI Low	CI Low
High	CCI High	CI High
High	ScvO2 High	ScvO2 High
High	ScvO2 Low	ScvO2 Low
Technical alarms		
High	Map Drop-check catheter	Map drop-Check catheter
High	AP/HR Not Available-please check	HR/AP not available-Please check

7.6 Medasense PMD200 Pain Response Monitoring Device (For BeneVision N series Monitors)

7.6.1 Output Signals - Parameters

Monitor output: parameters from Medasense PMD200 Pain response monitoring device			
Labels	Units	Description	Trend, record, print
NOL	/	NOL	Yes
NOLavg.	/	NOL average	Yes

7.6.2 Output Signals - Technical Alarms

Monitor output: alarms from Medasense PMD200 Pain response monitoring device		
Mindray Patient Monitor		Medasense PMD200 Alarm
Priority	Label	Label
High	Check Probe	Check Probe alert
	Low Battery	Battery status
Medium	Movement detected	Movement detected alert
Low	Trendelenburg detected	Trendelenburg detected
Prompt	PPG Poor Signal Quality	PPG Signal quality alert
Prompt	GSR Poor Signal Quality	GSR Signal quality alert
Prompt	Sensor Calibrating	Calibrating
Prompt	Connect Probe	Probe alert

7.6.3 Output Signals - Waveforms (For BeneVision N series Monitors)

Label	Units
GSR	/
PPG	/

7.7 Narcotrend Compact M EEG Monitoring Devices (For BeneVision N series Monitors)

7.7.1 Output Signals - Parameters

Monitor output: parameters from Narcotrend Compact M EEG Monitoring Device			
Labels	Units	Description	Trend, record, print
CFI1	\	NI	Yes
EMG1	%	EMG	Yes
Delta1	%	DeltaRel1	No
Delta2	%	DeltaRel2	No
Theta1	%	ThetaRel1	No
Theta2	%	ThetaRel2	No
Alpha1	%	AlphaRel1	No
Alpha2	%	AlphaRel2	No
Beta1	%	BetaRel1	No
Beta2	%	BetaRel2	No
TP1	μ V2	Power1	Yes
TP2	μ V2	Power2	Yes
MF1	Hz	Median1	No
MF2	Hz	Median2	No
SEF1	Hz	EdgeFreq1	Yes
SEF2	Hz	EdgeFreq2	Yes
BSR1	%	BSRShort1	Yes
STI1	%	STI1	Yes
STI2	%	STI2	Yes
BSR2	%	BSRShort2	Yes
Imp1a	k Ω	Imp1a	No
Imp1b	k Ω	Imp1b	No
ImpRef	k Ω	ImpRef	No
Imp2a	k Ω	Imp2a	No
Imp2b	k Ω	Imp2b	No

7.7.2 Output Signals - Technical Alarms

Monitor output: alarms from Narcotrend Compact M EEG Monitoring Device		
Mindray Patient Monitor		Narcotrend Compact M Alarm
Priority	Label	Label
Prompt	CH1 Impedance	Impedance
Prompt	CH1 Offset	Offset
Prompt	CH1 EMG	EMG
Prompt	CH1 50 Hz / 60 Hz	50 Hz / 60 Hz
Prompt	CH1 Interferences	Interferences
Prompt	CH1 Sharp Transients	Sharp Transients
Prompt	CH1 Artifact	Artifact
Prompt	CH1 Start	Start
Prompt	CH1 Inhomogeneous	Inhomogeneous
Prompt	CH1 Undifferentiated EEG	Undifferentiated EEG
Prompt	CH2 Impedance	Impedance
Prompt	CH2 Offset	Offset
Prompt	CH2 EMG	EMG
Prompt	CH2 50 Hz / 60 Hz	50 Hz / 60 Hz
Prompt	CH2 Interferences	Interferences
Prompt	CH2 Sharp Transients	Sharp Transients
Prompt	CH2 Artifact	Artifact
Prompt	CH2 Start	Start
Prompt	CH2 Inhomogeneous	Inhomogeneous
Prompt	CH2 Undifferentiated EEG	Undifferentiated EEG
Prompt	No patient lead is connected	No patient lead is connected
Prompt	1a electrode bad (impedance)	1a electrode bad
Prompt	1b electrode bad (impedance)	1b electrode bad
Prompt	Ref electrode bad (impedance)	Ref electrode bad

Monitor output: alarms from Narcotrend Compact M EEG Monitoring Device		
Mindray Patient Monitor		Narcotrend Compact M Alarm
Priority	Label	Label
Prompt	2a electrode bad (impedance)	2a electrode bad
Prompt	2b electrode bad (impedance)	2b electrode bad
Prompt	Electrode check (the raw EEG may not valid)	Electrode Check

7.7.3 Output Signals - Waveforms

Label	Units
EEG1	μV
EEG2	μV

7.8 NONIN X-100M Oximetry Monitor (For BeneVision N series Monitors)

NOTE

- Only the Benevision N Series monitor with system software V02.24.00 or higher supports integration with the NONIN X-100M Oximetry Monitor.

7.8.1 Output Signals - Parameters

Monitor output: parameters from NONIN X-100M Oximetry Monitor			
Labels	Units	Description	Trend, record, print
rSO2-1	%	Regional Oxygenation	Yes
Hbl-1	g/dL, mmol/L,g/L	Hemoglobin Index	Yes
AUC-1	/	Area Under the Curve	Yes
Baseline-1	%	Baseline	No
rSO2-2	%	Regional Oxygenation	Yes

Monitor output: parameters from NONIN X-100M Oximetry Monitor			
Labels	Units	Description	Trend, record, print
Hbl-2	g/dL, mmol/L,g/L	Hemoglobin Index	Yes
AUC-2		Area Under the Curve	Yes
Baseline-2	%	Baseline	No
rSO2-1'	%	Regional Oxygenation	Yes
Hbl-1'	g/dL, mmol/L,g/L	Hemoglobin Index	Yes
AUC-1'	/	Area Under the Curve	Yes
Baseline-1'	%	Baseline	No
rSO2-2'	%	Regional Oxygenation	Yes
Hbl-2'	g/dL, mmol/L,g/L	Hemoglobin Index	Yes
AUC-2'	/	Area Under the Curve	Yes
Baseline-2'	%	Baseline	No
SpO2	%	Oxygen saturation	Yes
PR	bpm	Pulse Rate	Yes
SpO2-2	%	Oxygen saturation	Yes
PR-2	bpm	Pulse Rate	Yes
SpO2-3	%	Oxygen saturation	Yes
PR-3	bpm	Pulse Rate	Yes
SpO2-4	%	Oxygen saturation	Yes
PR-4	bpm	Pulse Rate	Yes
SpO2-5	%	Oxygen saturation	Yes
PR-5	bpm	Pulse Rate	Yes
SpO2-6	%	Oxygen saturation	Yes
PR-6	bpm	Pulse Rate	Yes

7.8.2 Output Signals - Alarms

Monitor output: alarms from NONIN X-100M Oximetry Monitor		
Mindray Patient Monitor		NONIN X-100M Alarm
Priority	Label	Label
Physiological alarms		
High	rSO2-1 High	rSO2 High
High	rSO2-1 Low	rSO2 Low
High	rSO2-2 High	rSO2 High
High	rSO2-2 Low	rSO2 Low
High	rSO2-1' High	rSO2 High
High	rSO2-1' Low	rSO2 Low
High	rSO2-2' High	rSO2 High
High	rSO2-2' Low	rSO2 Low
High	SpO2 High	SpO2 High
High	SpO2 Low	SpO2 Low
High	SpO2-2 High	SpO2 High
High	SpO2-2 Low	SpO2 Low
High	SpO2-3 High	SpO2 High
High	SpO2-3 Low	SpO2 Low
High	SpO2-4 High	SpO2 High
High	SpO2-4 Low	SpO2 Low
High	SpO2-5 High	SpO2 High
High	SpO2-5 Low	SpO2 Low
High	SpO2-6 High	SpO2 High
High	SpO2-6 Low	SpO2 Low
High	PR High	PR High
High	PR Low	PR Low
High	PR-2 High	PR High
High	PR-2 Low	PR Low
High	PR-3 High	PR High

Monitor output: alarms from NONIN X-100M Oximetry Monitor		
Mindray Patient Monitor		NONIN X-100M Alarm
Priority	Label	Label
High	PR-3 Low	PR Low
High	PR-4 High	PR High
High	PR-4 Low	PR Low
High	PR-5 High	PR High
High	PR-5 Low	PR Low
High	PR-6 High	PR High
High	PR-6 Low	PR Low
Technical alarms		
High	Sensor Error	Sensor Fault
High	Pod Comm. Lost	Pod Comm. Lost
Prompt	Poor Signal Quality	Signal Quality
Low	Low Perfusion	Low Perfusion
	RSO2 Reach Critical	RSO2 Marginal

7.9 Organon TOF-Watch SX NMT Monitoring Device

7.9.1 Output Signals - Parameters

Monitor output: parameters from Organon TOF-Watch SX NMT Monitoring Device			
Labels	Units	Description	Trend, record, print
TOF-Ratio	%	Train-of-four ratio	Yes
TOF-Count	/	Train-of-four count	Yes
PTC	/	post tetanic count	Yes
Single	/	Single twitch stimulation	Yes
Tskin	°C, °F	Skin temperature	No
T1	%	Size of twitch 1 in %/	No
T2	%	Size of twitch 2 in %/	No

Monitor output: parameters from Organon TOF-Watch SX NMT Monitoring Device			
Labels	Units	Description	Trend, record, print
T3	%	Size of twitch 3 in %	No
T4	%	Size of twitch 4 in %	No

7.9.2 Output Signals - Alarms

Monitor output: alarms from Organon TOF-Watch SX NMT Monitoring Device		
Mindray Patient Monitor		TOF-Watch SX Alarm
Priority	Label	Label
Physiological alarms		
Medium	TOF Alarm	TOF Alarm Enabled
Technical alarms		
High	TWSX Battery Depleted	Battery empty
Medium	TWSX Low Battery	Battery Low
Low	TWSX No Acceleration Sensor	AccelleCable Not Mounted
Low	TWSX No Temp Sensor	TempCable Not Mounted
Low	TWSX No Stimulation Cable	SurfaceCable Not Mounted
Low	TWSX Technical Alarm	SkinResist Too high Calibration Error BadAccSignal BadTempSignal StimMissing AccMissing BadElectrode Internal Error
Prompt	TWSX Not Cal	Cal not calib

7.10 NIRO Monitor NIRO-200NX (For BeneVision N Series Monitors)

7.10.1 Output Signals - Parameters

Monitor output: parameters from Carefusion Alaris Infusion Management System			
Labels	Units	Description	Trend, record, print
TOI_1	%	Tissue Oxygenation Index	Yes
nTHI_1	/	normalized Tissue Hemoglobin Index	Yes
O2Hb_1	/	oxygenated hemoglobin	Yes
HHb_1	/	deoxygenated hemoglobin	Yes
TOI_2	%	Tissue Oxygenation Index	Yes
nTHI_2	/	normalized Tissue Hemoglobin Index	Yes
O2Hb_2	/	oxygenated hemoglobin	Yes
HHb_2	/	deoxygenated hemoglobin	Yes
TOI_3	%	Tissue Oxygenation Index	Yes
nTHI_3	/	normalized Tissue Hemoglobin Index	Yes
O2Hb_3	/	oxygenated hemoglobin	Yes
HHb_3	/	deoxygenated hemoglobin	Yes
TOI_4	%	Tissue Oxygenation Index	Yes
nTHI_4	/	normalized Tissue Hemoglobin Index	Yes
O2Hb_4	/	oxygenated hemoglobin	Yes
HHb_4	/	deoxygenated hemoglobin	Yes

This page intentionally left blank.

8 BeneLink Function Test

8.1 Preparing the Tools

Prepare the tools for the function test according to the type of the external device you install. Please see the Instructions for Use of the corresponding external device for guidance. For the function test of ventilator and anesthesia machine, at least the following tools are needed:

- BeneVision patient monitor with BeneLink module properly installed
- Anesthesia machine or ventilator
- Gas source (tube or gas cylinder), including air or O₂ at least, and with N₂O or other anesthesia gases as options
- Tube that connects the or test lung
- Test lung and a matching Y-pipe, or other accessories

CAUTION

- **The Function tests should only be conducted by Mindray authorized personnel.**
 - **Function tests should not be performed while in use with a patient.**
-

8.2 Checking the Function

To check the function of the BeneLink module, follow this procedure:

1. Connect the BeneLink module to the ventilator or the anesthesia machine. See **2.7 Connecting External Devices** for more details.
2. Connect the gas supply and test lungs to the ventilator or anesthesia machine, turn on the device, and configure as follows:
 - ◆ Set the serial port of the external device by referring to **8.3 Setting the Serial Ports**.
 - ◆ Set the pressure control mode and check if the ventilator or anesthesia machine works normally.
3. Make sure the ID adapter is correctly configured, and the green indicator of corresponding port on the BeneLink module illuminates constantly.
4. Access the **Integrated Devices** screen on the patient monitor. Check that the device type (ventilator or anesthesia machine) and ventilation mode are correctly displayed.

5. Select parameters PEEP, Pmean, TVe, MV, I:E, and f(RR) respectively on the patient monitor and check if the parameter values displayed on the patient monitor are consistent with those displayed on the ventilator or anesthesia machine.
6. Re-configure the above parameters on the ventilator or the anesthesia machine and check if the parameter values displayed on the patient monitor change accordingly.
7. Trigger alarms **MV Low, Airway Pressure Too High, PAW High, Peak High** and **No Gas Supply** (no Air or O2) on the ventilator or the anesthesia machine. Check whether these alarm messages are correctly recorded in the alarm list of the patient monitor.
8. Switch the ventilator or anesthesia machine to volume control ventilation mode. Check if the ventilation mode displayed on the patient monitor changes accordingly, and if the parameter values of PEEP, Pmean, TVe, MV, I:E, and f(RR) are correctly displayed.

8.3 Setting the Serial Ports

8.3.1 Setting the Serial Ports of the Anesthesia Machines

Brand	Model	Protocol	Baud Rate	Data Bits	Stop Bits	Parity	Remark
Draeger	Apollo	Medibus	9600	8	1	Even	Push knob/Switch screen/power together → System Service Screen → Serial Port
Draeger	Atlan A3X0	Medibus.X	19200	8	1	Even	In the standby mode, select System → Interface → COM, Make the following Setting: <ul style="list-style-type: none"> • Baud Rate: 19200 • Parity: EVEN • Stop Bits: 1 • Data Bits: 8 • Protocol: MEDIBUS.X
Draeger	Fabius GS/Fabius GS Premium	Medibus	9600	7	1	Even	Push knob/Switch screen/power together → System Service Screen → Serial Port
Draeger	Fabius plus/Fabius Tiro/ Plus XL	Medibus	9600	7	1	Even	<ol style="list-style-type: none"> 1. In the standby mode, push knob/Switch screen/power together → System Service Screen → Serial Port 2. Select Serial Port → Parameters → Enter the Service Port Parameters Screen → Make the following Setting: <ul style="list-style-type: none"> •Baud Rate: 9600 •Parity: EVEN •Stop Bits: 1 •Data Bits: 7 •Protocol: MEDIBUS 3. The Setting take effect after shutdown and reboot.
Draeger	Perseus A500	Medibus	9600	8	1	Even	System Setup → System → interface

Brand	Model	Protocol	Baud Rate	Data Bits	Stop Bits	Parity	Remark
Draeger	Primus/Primus Infinity	Medibus	9600	8	1	Even	Push knob/Switch screen/power together → System Service Screen → Serial Port
Draeger	Zeus/ZeusE	Medibus	9600	8	1	Even	<ul style="list-style-type: none"> • Biomed Service → Basic Setup → Medibus Setup → Com1/ Com2 • Commands to Medibus device: ON • Medibus version: SW4.n • Port : ON
GE	Aespire 7900/7100	/	19200	7	1	Odd	No need to set
GE	AespireView	/	19200	7	1	Odd	No need to set
GE	Aestiva 7900/7100	/	19200	7	1	Odd	No need to set
GE	Aisys/Aisys CS2	/	19200	7	1	Odd	No need to set
GE	Avance/ Avance CS2	/	19200	7	1	Odd	No need to set
GE	Carestation 620/650	/	19200	7	1	Odd	No need to set
Hul	Leon	/	19200	8	1	None	Standby → switch screen → Login → Service Engineer (password:0002) → Configuration → Page 2 → Serial Protocol: On, Mode: request driven
Hul	Leon Plus	/	19200	8	1	None	Standby → switch screen → Login → Service Engineer (password:0002) → Configuration → Page 2 → Serial Protocol: On, Mode: request driven
MAQUET	FLOW-i/c/e	/	38400	8	1	Even	No need to set
Mindray	A9/A8/A7/A5/A4/A3	WATO	/	/	/	/	<ol style="list-style-type: none"> 1. Enter the Standby mode. 2. Select Setup to enter the System Setup menu (password is 1234). 3. Select Network → Serial → Protocol: MR-WATO.

Brand	Model	Protocol	Baud Rate	Data Bits	Stop Bits	Parity	Remark
Mindray	WATO EX-65/60/55/ 50/35/30/25/20/EX- 55 Pro/EX-65 Pro	WATO	/	/	/	/	1. Enter the Standby mode. 2. Select Setup to enter the System Setup menu (password is 1234). 3. Select Network → Serial → Protocol: MR-WATO.

8.3.2 Setting the Serial Ports of the Ventilator

Brand	Model	Protocol	Baud Rate	Data Bits	Stop Bits	Parity	Remark
ACUTRONIC	Fabian HFO	/	38400	8	1	None	1. Copy the licence install SW-Package on an empty USB-Stick 2. Connect the USB-Stick with fabian HFO/EVO and turn it on 3. homescreen → Licensing → "install license form USB" 4. homescreen → PDMS. Set as follows: •Version aculink: "4.x." •Interface: "Serial (with waves)" 5. Select "Cancel" from homescreen and restart the device.
AirLiquide	ALMS T75	/	38400	8	1	None	No need to set
Carefusion	Avea(VOXP)/ Vela	/	115200	8	1	None	/
Draeger	Babylog 8000/ 8000plus	/	9600	8	1	None	Cal. Config → config → com → Start bit: 1
Draeger	Evita 2	Medibus	19200	8	1	Even	• Channel A: No need to set • Channel B: Menu Mode → Other
Draeger	Evita 2 Dura	Medibus	19200	8	1	Even	Cal. Conf. → Device → Interface
Draeger	Evita 4	Medibus	19200	8	1	Even	Configuration → Ventilation → System Defaults → Interface
Draeger	Evita XL	Medibus	19200	8	1	Even	/

Brand	Model	Protocol	Baud Rate	Data Bits	Stop Bits	Parity	Remark
Draeger	Evita V300	Medibus Medibus.X	19200	8	1	Even	System setup → system → interface → COM
Draeger	Infinity V500/ Babylog VN500/Babylog VN800	Medibus Medibus.X	19200	/	1	Even	System setup → system → interface → COM → Start bit: 1
Draeger	Evita V600	Medibus Com	19200	8	1	Even	System setup → system → interface → COM → Start bit: 1
Draeger	Evita V800	Medibus MED.X Comp	19200	/	1	Even	System setup → system → interface → COM → Start bit: 1
Draeger	Savina 300	Medibus Medibus.X	19200	8	1	Even	System Setup → Interface
Draeger	Oxylog 3000 plus	Medibus.X	19200	8	1	Even	No need to set
GE	Carescape R860	/	19200	7	1	Odd	No need to set
GE	Engström Carestation	/	19200	7	1	Odd	No need to set
Hamilton	C1/C6	Block	38400	8	1	None	<ol style="list-style-type: none"> 1. Enter the Standby mode. 2. Select Tools → Configuration (Password: 7132) 3. In the Configuration menu, select More → select protocol (Hamilton Block). 4. Follow the prompts to restart.
Hamilton	C1/C1 NEO/C2/ C3/C6/C6S/T1	Polling	9600	7	2	Even	System → General → More → RS232 Protocol: GALILEO compatible. NOTE: an adapting cable (P/N: 161545) is required for the Hamilton C1/T1. This cable is provided by Hamilton.
Hamilton	G5	Block	38400	8	1	None	Enter the Configuration menu.

Brand	Model	Protocol	Baud Rate	Data Bits	Stop Bits	Parity	Remark
Hamilton	G5/S1	Polling	9600	7	2	Even	<ol style="list-style-type: none"> 1. Enter the Standby mode. 2. Press and hold hard keys "O2 ICON" and "Lung ICON", "Lock/Unlock ICON" and "On/Off ICON". 3. Select Configuration → Interface. 4. Set com1/2 to Hamilton C5/Polling.
Hamilton	Galileo	Polling	9600	7	2	Even	Enter the Configuration menu.
Hamilton	S1	Block	38400	8	1	None	<ol style="list-style-type: none"> 1. Enter the Standby mode. 2. Press and hold hard keys "O2 ICON" and "Lung ICON", "Lock/Unlock ICON" and "On/Off ICON". 3. Select Configuration → Interface. 4. Set com1/2 to Hamilton G5/Block
Hul	Leon i Plus	/	19200	8	1	None	<ol style="list-style-type: none"> 1. Select Standby → switch screen → Login → Service Engineer (password:0002) → "Connections. 2. Set as follows: Serial Protocol: On; Mode: request driven.
ImtMedical	Bellavista 1000	HL7	19200	8	1	None	Verwendung des Ports: HL7 HL7 Message Send Interval: 15s
MAQUET	SERVO-i/ SERVO-s	/	9600	8	1	Even	No need to set
MAQUET	SERVO-U/ SERVO-N	/	38400	8	1	Even	No need to set
MAQUET	SERVO-Air	/	38400	8	1	Even	No need to set
Mindray	NB300/NB350/ NB380	WATO	/	/	/	/	<ol style="list-style-type: none"> 1. Enter the Standby mode. 2. Select Setup to enter the System Setup menu (password is 1234). 3. Select Interface Setting → Serial → Protocol: MR-WATO.

Brand	Model	Protocol	Baud Rate	Data Bits	Stop Bits	Parity	Remark
Mindray	SV 300/350/ 600/650/800/ 850	WATO	115200/ 57600	/	/	/	<ol style="list-style-type: none"> 1. Enter the Standby mode. 2. Select Setup to enter the System Setup menu (password is 1234 or 1118). 3. Select Interface Setting → Serial → Protocol: MR-WATO. 4. If the ventilator could set the BaudRate, (1) when you set it to 115200, you must connect the Benelink with 2.17.0.* and above; (2) when you set it to 57600, you must connect the Benelink with 2.16.0.* and below. 5. If the BaudRate cannot be set for the Ventilator, do not set the BaudRate, and there is no requirement for the Benelink version.
Mindray	SV60/SV60S/ SV70/SV70S	WATO	115200/ 57600	/	/	/	<ol style="list-style-type: none"> 1. Enter the Standby mode. 2. Select Setup to enter the System Setup menu (password is 1234 or 1118). 3. Select Interface Setting ? Serial ? Protocol: MR-WATO. 4. If the ventilator could set the BaudRate, (1) when you set it to 115200, you must connect the Benelink with 2.17.0.* and above; (2) when you set it to 57600, you must connect the Benelink with 2.16.0.* and below. 5. If the BaudRate cannot be set for the Ventilator, do not set the BaudRate, and there is no requirement for the Benelink version.
Mindray	SynoVent E3/E5	WATO	/	/	/	/	No need to set
Newport	E360	Newport	38400	8	1	None	Setup & Calibration → Technical → Comm. Protocol: Newport
Philips	Respironics V60	SNDA VRPT	19200	8	1	None	Turn off machine → Hold confirm button and then push power button → Enter Diagnosis mode Note: An extra 25-pin to 9-pin adapter is required.

Brand	Model	Protocol	Baud Rate	Data Bits	Stop Bits	Parity	Remark
Puritan Bennett	PB840	SNDF SNDA	38400	8	/	None	Ventilator Setting → Other Screens → Communications Setup
Puritan Bennett	PB980	SNDF SNDA	38400	8	1	None	COM1: 840 DCI
ResMed	VSIII	/	9600	8	1	None	No need to set
Salvia	Elisa800/600/ 500/300	/	19200	7	1	Odd	No need to set
SLE	SLE6000	/	19200	8	1	None	No need to set

8.3.3 Setting the Serial Ports of the TcGas Monitoring Devices

Brand	Model	Protocol	Baud Rate	Data Bits	Stop Bits	Parity	Remark
RADIOMETER	TCM Tosca/ CombiM /TCM4/ TCM40	MonLink	9600	8	1	Even	Setup(password: 19100) → Tech.settings → Continuous data output: MonLink You need also the serial interface adapter with cable from RADIOMETER. (SN: 636-649)
RADIOMETER	TCM5	MonLink	/	/	/	/	Service (password: TCM5PW1) → Serial → protocol: Monlink for TCM4 Series
SenTec	SenTec Digital Monitor)	SenTecLink	115200	8	1	None	Interfaces → Serial Interface → Protocol: SenTecLink

8.3.4 Setting the Serial Ports of the Infusion Systems

Brand	Model	Protocol	Baud Rate	Data Bits	Stop Bits	Parity	Remark
B.Braun	Infusomat Space Perfusor Space	/	57600	8	1	None	<ol style="list-style-type: none"> 1. Use the Type F cable to connect the spaceCom connector of the SpaceStation (if cascading is needed, refer to the official documents on how to cascade several SpaceStation). 2. Connect an PC to the docking station through Ethernet. 3. Open the IE explorer and input 192.168.100.41 (Username: config, Password: config). 4. Configure the following parameters: <ul style="list-style-type: none"> •BCC configuration panel: BCC 3.3x •Interface: com1 •Baudrate: 57600 •Stop bits: 1 •Databits: 8 •Character Stuffing: On •Operation Mode: Request 5. Select Configuration ? Database Setting: Bed ID, set the Bed No.
Carefusion	Alaris GW/GH/PK/CC/ CGW/CGH	/	115200	8	1	None	<ol style="list-style-type: none"> 1. Connect the Carefusion Dock and the BeneLink module through the RJ45ToSerial Moduler Server. 2. Set the adapter as per the serial port parameters and network parameters.

Brand	Model	Protocol	Baud Rate	Data Bits	Stop Bits	Parity	Remark
Fresenius	Agilia Injectomat, Agilia Injectomat MC, Agilia Injectomat TIVA, Agilia Volumat, Agilia Volumat MC Agilia Link+, Agilia SP MC, Agilia VP MC	/	115200	8	1	None	<p>If Agilia SP MC and Agilia VP MC are connected with Link+, perform the following setup:</p> <ol style="list-style-type: none"> 1. Connect Agilia SP MC or Agilia VP MC with Link + using a network cable. 2. Set fixed IP (TCP/IPv4) as follows: <ul style="list-style-type: none"> •IP address: 192.168.0.20 •Subnet mask: 255.255.255.0 •Default gateway: 192.168.0.1 3. Input gateway IP (192.168.0.1) in the browser to access Fresenius Link+. 4. Select serial port switch: Configuration → Data Export → Serial export protocol for Agilia SP and VP → Enable. 5. Logout the Link + interface. 6. Disconnect the network cable. <p>For other models and configurations, setup is not required.</p> <p>Connection method:</p> <ul style="list-style-type: none"> • For Injectomat/Injectomat MC/Injectomat TIVA/Volumat/Volumat MC/SP MC/VP MC, use TYPE G adapting cable+ ID adapter. • For Link+ (4 Port Metal), use Type G adapting cable + ID adapter. • For Link+ (8 Port Metal+Plastic), use Fesenius Cable + Type C adapting cable + ID adapter.
Fresenius	Base Intensive/Base Primea	/	19200	7	1	Even	No need to set
Medima	MedimaNet Server	HL7	115200	8	1	None	Use the RJ45ToSerial Moduler Server to connect the BeneLink ID module and MedimaNet Server. Set the RJ45ToSerial Moduler Server basing on serial parameters and network parameters.
Mindray	BeneFusion DS5 (VP5/ SP5/SP5 TCI/SP5 DTCI)	/	115200	8	1	None	No need to set

Brand	Model	Protocol	Baud Rate	Data Bits	Stop Bits	Parity	Remark
Mindray	Benefusion nDS/nVP/nS	/	115200	8	1	None	No need to set

8.3.5 Setting the Serial Ports of Other External Devices

Brand	Model	Protocol	Baud Rate	Data Bits	Stop Bits	Parity	Remark
Baxter/Hemodialysis	Prismaflex/ PrisMax	/	9600	8	1	None	Select Maintain-Calibration → External Command port. Parameter settings are as follows: Master Timer: 5s RS232: Yes Required password are as follows: Prismaflex: 103116
Draeger/Incubator	babyleo TN500	MEDIBUS.X	19200	8	1	Even	System Setup (password: 0000) → System → Port → COM
MAQUET/cardiac monitoring device	PulsioFlex	/	19200	8	1	Even	Cable: ATEN USB to Serial Adapter UC-232A Main Menu → System → Service → LANCONF (Password) → Data Output → tick "Data output" → set protocol as "PulsioFlex V1.0"
MAQUET/ IABP	ICS300,CS100	/	2400	8	1	None	Adapting cable: mail to mail, directly connected. Maximum size of the connector is 15 mm × 33 mm.

Brand	Model	Protocol	Baud Rate	Data Bits	Stop Bits	Parity	Remark
MAQUET/ IABP	Cardiosave hybrid	/	115200	8	1	None	<ol style="list-style-type: none"> 1. Simultaneously press power button and the Low Level BP Output-Vent button to enter the Special Activation Main Menu. 2. Choose HIS/CIS Configuraion. 3. Set CardioSave Server IP Address. 4. Connect Cardiosave and RJ45ToSerial Moduler Server to the same router. 5. Set the IP address of the RJ45ToSerial Moduler Server at the same network with Cardiosave. Let the ,RJ45ToSerial Moduler Server work in the server mode. Set the server IP address as step 3. The server's port number is 33320. 6. Restart CardioSave. Select Pump Options → Network Connections → HIS/CIS.
Medasense/Pain response monitoring device	PMD200	/	19200	8	1	None	EXPORT → Tech Mode → Type the password: MedExConnect → Choose an external Patient monitor → Mindray
Narcotrend/EEG monitoring device	Compact M	/	115200	8	1	None	No Need to set
NONIN	X-100M	Nonin 5	57600	8	1	None	Set the Nonin serial port protocol to Nonin5 by selecting System → Data Output Modes → RS232 → Nonin5
Organon/NMT monitoring device	TOF-Watch SX	/	19200	8	1	None	No Need to set. The serial interface adapter with cable from Organon is required.
NIRO Monitor NIRO-200NX	NIRO-200NX	/	115200	8	1	None	Note: Set the Sample Time of 200NX to 10s or less. path: [Menu]->[Sample Time] No other Settings.

8.4 Troubleshooting Device Integration Failures

Failure Description	Possible Cause	Troubleshooting
The "Devices Integrated" window displays nothing after connection	The ID adapter is not compatible with the external device	1. Replace the ID adapter. 2. Upgrade the ID of the ID adapter in "Factory Maintenance" menu.
	The serial port adapter cable not compatible with the external device	Replace the serial port adapter cable.
	Wrong software version or wrong protocol version of the external device	Verify the protocol version and software version are supported by the ID adapter.
Generate the alarm: "BeneLink Comm Stop"	The BeneLink module application software is corrupted	Upgrade or update the software application of the BeneLink module with the network upgrading tool.
The patient monitor has no response when loading the ID adapter	The BeneLink module application software is corrupted	Upgrade or update the software application of the BeneLink module with the network upgrading tool.
	BeneLink module damaged	Replace the module.

8.5 Installation and Test Report

Basic Information			
Hospital		Department	
Serial number of ID adapter		Name of external device	
ID of the external device		Type of serial port adapting cable	
Software version and other information of the external device			
Checking the connection			Test Result (Yes/No)
Can the patient monitor and the external device be assembled together using designated accessories?			
Does the green indicator of corresponding port on the BeneLink module illuminate while the other indicators are not?			
Are there numerics or characters displayed on the Integrated Devices screen of the patient monitor?			
Are the device type and parameter values displayed correctly on the Integrated Devices screen of the patient monitor when the external device just enters working mode?			
Is the ventilation mode correctly displayed on the patient monitor? Does it change correctly when the ventilation mode on the external device is changed?			
Other information			

This page intentionally left blank.

9 Alarm ID of External Devices

If the storage, display, or audio settings of a specific external device alarm are different from its category or priority, you can set them individually by adding the Alarm ID to the alarm list. Refer to "Interfacing with External Devices" of the *N series Operator's Manual* (P/N: 046-009995-00) for the method.

This chapter lists the alarm IDs of external devices.

9.1 Alarm IDs of Anesthesia Machines

Alarm ID	Alarm message	Category	Alarm priority	Source
0xA5A1	Apnea	Phys	High	Anes
0xA5A2	Volume Apnea > 2 min	Phys	High	Anes
0xA5A3	Pressure Apnea	Phys	High	Anes
0xA5A4	Paw High	Phys	High	Anes
0xA5A5	Paw Low	Phys	High	Anes
0xA5A6	High Paw Sustained	Phys	High	Anes
0xA5A7	Pressure Limiting	Phys	Low	Anes
0xA5A8	Sub-Atmospheric Paw	Phys	Medium	Anes
0xA5A9	FiO2 High	Phys	Medium	Anes
0xA5AA	FiO2 Low	Phys	High	Anes
0xA5AB	TVe High	Phys	Medium	Anes
0xA5AC	TVe Low	Phys	Medium	Anes
0xA5AD	MV High	Phys	Medium	Anes
0xA5AE	MV Low	Phys	Medium	Anes
0xA5AF	RR High	Phys	Low	Anes
0xA5B0	RR Low	Phys	Low	Anes
0xA5B1	PEEP High	Phys	Medium	Anes
0xA5B2	PRESS EXP High	Phys	Medium	Anes
0xA5B3	PRESSURE LIM	Phys	Low	Anes

Alarm ID	Alarm message	Category	Alarm priority	Source
0xA5B4	CONT PRES	Phys	High	Anes
0xA5B5	Volume Apnea	Phys	Medium	Anes
0xA5B6	CO2 Apnea	Phys	High	Anes
0xA5B7	RR Low	Phys	Medium	Anes
0xA5B8	RR High	Phys	Medium	Anes
0xA5B9	EtCO2 High	Phys	Medium	Anes
0xA5BA	EtCO2 Low	Phys	Medium	Anes
0xA5BB	FiCO2 High	Phys	Medium	Anes
0xA5BC	FiCO2 Low	Phys	Medium	Anes
0xA5BD	EtN2O High	Phys	Medium	Anes
0xA5BE	EtN2O Low	Phys	Medium	Anes
0xA5BF	FiN2O High	Phys	Medium	Anes
0xA5C0	FiN2O Low	Phys	Medium	Anes
0xA5C1	EtHal High	Phys	Medium	Anes
0xA5C2	EtHal Low	Phys	Medium	Anes
0xA5C3	FiHal High	Phys	Medium	Anes
0xA5C4	FiHal Low	Phys	Medium	Anes
0xA5C5	EtEnf High	Phys	Medium	Anes
0xA5C6	EtEnf Low	Phys	Medium	Anes
0xA5C7	FiEnf High	Phys	Medium	Anes
0xA5C8	FiEnf Low	Phys	Medium	Anes
0xA5C9	EtIso High	Phys	Medium	Anes
0xA5CA	EtIso Low	Phys	Medium	Anes
0xA5CB	FiIso High	Phys	Medium	Anes
0xA5CC	FiIso Low	Phys	Medium	Anes
0xA5CD	EtSev High	Phys	Medium	Anes
0xA5CE	EtSev Low	Phys	Medium	Anes
0xA5CF	FiSev High	Phys	Medium	Anes
0xA5D0	FiSev Low	Phys	Medium	Anes
0xA5D1	EtDes High	Phys	Medium	Anes

Alarm ID	Alarm message	Category	Alarm priority	Source
0xA5D2	EtDes Low	Phys	Medium	Anes
0xA5D3	FiDes High	Phys	Medium	Anes
0xA5D4	FiDes Low	Phys	Medium	Anes
0xA5D5	MAC Low	Phys	Medium	Anes
0xA5D6	EtAA Low	Phys	Medium	Anes
0xA5D7	EtAA High	Phys	Medium	Anes
0xA5D8	FiAA Low	Phys	Medium	Anes
0xA5D9	FiAA High	Phys	Medium	Anes
0xA5DA	EtO2 High	Phys	High	Anes
0xA5DB	EtO2 Low	Phys	High	Anes
0xA5DC	FiO2 High	Phys	High	Anes
0xA5DD	FiO2 Low	Phys	High	Anes
0xA5DE	BIS High	Phys	Medium	Anes
0xA5DF	BIS Low	Phys	Medium	Anes
0xA5E0	No Pulse	Phys	High	Anes
0xA5E1	PR Low	Phys	High	Anes
0xA5E2	PR High	Phys	Medium	Anes
0xA5E3	SpO2 High	Phys	Medium	Anes
0xA5E4	SpO2 Low	Phys	High	Anes
0xA5E5	Patient Circuit Leak	Tech	Medium	Anes
0xA5E6	O2 Sensor Unconnected	Tech	Low	Anes
0xA5E7	Drive Gas Pressure Low	Tech	High	Anes
0xA5E8	O2 Supply Failure	Tech	High	Anes
0xA5E9	Battery in Use	Tech	Low	Anes
0xA5EA	APL VALVE?	Tech	High	Anes
0xA5EB	EXP-VALVE?	Tech	Medium	Anes
0xA5EC	FRESH GAS?	Tech	Medium	Anes
0xA5ED	No Fresh Gas	Tech	High	Anes
0xA5EE	Circuit Occluded	Tech	High	Anes

Alarm ID	Alarm message	Category	Alarm priority	Source
0xA5EF	VENT DISC	Tech	High	Anes
0xA5F0	NO AIR	Tech	Low	Anes
0xA5F1	NO O2 SUPPLY	Tech	Low	Anes
0xA5F2	High Technical Alarm	Tech	High	Anes
0xA5F3	Medium Technical Alarm	Tech	Medium	Anes
0xA5F4	Low Technical Alarm	Tech	Low	Anes
0xA5F5	Prompt	Tech	Prompt	Anes
0xA5F6	CO2 Module Abnormal	Tech	Medium	Anes
0xA5F7	AG Module Abnormal	Tech	Medium	Anes
0xA5F8	BIS Module Abnormal	Tech	Medium	Anes
0xA5F9	SpO2 Module Abnormal	Tech	Low	Anes
0xA5FA	PEEP Low	Phys	Medium	Anes
0xAA63	BIS L High	Phys	Medium	Anes
0xAA64	BIS L Low	Phys	Medium	Anes
0xAA65	BIS R High	Phys	Medium	Anes
0xAA66	BIS R Low	Phys	Medium	Anes
0xBA14	Paw High	Phys	High	Anes
0xBA15	MAC High	Phys	High	Anes

9.2 Alarm IDs of Ventilators

Alarm ID	Alarm message	Category	Alarm priority	Source
0xA65F	Paw High	Phys	High	Vent
0xA660	Paw Low	Phys	High	Vent
0xA661	MV High	Phys	Medium	Vent
0xA662	MV Low	Phys	Medium	Vent
0xA663	TVe High	Phys	Medium	Vent
0xA664	fspn High	Phys	Medium	Vent
0xA665	RR Low	Phys	Medium	Vent
0xA666	Apnea	Phys	High	Vent
0xA667	FiO2 High	Phys	High	Vent
0xA668	FiO2 Low	Phys	High	Vent
0xA669	Apnea Ventilation	Phys	High	Vent
0xA66A	Plimit Reached	Phys	Low	Vent
0xA66B	EtCO2 High	Phys	Medium	Vent
0xA66C	EtCO2 Low	Phys	Medium	Vent
0xA66D	FiCO2 High	Phys	Medium	Vent
0xA66E	VOL INCONST	Phys	Medium	Vent
0xA66F	RR High	Phys	Medium	Vent
0xA670	AW-TEMP HIGH	Phys	High	Vent
0xA671	PEEP High	Phys	High	Vent
0xA672	ASB > 4s	Phys	High	Vent
0xA673	ASB > 1.5s	Phys	Low	Vent
0xA674	PPS-TI > 1.5s	Phys	Low	Vent
0xA675	ASB > T _{insp}	Phys	Low	Vent
0xA676	No Pulse	Phys	High	Vent
0xA677	PR Low	Phys	High	Vent
0xA678	SpO2 Low	Phys	High	Vent
0xA679	PR High	Phys	High	Vent
0xA67A	SpO2 High	Phys	High	Vent

Alarm ID	Alarm message	Category	Alarm priority	Source
0xA67B	TVe Low	Phys	Medium	Vent
0xA67C	High Paw Sustained	Phys	High	Vent
0xA67D	Pressure Sustained	Phys	High	Vent
0xA67E	Sub-Atmospheric Paw	Phys	Medium	Vent
0xA67F	Pmax Reached	Phys	High	Vent
0xA680	Pinsp Not Achieved	Phys	High	Vent
0xA681	PEEP Not Achieved	Phys	High	Vent
0xA682	No Pressure PEEP/CPAP	Phys	High	Vent
0xA683	TV Not Achieved	Phys	High	Vent
0xA684	Volume Apnea	Phys	Medium	Vent
0xA685	Volume Apnea > 2 min	Phys	High	Vent
0xA686	High Circuit O2	Phys	High	Vent
0xA687	Low Circuit O2	Phys	High	Vent
0xA688	CO2 Apnea	Phys	High	Vent
0xA689	EtO2 High	Phys	Medium	Vent
0xA68A	EtO2 Low	Phys	Medium	Vent
0xA68B	Ppeak High	Phys	High	Vent
0xA68C	Ppeak Low	Phys	High	Vent
0xA68D	PEEPe High	Phys	Medium	Vent
0xA68E	PEEPe Low	Phys	Medium	Vent
0xA68F	PEEPi High	Phys	Medium	Vent
0xA690	Paux High	Phys	Medium	Vent
0xA691	Base Flow High	Phys	Low	Vent
0xA692	Loss of PEEP	Phys	High	Vent
0xA693	Low Baseline	Phys	High	Vent
0xA694	High Baseline	Phys	High	Vent
0xA695	Sustained Hbline	Phys	High	Vent
0xA696	Air Supply Pressure Low	Tech	High	Vent
0xA697	O2 Supply Pressure Low	Tech	High	Vent
0xA698	No Gas Supply Pressure	Tech	High	Vent

Alarm ID	Alarm message	Category	Alarm priority	Source
0xA699	Airway Obstructed?	Tech	High	Vent
0xA69A	Tube Disconnected?	Tech	High	Vent
0xA69B	Airway Leak?	Tech	Low	Vent
0xA69C	Battery in Use	Tech	Low	Vent
0xA69D	Check Flow Sensors	Tech	High	Vent
0xA69E	EXP-VALVE?	Tech	High	Vent
0xA69F	CLEAN CO2	Tech	High	Vent
0xA6A0	Drive Gas Pressure Low	Tech	High	Vent
0xA6A1	Patient Circuit Leak	Tech	Medium	Vent
0xA6A2	Neo Flow Sensor Error	Tech	High	Vent
0xA6A3	O2 and air supply	Tech	Medium	Vent
0xA6A4	O2 and heliox supply	Tech	Medium	Vent
0xA6A5	Sustained Airway Pressure	Tech	High	Vent
0xA6A6	Insp gas temperature high	Tech	High	Vent
0xA6A7	Tinsp Long	Tech	Low	Vent
0xA6A8	CO2 No Watertrap	Tech	Low	Vent
0xA6A9	No VO2, High FiN2O	Tech	High	Vent
0xA6AA	No O2 Pressure	Tech	High	Vent
0xA6AB	No Fresh Gas Flow	Tech	High	Vent
0xA6AC	No VO2, FiO2 > 85%	Tech	High	Vent
0xA6AD	MGAS Replace Water Trap	Tech	High	Vent
0xA6AE	12 Hour Test	Tech	Low	Vent
0xA6AF	Patient Connected?	Tech	High	Vent
0xA6B0	Negative Airway Pressure	Tech	High	Vent
0xA6B1	Circuit Leak	Tech	High	Vent
0xA6B2	Patient Connection Leak	Tech	High	Vent
0xA6B3	Patient Disconnected	Tech	High	Vent
0xA6B4	O2 cell disconnect	Tech	High	Vent
0xA6B5	Check tubing	Tech	Low	Vent
0xA6B6	Disconnection ventilator side	Tech	High	Vent

Alarm ID	Alarm message	Category	Alarm priority	Source
0xA6B7	O2 cell cal Needed	Tech	High	Vent
0xA6B8	Circuit Disconnect	Tech	High	Vent
0xA6B9	Power Failure	Tech	High	Vent
0xA6BA	Tinsp Short	Tech	High	Vent
0xA6BB	FiO2 Sensor Disconnected	Tech	Medium	Vent
0xA6BC	High Technical Alarm	Tech	High	Vent
0xA6BD	Medium Technical Alarm	Tech	Medium	Vent
0xA6BE	Low Technical Alarm	Tech	Low	Vent
0xA6BF	Prompt	Tech	Prompt	Vent
0xA6C0	PEEP Low	Phys	High	Vent
0xA6C1	FiO2 Alarm	Phys	High	Vent
0xA96E	High DCO2	Tech	Medium	Vent
0xA96F	Low DCO2	Tech	Medium	Vent
0xA970	SPO2 Desat	Phys	High	Vent
0xB8F1	Vent Wakeup	Phys	High	Vent
0xA90B	Apnea Ventilation Ended	Phys	Low	Vent
0xBA60	Cycle Fail	Phys	High	Vent
0xBA61	Continuing Positive Pressure	Phys	High	Vent
0xBA62	CPAP High	Phys	High	Vent
0xBA63	No Breath Detected	Phys	Medium	Vent
0xBA64	Sub Ambient Pressure	Phys	High	Vent
0xBA65	Pmean High	Phys	High	Vent
0xBA66	Pmean Low	Phys	High	Vent
0xBA67	Pressure change detected	Phys	High	Vent
0xBA68	Δ P High	Phys	High	Vent
0xBA69	Δ P Low	Phys	High	Vent
0xBA6A	FiCO2 Low	Phys	Medium	Vent
0xBA6B	High EtCO2 Spont	Phys	Medium	Vent
0xBA6C	PI Low	Phys	Medium	Vent
0xBA6D	PI High	Phys	Medium	Vent

Alarm ID	Alarm message	Category	Alarm priority	Source
0xBA56	PPV Pressure Too High	Tech	High	Vent
0xBA57	PPV TV Too High	Tech	High	Vent
0xBA58	VAPS: Target TV Not Achieved. Insufficient Pmax	Tech	High	Vent
0xBA59	VAPS: Target TV Exceeded. Pmin Too High	Tech	High	Vent
0xBA5A	Low Leak-CO2 Rebreathing Risk	Tech	High	Vent
0xBA5B	Proximal Pressure Line Disconnected	Tech	High	Vent
0xBA5C	High O2 Supply Pressure	Tech	High	Vent
0xBA95	泄露	Tech	High	Vent
0xBA96	CO2 模块错误	Tech	High	Vent
0xBA97	TV 未达到	Tech	Medium	Vent

9.3 Alarm IDs of tcGas Monitoring Devices

Alarm ID	Alarm message	Category	Alarm priority	Source
0xA6CB	PR Alarm	Phys	Medium	TcGas
0xA6CC	SpO2 Alarm	Phys	Medium	TcGas
0xA6CD	tcpCO2 Alarm	Phys	Medium	TcGas
0xA6CE	tcpO2 Alarm	Phys	Medium	TcGas
0xA6CF	tcGas Low Battery	Tech	Medium	TcGas
0xA6D0	tcGas Battery Depleted	Tech	High	TcGas
0xA6D1	TCM Temperature High	Tech	High	TcGas
0xA6D2	TCM Alert	Tech	Low	TcGas

9.4 Alarm IDs of NMT Monitoring Device

Alarm ID	Alarm message	Category	Alarm priority	Source
0xA6C2	TWSX Low Battery	Tech	Medium	NMT

Alarm ID	Alarm message	Category	Alarm priority	Source
0xA6C3	TWSX Battery Depleted	Tech	High	NMT
0xA6C4	TWSX No Acceleration Sensor	Tech	Low	NMT
0xA6C5	TWSX No Temp Sensor	Tech	Low	NMT
0xA6C6	TWSX No Stimulation Cable	Tech	Low	NMT
0xA6C7	TWSX Technical Alarm	Tech	Low	NMT
0xA6C8	TWSX Technical Alarm	Tech	Low	NMT
0xA6C9	TWSX Technical Alarm	Tech	Low	NMT
0xA6CA	TOF Alarm	Phys	Medium	NMT
0xA6D3	TWSX Technical Alarm	Tech	Low	NMT
0xA6D4	TWSX Technical Alarm	Tech	Low	NMT
0xA6D5	TWSX Not Cal	Tech	Prompt	NMT

9.5 Alarm IDs of Infusion Systems (for BeneVision N series Monitors)

Alarm ID	Alarm message	Category	Alarm priority	Source
0xA73F	Pre-Occlusion	Tech	Medium	Pump
0xA740	Pre-Occlusion	Tech	Medium	Pump
0xA741	Pre-Occlusion	Tech	Medium	Pump
0xA742	Pre-Occlusion	Tech	Medium	Pump
0xA743	Pre-Occlusion	Tech	Medium	Pump
0xA744	Pre-Occlusion	Tech	Medium	Pump
0xA745	Pre-Occlusion	Tech	Medium	Pump
0xA746	Pre-Occlusion	Tech	Medium	Pump

Alarm ID	Alarm message	Category	Alarm priority	Source
0xA747	Pre-Occlusion	Tech	Medium	Pump
0xA748	Pre-Occlusion	Tech	Medium	Pump
0xA749	Pre-Occlusion	Tech	Medium	Pump
0xA74A	Pre-Occlusion	Tech	Medium	Pump
0xA74B	Pre-Occlusion	Tech	Medium	Pump
0xA74C	Pre-Occlusion	Tech	Medium	Pump
0xA74D	Pre-Occlusion	Tech	Medium	Pump
0xA74E	Pre-Occlusion	Tech	Medium	Pump
0xA74F	Pre-Occlusion	Tech	Medium	Pump
0xA750	Pre-Occlusion	Tech	Medium	Pump
0xA751	Pre-Occlusion	Tech	Medium	Pump
0xA752	Pre-Occlusion	Tech	Medium	Pump
0xA753	Pre-Occlusion	Tech	Medium	Pump
0xA754	Pre-Occlusion	Tech	Medium	Pump
0xA755	Pre-Occlusion	Tech	Medium	Pump
0xA756	Pre-Occlusion	Tech	Medium	Pump
0xA757	Occlusion	Tech	High	Pump
0xA758	Occlusion	Tech	High	Pump
0xA759	Occlusion	Tech	High	Pump
0xA75A	Occlusion	Tech	High	Pump
0xA75B	Occlusion	Tech	High	Pump
0xA75C	Occlusion	Tech	High	Pump
0xA75D	Occlusion	Tech	High	Pump
0xA75E	Occlusion	Tech	High	Pump
0xA75F	Occlusion	Tech	High	Pump
0xA760	Occlusion	Tech	High	Pump
0xA761	Occlusion	Tech	High	Pump
0xA762	Occlusion	Tech	High	Pump
0xA763	Occlusion	Tech	High	Pump
0xA764	Occlusion	Tech	High	Pump

Alarm ID	Alarm message	Category	Alarm priority	Source
0xA765	Occlusion	Tech	High	Pump
0xA766	Occlusion	Tech	High	Pump
0xA767	Occlusion	Tech	High	Pump
0xA768	Occlusion	Tech	High	Pump
0xA769	Occlusion	Tech	High	Pump
0xA76A	Occlusion	Tech	High	Pump
0xA76B	Occlusion	Tech	High	Pump
0xA76C	Occlusion	Tech	High	Pump
0xA76D	Occlusion	Tech	High	Pump
0xA76E	Occlusion	Tech	High	Pump
0xA76F	Air bubble	Tech	High	Pump
0xA770	Air bubble	Tech	High	Pump
0xA771	Air bubble	Tech	High	Pump
0xA772	Air bubble	Tech	High	Pump
0xA773	Air bubble	Tech	High	Pump
0xA774	Air bubble	Tech	High	Pump
0xA775	Air bubble	Tech	High	Pump
0xA776	Air bubble	Tech	High	Pump
0xA777	Air bubble	Tech	High	Pump
0xA778	Air bubble	Tech	High	Pump
0xA779	Air bubble	Tech	High	Pump
0xA77A	Air bubble	Tech	High	Pump
0xA77B	Air bubble	Tech	High	Pump
0xA77C	Air bubble	Tech	High	Pump
0xA77D	Air bubble	Tech	High	Pump
0xA77E	Air bubble	Tech	High	Pump
0xA77F	Air bubble	Tech	High	Pump
0xA780	Air bubble	Tech	High	Pump
0xA781	Air bubble	Tech	High	Pump
0xA782	Air bubble	Tech	High	Pump

Alarm ID	Alarm message	Category	Alarm priority	Source
0xA783	Air bubble	Tech	High	Pump
0xA784	Air bubble	Tech	High	Pump
0xA785	Air bubble	Tech	High	Pump
0xA786	Air bubble	Tech	High	Pump
0xA787	Drop too less	Tech	High	Pump
0xA788	Drop too less	Tech	High	Pump
0xA789	Drop too less	Tech	High	Pump
0xA78A	Drop too less	Tech	High	Pump
0xA78B	Drop too less	Tech	High	Pump
0xA78C	Drop too less	Tech	High	Pump
0xA78D	Drop too less	Tech	High	Pump
0xA78E	Drop too less	Tech	High	Pump
0xA78F	Drop too less	Tech	High	Pump
0xA790	Drop too less	Tech	High	Pump
0xA791	Drop too less	Tech	High	Pump
0xA792	Drop too less	Tech	High	Pump
0xA793	Drop too less	Tech	High	Pump
0xA794	Drop too less	Tech	High	Pump
0xA795	Drop too less	Tech	High	Pump
0xA796	Drop too less	Tech	High	Pump
0xA797	Drop too less	Tech	High	Pump
0xA798	Drop too less	Tech	High	Pump
0xA799	Drop too less	Tech	High	Pump
0xA79A	Drop too less	Tech	High	Pump
0xA79B	Drop too less	Tech	High	Pump
0xA79C	Drop too less	Tech	High	Pump
0xA79D	Drop too less	Tech	High	Pump
0xA79E	Drop too less	Tech	High	Pump
0xA79F	Drop too many	Tech	High	Pump
0xA7A0	Drop too many	Tech	High	Pump

Alarm ID	Alarm message	Category	Alarm priority	Source
0xA7A1	Drop too many	Tech	High	Pump
0xA7A2	Drop too many	Tech	High	Pump
0xA7A3	Drop too many	Tech	High	Pump
0xA7A4	Drop too many	Tech	High	Pump
0xA7A5	Drop too many	Tech	High	Pump
0xA7A6	Drop too many	Tech	High	Pump
0xA7A7	Drop too many	Tech	High	Pump
0xA7A8	Drop too many	Tech	High	Pump
0xA7A9	Drop too many	Tech	High	Pump
0xA7AA	Drop too many	Tech	High	Pump
0xA7AB	Drop too many	Tech	High	Pump
0xA7AC	Drop too many	Tech	High	Pump
0xA7AD	Drop too many	Tech	High	Pump
0xA7AE	Drop too many	Tech	High	Pump
0xA7AF	Drop too many	Tech	High	Pump
0xA7B0	Drop too many	Tech	High	Pump
0xA7B1	Drop too many	Tech	High	Pump
0xA7B2	Drop too many	Tech	High	Pump
0xA7B3	Drop too many	Tech	High	Pump
0xA7B4	Drop too many	Tech	High	Pump
0xA7B5	Drop too many	Tech	High	Pump
0xA7B6	Drop too many	Tech	High	Pump
0xA7DE	Drop alarm	Tech	High	Pump
0xA7DF	Drop alarm	Tech	High	Pump
0xA7E0	Drop alarm	Tech	High	Pump
0xA7E1	Drop alarm	Tech	High	Pump
0xA7E2	Drop alarm	Tech	High	Pump
0xA7E3	Drop alarm	Tech	High	Pump
0xA7E4	Drop alarm	Tech	High	Pump
0xA7E5	Drop alarm	Tech	High	Pump

Alarm ID	Alarm message	Category	Alarm priority	Source
0xA7E6	Drop alarm	Tech	High	Pump
0xA7E7	Drop alarm	Tech	High	Pump
0xA7E8	Drop alarm	Tech	High	Pump
0xA7E9	Drop alarm	Tech	High	Pump
0xA7EA	Drop alarm	Tech	High	Pump
0xA7EB	Drop alarm	Tech	High	Pump
0xA7EC	Drop alarm	Tech	High	Pump
0xA7ED	Drop alarm	Tech	High	Pump
0xA7EE	Drop alarm	Tech	High	Pump
0xA7EF	Drop alarm	Tech	High	Pump
0xA7F0	Drop alarm	Tech	High	Pump
0xA7F1	Drop alarm	Tech	High	Pump
0xA7F2	Drop alarm	Tech	High	Pump
0xA7F3	Drop alarm	Tech	High	Pump
0xA7F4	Drop alarm	Tech	High	Pump
0xA7F5	Drop alarm	Tech	High	Pump
0xA7F6	Syringe disengagement	Tech	High	Pump
0xA7F7	Syringe disengagement	Tech	High	Pump
0xA7F8	Syringe disengagement	Tech	High	Pump
0xA7F9	Syringe disengagement	Tech	High	Pump
0xA7FA	Syringe disengagement	Tech	High	Pump
0xA7FB	Syringe disengagement	Tech	High	Pump
0xA7FC	Syringe disengagement	Tech	High	Pump
0xA7FD	Syringe disengagement	Tech	High	Pump
0xA7FE	Syringe disengagement	Tech	High	Pump
0xA7FF	Syringe disengagement	Tech	High	Pump
0xA800	Syringe disengagement	Tech	High	Pump
0xA801	Syringe disengagement	Tech	High	Pump
0xA802	Syringe disengagement	Tech	High	Pump
0xA803	Syringe disengagement	Tech	High	Pump

Alarm ID	Alarm message	Category	Alarm priority	Source
0xA804	Syringe disengagement	Tech	High	Pump
0xA805	Syringe disengagement	Tech	High	Pump
0xA806	Syringe disengagement	Tech	High	Pump
0xA807	Syringe disengagement	Tech	High	Pump
0xA808	Syringe disengagement	Tech	High	Pump
0xA809	Syringe disengagement	Tech	High	Pump
0xA80A	Syringe disengagement	Tech	High	Pump
0xA80B	Syringe disengagement	Tech	High	Pump
0xA80C	Syringe disengagement	Tech	High	Pump
0xA80D	Syringe disengagement	Tech	High	Pump
0xA80E	Mechanical Abnormal	Tech	High	Pump
0xA80F	Mechanical Abnormal	Tech	High	Pump
0xA810	Mechanical Abnormal	Tech	High	Pump
0xA811	Mechanical Abnormal	Tech	High	Pump
0xA812	Mechanical Abnormal	Tech	High	Pump
0xA813	Mechanical Abnormal	Tech	High	Pump
0xA814	Mechanical Abnormal	Tech	High	Pump
0xA815	Mechanical Abnormal	Tech	High	Pump
0xA816	Mechanical Abnormal	Tech	High	Pump
0xA817	Mechanical Abnormal	Tech	High	Pump
0xA818	Mechanical Abnormal	Tech	High	Pump
0xA819	Mechanical Abnormal	Tech	High	Pump
0xA81A	Mechanical Abnormal	Tech	High	Pump
0xA81B	Mechanical Abnormal	Tech	High	Pump
0xA81C	Mechanical Abnormal	Tech	High	Pump
0xA81D	Mechanical Abnormal	Tech	High	Pump
0xA81E	Mechanical Abnormal	Tech	High	Pump
0xA81F	Mechanical Abnormal	Tech	High	Pump
0xA820	Mechanical Abnormal	Tech	High	Pump
0xA821	Mechanical Abnormal	Tech	High	Pump

Alarm ID	Alarm message	Category	Alarm priority	Source
0xA822	Mechanical Abnormal	Tech	High	Pump
0xA823	Mechanical Abnormal	Tech	High	Pump
0xA824	Mechanical Abnormal	Tech	High	Pump
0xA825	Mechanical Abnormal	Tech	High	Pump
0xA826	Sensor alarm	Tech	High	Pump
0xA827	Sensor alarm	Tech	High	Pump
0xA828	Sensor alarm	Tech	High	Pump
0xA829	Sensor alarm	Tech	High	Pump
0xA82A	Sensor alarm	Tech	High	Pump
0xA82B	Sensor alarm	Tech	High	Pump
0xA82C	Sensor alarm	Tech	High	Pump
0xA82D	Sensor alarm	Tech	High	Pump
0xA82E	Sensor alarm	Tech	High	Pump
0xA82F	Sensor alarm	Tech	High	Pump
0xA830	Sensor alarm	Tech	High	Pump
0xA831	Sensor alarm	Tech	High	Pump
0xA832	Sensor alarm	Tech	High	Pump
0xA833	Sensor alarm	Tech	High	Pump
0xA834	Sensor alarm	Tech	High	Pump
0xA835	Sensor alarm	Tech	High	Pump
0xA836	Sensor alarm	Tech	High	Pump
0xA837	Sensor alarm	Tech	High	Pump
0xA838	Sensor alarm	Tech	High	Pump
0xA839	Sensor alarm	Tech	High	Pump
0xA83A	Sensor alarm	Tech	High	Pump
0xA83B	Sensor alarm	Tech	High	Pump
0xA83C	Sensor alarm	Tech	High	Pump
0xA83D	Sensor alarm	Tech	High	Pump
0xA83E	Door Open	Tech	High	Pump
0xA83F	Door Open	Tech	High	Pump

Alarm ID	Alarm message	Category	Alarm priority	Source
0xA840	Door Open	Tech	High	Pump
0xA841	Door Open	Tech	High	Pump
0xA842	Door Open	Tech	High	Pump
0xA843	Door Open	Tech	High	Pump
0xA844	Door Open	Tech	High	Pump
0xA845	Door Open	Tech	High	Pump
0xA846	Door Open	Tech	High	Pump
0xA847	Door Open	Tech	High	Pump
0xA848	Door Open	Tech	High	Pump
0xA849	Door Open	Tech	High	Pump
0xA84A	Door Open	Tech	High	Pump
0xA84B	Door Open	Tech	High	Pump
0xA84C	Door Open	Tech	High	Pump
0xA84D	Door Open	Tech	High	Pump
0xA84E	Door Open	Tech	High	Pump
0xA84F	Door Open	Tech	High	Pump
0xA850	Door Open	Tech	High	Pump
0xA851	Door Open	Tech	High	Pump
0xA852	Door Open	Tech	High	Pump
0xA853	Door Open	Tech	High	Pump
0xA854	Door Open	Tech	High	Pump
0xA855	Door Open	Tech	High	Pump
0xA856	end of infusion	Tech	High	Pump
0xA857	end of infusion	Tech	High	Pump
0xA858	end of infusion	Tech	High	Pump
0xA859	end of infusion	Tech	High	Pump
0xA85A	end of infusion	Tech	High	Pump
0xA85B	end of infusion	Tech	High	Pump
0xA85C	end of infusion	Tech	High	Pump
0xA85D	end of infusion	Tech	High	Pump

Alarm ID	Alarm message	Category	Alarm priority	Source
0xA85E	end of infusion	Tech	High	Pump
0xA85F	end of infusion	Tech	High	Pump
0xA860	end of infusion	Tech	High	Pump
0xA861	end of infusion	Tech	High	Pump
0xA862	end of infusion	Tech	High	Pump
0xA863	end of infusion	Tech	High	Pump
0xA864	end of infusion	Tech	High	Pump
0xA865	end of infusion	Tech	High	Pump
0xA866	end of infusion	Tech	High	Pump
0xA867	end of infusion	Tech	High	Pump
0xA868	end of infusion	Tech	High	Pump
0xA869	end of infusion	Tech	High	Pump
0xA86A	end of infusion	Tech	High	Pump
0xA86B	end of infusion	Tech	High	Pump
0xA86C	end of infusion	Tech	High	Pump
0xA86D	end of infusion	Tech	High	Pump
0xA86E	Syringe Empty	Tech	High	Pump
0xA86F	Syringe Empty	Tech	High	Pump
0xA870	Syringe Empty	Tech	High	Pump
0xA871	Syringe Empty	Tech	High	Pump
0xA872	Syringe Empty	Tech	High	Pump
0xA873	Syringe Empty	Tech	High	Pump
0xA874	Syringe Empty	Tech	High	Pump
0xA875	Syringe Empty	Tech	High	Pump
0xA876	Syringe Empty	Tech	High	Pump
0xA877	Syringe Empty	Tech	High	Pump
0xA878	Syringe Empty	Tech	High	Pump
0xA879	Syringe Empty	Tech	High	Pump
0xA87A	Syringe Empty	Tech	High	Pump
0xA87B	Syringe Empty	Tech	High	Pump

Alarm ID	Alarm message	Category	Alarm priority	Source
0xA87C	Syringe Empty	Tech	High	Pump
0xA87D	Syringe Empty	Tech	High	Pump
0xA87E	Syringe Empty	Tech	High	Pump
0xA87F	Syringe Empty	Tech	High	Pump
0xA880	Syringe Empty	Tech	High	Pump
0xA881	Syringe Empty	Tech	High	Pump
0xA882	Syringe Empty	Tech	High	Pump
0xA883	Syringe Empty	Tech	High	Pump
0xA884	Syringe Empty	Tech	High	Pump
0xA885	Syringe Empty	Tech	High	Pump
0xA886	Syringe Near Empty	Tech	Low	Pump
0xA887	Syringe Near Empty	Tech	Low	Pump
0xA888	Syringe Near Empty	Tech	Low	Pump
0xA889	Syringe Near Empty	Tech	Low	Pump
0xA88A	Syringe Near Empty	Tech	Low	Pump
0xA88B	Syringe Near Empty	Tech	Low	Pump
0xA88C	Syringe Near Empty	Tech	Low	Pump
0xA88D	Syringe Near Empty	Tech	Low	Pump
0xA88E	Syringe Near Empty	Tech	Low	Pump
0xA88F	Syringe Near Empty	Tech	Low	Pump
0xA890	Syringe Near Empty	Tech	Low	Pump
0xA891	Syringe Near Empty	Tech	Low	Pump
0xA892	Syringe Near Empty	Tech	Low	Pump
0xA893	Syringe Near Empty	Tech	Low	Pump
0xA894	Syringe Near Empty	Tech	Low	Pump
0xA895	Syringe Near Empty	Tech	Low	Pump
0xA896	Syringe Near Empty	Tech	Low	Pump
0xA897	Syringe Near Empty	Tech	Low	Pump
0xA898	Syringe Near Empty	Tech	Low	Pump
0xA899	Syringe Near Empty	Tech	Low	Pump

Alarm ID	Alarm message	Category	Alarm priority	Source
0xA89A	Syringe Near Empty	Tech	Low	Pump
0xA89B	Syringe Near Empty	Tech	Low	Pump
0xA89C	Syringe Near Empty	Tech	Low	Pump
0xA89D	Syringe Near Empty	Tech	Low	Pump
0xA89E	Infusion Near Done	Tech	Low	Pump
0xA89F	Infusion Near Done	Tech	Low	Pump
0xA8A0	Infusion Near Done	Tech	Low	Pump
0xA8A1	Infusion Near Done	Tech	Low	Pump
0xA8A2	Infusion Near Done	Tech	Low	Pump
0xA8A3	Infusion Near Done	Tech	Low	Pump
0xA8A4	Infusion Near Done	Tech	Low	Pump
0xA8A5	Infusion Near Done	Tech	Low	Pump
0xA8A6	Infusion Near Done	Tech	Low	Pump
0xA8A7	Infusion Near Done	Tech	Low	Pump
0xA8A8	Infusion Near Done	Tech	Low	Pump
0xA8A9	Infusion Near Done	Tech	Low	Pump
0xA8AA	Infusion Near Done	Tech	Low	Pump
0xA8AB	Infusion Near Done	Tech	Low	Pump
0xA8AC	Infusion Near Done	Tech	Low	Pump
0xA8AD	Infusion Near Done	Tech	Low	Pump
0xA8AE	Infusion Near Done	Tech	Low	Pump
0xA8AF	Infusion Near Done	Tech	Low	Pump
0xA8B0	Infusion Near Done	Tech	Low	Pump
0xA8B1	Infusion Near Done	Tech	Low	Pump
0xA8B2	Infusion Near Done	Tech	Low	Pump
0xA8B3	Infusion Near Done	Tech	Low	Pump
0xA8B4	Infusion Near Done	Tech	Low	Pump
0xA8B5	Infusion Near Done	Tech	Low	Pump
0xA8B6	System Abnormal	Tech	Medium	Pump
0xA8B7	System Abnormal	Tech	Medium	Pump

Alarm ID	Alarm message	Category	Alarm priority	Source
0xA8B8	System Abnormal	Tech	Medium	Pump
0xA8B9	System Abnormal	Tech	Medium	Pump
0xA8BA	System Abnormal	Tech	Medium	Pump
0xA8BB	System Abnormal	Tech	Medium	Pump
0xA8BC	System Abnormal	Tech	Medium	Pump
0xA8BD	System Abnormal	Tech	Medium	Pump
0xA8BE	System Abnormal	Tech	Medium	Pump
0xA8BF	System Abnormal	Tech	Medium	Pump
0xA8C0	System Abnormal	Tech	Medium	Pump
0xA8C1	System Abnormal	Tech	Medium	Pump
0xA8C2	System Abnormal	Tech	Medium	Pump
0xA8C3	System Abnormal	Tech	Medium	Pump
0xA8C4	System Abnormal	Tech	Medium	Pump
0xA8C5	System Abnormal	Tech	Medium	Pump
0xA8C6	System Abnormal	Tech	Medium	Pump
0xA8C7	System Abnormal	Tech	Medium	Pump
0xA8C8	System Abnormal	Tech	Medium	Pump
0xA8C9	System Abnormal	Tech	Medium	Pump
0xA8CA	System Abnormal	Tech	Medium	Pump
0xA8CB	System Abnormal	Tech	Medium	Pump
0xA8CC	System Abnormal	Tech	Medium	Pump
0xA8CD	System Abnormal	Tech	Medium	Pump
0xA8CE	Low Battery	Tech	High	Pump
0xA8CF	Low Battery	Tech	High	Pump
0xA8D0	Low Battery	Tech	High	Pump
0xA8D1	Low Battery	Tech	High	Pump
0xA8D2	Low Battery	Tech	High	Pump
0xA8D3	Low Battery	Tech	High	Pump
0xA8D4	Low Battery	Tech	High	Pump
0xA8D5	Low Battery	Tech	High	Pump

Alarm ID	Alarm message	Category	Alarm priority	Source
0xA8D6	Low Battery	Tech	High	Pump
0xA8D7	Low Battery	Tech	High	Pump
0xA8D8	Low Battery	Tech	High	Pump
0xA8D9	Low Battery	Tech	High	Pump
0xA8DA	Low Battery	Tech	High	Pump
0xA8DB	Low Battery	Tech	High	Pump
0xA8DC	Low Battery	Tech	High	Pump
0xA8DD	Low Battery	Tech	High	Pump
0xA8DE	Low Battery	Tech	High	Pump
0xA8DF	Low Battery	Tech	High	Pump
0xA8E0	Low Battery	Tech	High	Pump
0xA8E1	Low Battery	Tech	High	Pump
0xA8E2	Low Battery	Tech	High	Pump
0xA8E3	Low Battery	Tech	High	Pump
0xA8E4	Low Battery	Tech	High	Pump
0xA8E5	Low Battery	Tech	High	Pump
0xA971	KVO Done	Tech	High	Pump
0xA972	KVO Done	Tech	High	Pump
0xA973	KVO Done	Tech	High	Pump
0xA974	KVO Done	Tech	High	Pump
0xA975	KVO Done	Tech	High	Pump
0xA976	KVO Done	Tech	High	Pump
0xA977	KVO Done	Tech	High	Pump
0xA978	KVO Done	Tech	High	Pump
0xA979	KVO Done	Tech	High	Pump
0xA97A	KVO Done	Tech	High	Pump
0xA97B	KVO Done	Tech	High	Pump
0xA97C	KVO Done	Tech	High	Pump
0xA97D	KVO Done	Tech	High	Pump
0xA97E	KVO Done	Tech	High	Pump

Alarm ID	Alarm message	Category	Alarm priority	Source
0xA97F	KVO Done	Tech	High	Pump
0xA980	KVO Done	Tech	High	Pump
0xA981	KVO Done	Tech	High	Pump
0xA982	KVO Done	Tech	High	Pump
0xA983	KVO Done	Tech	High	Pump
0xA984	KVO Done	Tech	High	Pump
0xA985	KVO Done	Tech	High	Pump
0xA986	KVO Done	Tech	High	Pump
0xA987	KVO Done	Tech	High	Pump
0xA988	KVO Done	Tech	High	Pump
0xAB4D	Plugger Grippers Error	Tech	High	Pump
0xAB4E	Plugger Grippers Error	Tech	High	Pump
0xAB4F	Plugger Grippers Error	Tech	High	Pump
0xAB50	Plugger Grippers Error	Tech	High	Pump
0xAB51	Plugger Grippers Error	Tech	High	Pump
0xAB52	Plugger Grippers Error	Tech	High	Pump
0xAB53	Plugger Grippers Error	Tech	High	Pump
0xAB54	Plugger Grippers Error	Tech	High	Pump
0xAB55	Plugger Grippers Error	Tech	High	Pump
0xAB56	Plugger Grippers Error	Tech	High	Pump
0xAB57	Plugger Grippers Error	Tech	High	Pump
0xAB58	Plugger Grippers Error	Tech	High	Pump
0xAB59	Plugger Grippers Error	Tech	High	Pump
0xAB5A	Plugger Grippers Error	Tech	High	Pump
0xAB5B	Plugger Grippers Error	Tech	High	Pump
0xAB5C	Plugger Grippers Error	Tech	High	Pump
0xAB5D	Plugger Grippers Error	Tech	High	Pump
0xAB5E	Plugger Grippers Error	Tech	High	Pump
0xAB5F	Plugger Grippers Error	Tech	High	Pump
0xAB60	Plugger Grippers Error	Tech	High	Pump

Alarm ID	Alarm message	Category	Alarm priority	Source
0xAB61	Plugger Grippers Error	Tech	High	Pump
0xAB62	Plugger Grippers Error	Tech	High	Pump
0xAB63	Plugger Grippers Error	Tech	High	Pump
0xAB64	Plugger Grippers Error	Tech	High	Pump
0xAB65	No Syringe	Tech	High	Pump
0xAB66	No Syringe	Tech	High	Pump
0xAB67	No Syringe	Tech	High	Pump
0xAB68	No Syringe	Tech	High	Pump
0xAB69	No Syringe	Tech	High	Pump
0xAB6A	No Syringe	Tech	High	Pump
0xAB6B	No Syringe	Tech	High	Pump
0xAB6C	No Syringe	Tech	High	Pump
0xAB6D	No Syringe	Tech	High	Pump
0xAB6E	No Syringe	Tech	High	Pump
0xAB6F	No Syringe	Tech	High	Pump
0xAB70	No Syringe	Tech	High	Pump
0xAB71	No Syringe	Tech	High	Pump
0xAB72	No Syringe	Tech	High	Pump
0xAB73	No Syringe	Tech	High	Pump
0xAB74	No Syringe	Tech	High	Pump
0xAB75	No Syringe	Tech	High	Pump
0xAB76	No Syringe	Tech	High	Pump
0xAB77	No Syringe	Tech	High	Pump
0xAB78	No Syringe	Tech	High	Pump
0xAB79	No Syringe	Tech	High	Pump
0xAB7A	No Syringe	Tech	High	Pump
0xAB7B	No Syringe	Tech	High	Pump
0xAB7C	No Syringe	Tech	High	Pump
0xAB7D	Extension Line Detached	Tech	Low	Pump
0xAB7E	Extension Line Detached	Tech	Low	Pump

Alarm ID	Alarm message	Category	Alarm priority	Source
0xAB7F	Extension Line Detached	Tech	Low	Pump
0xAB80	Extension Line Detached	Tech	Low	Pump
0xAB81	Extension Line Detached	Tech	Low	Pump
0xAB82	Extension Line Detached	Tech	Low	Pump
0xAB83	Extension Line Detached	Tech	Low	Pump
0xAB84	Extension Line Detached	Tech	Low	Pump
0xAB85	Extension Line Detached	Tech	Low	Pump
0xAB86	Extension Line Detached	Tech	Low	Pump
0xAB87	Extension Line Detached	Tech	Low	Pump
0xAB88	Extension Line Detached	Tech	Low	Pump
0xAB89	Extension Line Detached	Tech	Low	Pump
0xAB8A	Extension Line Detached	Tech	Low	Pump
0xAB8B	Extension Line Detached	Tech	Low	Pump
0xAB8C	Extension Line Detached	Tech	Low	Pump
0xAB8D	Extension Line Detached	Tech	Low	Pump
0xAB8E	Extension Line Detached	Tech	Low	Pump
0xAB8F	Extension Line Detached	Tech	Low	Pump
0xAB90	Extension Line Detached	Tech	Low	Pump
0xAB91	Extension Line Detached	Tech	Low	Pump
0xAB92	Extension Line Detached	Tech	Low	Pump
0xAB93	Extension Line Detached	Tech	Low	Pump
0xAB94	Extension Line Detached	Tech	Low	Pump
0xAB95	Accumulated Air	Tech	High	Pump
0xAB96	Accumulated Air	Tech	High	Pump
0xAB97	Accumulated Air	Tech	High	Pump
0xAB98	Accumulated Air	Tech	High	Pump
0xAB99	Accumulated Air	Tech	High	Pump
0xAB9A	Accumulated Air	Tech	High	Pump
0xAB9B	Accumulated Air	Tech	High	Pump
0xAB9C	Accumulated Air	Tech	High	Pump

Alarm ID	Alarm message	Category	Alarm priority	Source
0xAB9D	Accumulated Air	Tech	High	Pump
0xAB9E	Accumulated Air	Tech	High	Pump
0xAB9F	Accumulated Air	Tech	High	Pump
0xABA0	Accumulated Air	Tech	High	Pump
0xABA1	Accumulated Air	Tech	High	Pump
0xABA2	Accumulated Air	Tech	High	Pump
0xABA3	Accumulated Air	Tech	High	Pump
0xABA4	Accumulated Air	Tech	High	Pump
0xABA5	Accumulated Air	Tech	High	Pump
0xABA6	Accumulated Air	Tech	High	Pump
0xABA7	Accumulated Air	Tech	High	Pump
0xABA8	Accumulated Air	Tech	High	Pump
0xABA9	Accumulated Air	Tech	High	Pump
0xABAA	Accumulated Air	Tech	High	Pump
0xABAB	Accumulated Air	Tech	High	Pump
0xABAC	Accumulated Air	Tech	High	Pump
0xABAD	Air in Line	Tech	High	Pump
0xABAE	Air in Line	Tech	High	Pump
0xABAF	Air in Line	Tech	High	Pump
0xABB0	Air in Line	Tech	High	Pump
0xABB1	Air in Line	Tech	High	Pump
0xABB2	Air in Line	Tech	High	Pump
0xABB3	Air in Line	Tech	High	Pump
0xABB4	Air in Line	Tech	High	Pump
0xABB5	Air in Line	Tech	High	Pump
0xABB6	Air in Line	Tech	High	Pump
0xABB7	Air in Line	Tech	High	Pump
0xABB8	Air in Line	Tech	High	Pump
0xABB9	Air in Line	Tech	High	Pump
0xABBA	Air in Line	Tech	High	Pump

Alarm ID	Alarm message	Category	Alarm priority	Source
0xABBB	Air in Line	Tech	High	Pump
0xABBC	Air in Line	Tech	High	Pump
0xABBD	Air in Line	Tech	High	Pump
0xABBE	Air in Line	Tech	High	Pump
0xABBF	Air in Line	Tech	High	Pump
0xABC0	Air in Line	Tech	High	Pump
0xABC1	Air in Line	Tech	High	Pump
0xABC2	Air in Line	Tech	High	Pump
0xABC3	Air in Line	Tech	High	Pump
0xABC4	Air in Line	Tech	High	Pump
0xABC5	Downstream Occlusion	Tech	High	Pump
0xABC6	Downstream Occlusion	Tech	High	Pump
0xABC7	Downstream Occlusion	Tech	High	Pump
0xABC8	Downstream Occlusion	Tech	High	Pump
0xABC9	Downstream Occlusion	Tech	High	Pump
0xABCA	Downstream Occlusion	Tech	High	Pump
0xABCB	Downstream Occlusion	Tech	High	Pump
0xABCC	Downstream Occlusion	Tech	High	Pump
0xABCD	Downstream Occlusion	Tech	High	Pump
0xABCE	Downstream Occlusion	Tech	High	Pump
0xABCF	Downstream Occlusion	Tech	High	Pump
0xABD0	Downstream Occlusion	Tech	High	Pump
0xABD1	Downstream Occlusion	Tech	High	Pump
0xABD2	Downstream Occlusion	Tech	High	Pump
0xABD3	Downstream Occlusion	Tech	High	Pump
0xABD4	Downstream Occlusion	Tech	High	Pump
0xABD5	Downstream Occlusion	Tech	High	Pump
0xABD6	Downstream Occlusion	Tech	High	Pump
0xABD7	Downstream Occlusion	Tech	High	Pump
0xABD8	Downstream Occlusion	Tech	High	Pump

Alarm ID	Alarm message	Category	Alarm priority	Source
0xABD9	Downstream Occlusion	Tech	High	Pump
0xABDA	Downstream Occlusion	Tech	High	Pump
0xABDB	Downstream Occlusion	Tech	High	Pump
0xABDC	Downstream Occlusion	Tech	High	Pump
0xABDD	Upstream Occlusion	Tech	High	Pump
0xABDE	Upstream Occlusion	Tech	High	Pump
0xABDF	Upstream Occlusion	Tech	High	Pump
0xABE0	Upstream Occlusion	Tech	High	Pump
0xB799	Upstream Occlusion	Tech	High	Pump
0xB79A	Upstream Occlusion	Tech	High	Pump
0xB79B	Upstream Occlusion	Tech	High	Pump
0xB79C	Upstream Occlusion	Tech	High	Pump
0xB79D	Upstream Occlusion	Tech	High	Pump
0xB79E	Upstream Occlusion	Tech	High	Pump
0xB79F	Upstream Occlusion	Tech	High	Pump
0xB7A0	Upstream Occlusion	Tech	High	Pump
0xB7A1	Upstream Occlusion	Tech	High	Pump
0xB7A2	Upstream Occlusion	Tech	High	Pump
0xB7A3	Upstream Occlusion	Tech	High	Pump
0xB7A4	Upstream Occlusion	Tech	High	Pump
0xB7A5	Upstream Occlusion	Tech	High	Pump
0xB7A6	Upstream Occlusion	Tech	High	Pump
0xB7A7	Upstream Occlusion	Tech	High	Pump
0xB7A8	Upstream Occlusion	Tech	High	Pump
0xB7A9	Upstream Occlusion	Tech	High	Pump
0xB7AA	Upstream Occlusion	Tech	High	Pump
0xB7AB	Upstream Occlusion	Tech	High	Pump
0xB7AC	Upstream Occlusion	Tech	High	Pump
0xB7AD	Empty	Tech	High	Pump
0xB7AE	Empty	Tech	High	Pump

Alarm ID	Alarm message	Category	Alarm priority	Source
0xB7AF	Empty	Tech	High	Pump
0xB7B0	Empty	Tech	High	Pump
0xB7B1	Empty	Tech	High	Pump
0xB7B2	Empty	Tech	High	Pump
0xB7B3	Empty	Tech	High	Pump
0xB7B4	Empty	Tech	High	Pump
0xB7B5	Empty	Tech	High	Pump
0xB7B6	Empty	Tech	High	Pump
0xB7B7	Empty	Tech	High	Pump
0xB7B8	Empty	Tech	High	Pump
0xB7B9	Empty	Tech	High	Pump
0xB7BA	Empty	Tech	High	Pump
0xB7BB	Empty	Tech	High	Pump
0xB7BC	Empty	Tech	High	Pump
0xB7BD	Empty	Tech	High	Pump
0xB7BE	Empty	Tech	High	Pump
0xB7BF	Empty	Tech	High	Pump
0xB7C0	Empty	Tech	High	Pump
0xB7C1	Empty	Tech	High	Pump
0xB7C2	Empty	Tech	High	Pump
0xB7C3	Empty	Tech	High	Pump
0xB7C4	Empty	Tech	High	Pump
0xB7C5	Infusion Set Error	Tech	High	Pump
0xB7C6	Infusion Set Error	Tech	High	Pump
0xB7C7	Infusion Set Error	Tech	High	Pump
0xB7C8	Infusion Set Error	Tech	High	Pump
0xB7C9	Infusion Set Error	Tech	High	Pump
0xB7CA	Infusion Set Error	Tech	High	Pump
0xB7CB	Infusion Set Error	Tech	High	Pump
0xB7CC	Infusion Set Error	Tech	High	Pump

Alarm ID	Alarm message	Category	Alarm priority	Source
0xB7CD	Infusion Set Error	Tech	High	Pump
0xB7CE	Infusion Set Error	Tech	High	Pump
0xB7CF	Infusion Set Error	Tech	High	Pump
0xB7D0	Infusion Set Error	Tech	High	Pump
0xB7D1	Infusion Set Error	Tech	High	Pump
0xB7D2	Infusion Set Error	Tech	High	Pump
0xB7D3	Infusion Set Error	Tech	High	Pump
0xB7D4	Infusion Set Error	Tech	High	Pump
0xB7D5	Infusion Set Error	Tech	High	Pump
0xB7D6	Infusion Set Error	Tech	High	Pump
0xB7D7	Infusion Set Error	Tech	High	Pump
0xB7D8	Infusion Set Error	Tech	High	Pump
0xB7D9	Infusion Set Error	Tech	High	Pump
0xB7DA	Infusion Set Error	Tech	High	Pump
0xB7DB	Infusion Set Error	Tech	High	Pump
0xB7DC	Infusion Set Error	Tech	High	Pump
0xB7DD	Empty	Tech	High	Pump
0xB7DE	Empty	Tech	High	Pump
0xB7DF	Empty	Tech	High	Pump
0xB7E0	Empty	Tech	High	Pump
0xB7E1	Empty	Tech	High	Pump
0xB7E2	Empty	Tech	High	Pump
0xB7E3	Empty	Tech	High	Pump
0xB7E4	Empty	Tech	High	Pump
0xB7E5	Empty	Tech	High	Pump
0xB7E6	Empty	Tech	High	Pump
0xB7E7	Empty	Tech	High	Pump
0xB7E8	Empty	Tech	High	Pump
0xB7E9	Empty	Tech	High	Pump
0xB7EA	Empty	Tech	High	Pump

Alarm ID	Alarm message	Category	Alarm priority	Source
0xB7EB	Empty	Tech	High	Pump
0xB7EC	Empty	Tech	High	Pump
0xB7ED	Empty	Tech	High	Pump
0xB7EE	Empty	Tech	High	Pump
0xB7EF	Empty	Tech	High	Pump
0xB7F0	Empty	Tech	High	Pump
0xB7F1	Empty	Tech	High	Pump
0xB7F2	Empty	Tech	High	Pump
0xB7F3	Empty	Tech	High	Pump
0xB7F4	Empty	Tech	High	Pump
0xB7F5	No Infusion Tube	Tech	High	Pump
0xB7F6	No Infusion Tube	Tech	High	Pump
0xB7F7	No Infusion Tube	Tech	High	Pump
0xB7F8	No Infusion Tube	Tech	High	Pump
0xB7F9	No Infusion Tube	Tech	High	Pump
0xB7FA	No Infusion Tube	Tech	High	Pump
0xB7FB	No Infusion Tube	Tech	High	Pump
0xB7FC	No Infusion Tube	Tech	High	Pump
0xB7FD	No Infusion Tube	Tech	High	Pump
0xB7FE	No Infusion Tube	Tech	High	Pump
0xB7FF	No Infusion Tube	Tech	High	Pump
0xB800	No Infusion Tube	Tech	High	Pump
0xB801	No Infusion Tube	Tech	High	Pump
0xB802	No Infusion Tube	Tech	High	Pump
0xB803	No Infusion Tube	Tech	High	Pump
0xB804	No Infusion Tube	Tech	High	Pump
0xB805	No Infusion Tube	Tech	High	Pump
0xB806	No Infusion Tube	Tech	High	Pump
0xB807	No Infusion Tube	Tech	High	Pump
0xB808	No Infusion Tube	Tech	High	Pump

Alarm ID	Alarm message	Category	Alarm priority	Source
0xB809	No Infusion Tube	Tech	High	Pump
0xB80A	No Infusion Tube	Tech	High	Pump
0xB80B	No Infusion Tube	Tech	High	Pump
0xB80C	No Infusion Tube	Tech	High	Pump
0xB80D	Battery Depleted	Tech	High	Pump
0xB80E	Battery Depleted	Tech	High	Pump
0xB80F	Battery Depleted	Tech	High	Pump
0xB810	Battery Depleted	Tech	High	Pump
0xB811	Battery Depleted	Tech	High	Pump
0xB812	Battery Depleted	Tech	High	Pump
0xB813	Battery Depleted	Tech	High	Pump
0xB814	Battery Depleted	Tech	High	Pump
0xB815	Battery Depleted	Tech	High	Pump
0xB816	Battery Depleted	Tech	High	Pump
0xB817	Battery Depleted	Tech	High	Pump
0xB818	Battery Depleted	Tech	High	Pump
0xB819	Battery Depleted	Tech	High	Pump
0xB81A	Battery Depleted	Tech	High	Pump
0xB81B	Battery Depleted	Tech	High	Pump
0xB81C	Battery Depleted	Tech	High	Pump
0xB81D	Battery Depleted	Tech	High	Pump
0xB81E	Battery Depleted	Tech	High	Pump
0xB81F	Battery Depleted	Tech	High	Pump
0xB820	Battery Depleted	Tech	High	Pump
0xB821	Battery Depleted	Tech	High	Pump
0xB822	Battery Depleted	Tech	High	Pump
0xB823	Battery Depleted	Tech	High	Pump
0xB824	Battery Depleted	Tech	High	Pump
0xB825	Battery Depleted	Tech	High	Pump
0xB826	Battery Depleted	Tech	High	Pump

Alarm ID	Alarm message	Category	Alarm priority	Source
0xB827	System Time Error	Tech	Low	Pump
0xB828	System Time Error	Tech	Low	Pump
0xB829	System Time Error	Tech	Low	Pump
0xB82A	System Time Error	Tech	Low	Pump
0xB82B	System Time Error	Tech	Low	Pump
0xB82C	System Time Error	Tech	Low	Pump
0xB82D	System Time Error	Tech	Low	Pump
0xB82E	System Time Error	Tech	Low	Pump
0xB82F	System Time Error	Tech	Low	Pump
0xB830	System Time Error	Tech	Low	Pump
0xB831	System Time Error	Tech	Low	Pump
0xB832	System Time Error	Tech	Low	Pump
0xB833	System Time Error	Tech	Low	Pump
0xB834	System Time Error	Tech	Low	Pump
0xB835	System Time Error	Tech	Low	Pump
0xB836	System Time Error	Tech	Low	Pump
0xB837	System Time Error	Tech	Low	Pump
0xB838	System Time Error	Tech	Low	Pump
0xB839	System Time Error	Tech	Low	Pump
0xB83A	System Time Error	Tech	Low	Pump
0xB83B	System Time Error	Tech	Low	Pump
0xB83C	System Time Error	Tech	Low	Pump
0xB83D	System Time Error	Tech	Low	Pump
0xB83E	System Time Error	Tech	Low	Pump
0xB841	Battery in Use	Tech	Low	Pump
0xB842	Battery in Use	Tech	Low	Pump
0xB843	Battery in Use	Tech	Low	Pump
0xB844	Battery in Use	Tech	Low	Pump
0xB845	Battery in Use	Tech	Low	Pump
0xB846	Battery in Use	Tech	Low	Pump

Alarm ID	Alarm message	Category	Alarm priority	Source
0xB847	Battery in Use	Tech	Low	Pump
0xB848	Battery in Use	Tech	Low	Pump
0xB849	Battery in Use	Tech	Low	Pump
0xB84A	Battery in Use	Tech	Low	Pump
0xB84B	Battery in Use	Tech	Low	Pump
0xB84C	Battery in Use	Tech	Low	Pump
0xB84D	Battery in Use	Tech	Low	Pump
0xB84E	Battery in Use	Tech	Low	Pump
0xB84F	Battery in Use	Tech	Low	Pump
0xB850	Battery in Use	Tech	Low	Pump
0xB851	Battery in Use	Tech	Low	Pump
0xB852	Battery in Use	Tech	Low	Pump
0xB853	Battery in Use	Tech	Low	Pump
0xB854	Battery in Use	Tech	Low	Pump
0xB855	Battery in Use	Tech	Low	Pump
0xB856	Battery in Use	Tech	Low	Pump
0xB857	Battery in Use	Tech	Low	Pump
0xB858	Battery in Use	Tech	Low	Pump
0xB85B	Reminder	Tech	Low	Pump
0xB85C	Reminder	Tech	Low	Pump
0xB85D	Reminder	Tech	Low	Pump
0xB85E	Reminder	Tech	Low	Pump
0xB85F	Reminder	Tech	Low	Pump
0xB860	Reminder	Tech	Low	Pump
0xB861	Reminder	Tech	Low	Pump
0xB862	Reminder	Tech	Low	Pump
0xB863	Reminder	Tech	Low	Pump
0xB864	Reminder	Tech	Low	Pump
0xB865	Reminder	Tech	Low	Pump
0xB866	Reminder	Tech	Low	Pump

Alarm ID	Alarm message	Category	Alarm priority	Source
0xB867	Reminder	Tech	Low	Pump
0xB868	Reminder	Tech	Low	Pump
0xB869	Reminder	Tech	Low	Pump
0xB86A	Reminder	Tech	Low	Pump
0xB86B	Reminder	Tech	Low	Pump
0xB86C	Reminder	Tech	Low	Pump
0xB86D	Reminder	Tech	Low	Pump
0xB86E	Reminder	Tech	Low	Pump
0xB86F	Reminder	Tech	Low	Pump
0xB870	Reminder	Tech	Low	Pump
0xB871	Reminder	Tech	Low	Pump
0xB872	Reminder	Tech	Low	Pump
0xB873	KVO Running	Tech	Low	Pump
0xB874	KVO Running	Tech	Low	Pump
0xB875	KVO Running	Tech	Low	Pump
0xB876	KVO Running	Tech	Low	Pump
0xB877	KVO Running	Tech	Low	Pump
0xB878	KVO Running	Tech	Low	Pump
0xB879	KVO Running	Tech	Low	Pump
0xB87A	KVO Running	Tech	Low	Pump
0xB87B	KVO Running	Tech	Low	Pump
0xB87C	KVO Running	Tech	Low	Pump
0xB87D	KVO Running	Tech	Low	Pump
0xB87E	KVO Running	Tech	Low	Pump
0xB87F	KVO Running	Tech	Low	Pump
0xB880	KVO Running	Tech	Low	Pump
0xB881	KVO Running	Tech	Low	Pump
0xB882	KVO Running	Tech	Low	Pump
0xB883	KVO Running	Tech	Low	Pump
0xB884	KVO Running	Tech	Low	Pump

Alarm ID	Alarm message	Category	Alarm priority	Source
0xB885	KVO Running	Tech	Low	Pump
0xB886	KVO Running	Tech	Low	Pump
0xB887	KVO Running	Tech	Low	Pump
0xB888	KVO Running	Tech	Low	Pump
0xB889	KVO Running	Tech	Low	Pump
0xB88A	KVO Running	Tech	Low	Pump
0xB88B	Relay Invalid	Tech	High	Pump
0xB88C	Relay Invalid	Tech	High	Pump
0xB88D	Relay Invalid	Tech	High	Pump
0xB88E	Relay Invalid	Tech	High	Pump
0xB88F	Relay Invalid	Tech	High	Pump
0xB890	Relay Invalid	Tech	High	Pump
0xB891	Relay Invalid	Tech	High	Pump
0xB892	Relay Invalid	Tech	High	Pump
0xB893	Relay Invalid	Tech	High	Pump
0xB894	Relay Invalid	Tech	High	Pump
0xB895	Relay Invalid	Tech	High	Pump
0xB896	Relay Invalid	Tech	High	Pump
0xB897	Relay Invalid	Tech	High	Pump
0xB898	Relay Invalid	Tech	High	Pump
0xB899	Relay Invalid	Tech	High	Pump
0xB89A	Relay Invalid	Tech	High	Pump
0xB89B	Relay Invalid	Tech	High	Pump
0xB89C	Relay Invalid	Tech	High	Pump
0xB89D	Relay Invalid	Tech	High	Pump
0xB89E	Relay Invalid	Tech	High	Pump
0xB89F	Relay Invalid	Tech	High	Pump
0xB8A0	Relay Invalid	Tech	High	Pump
0xB8A1	Relay Invalid	Tech	High	Pump
0xB8A2	Relay Invalid	Tech	High	Pump

Alarm ID	Alarm message	Category	Alarm priority	Source
0xB8A3	Relay Invalid	Tech	High	Pump
0xB8A4	Relay Invalid	Tech	High	Pump
0xB8A5	Relay Invalid	Tech	High	Pump
0xB8A6	Relay Invalid	Tech	High	Pump
0xB8A7	Relay Invalid	Tech	High	Pump
0xB8A8	Relay Invalid	Tech	High	Pump
0xB8A9	Relay Invalid	Tech	High	Pump
0xB8AA	Relay Invalid	Tech	High	Pump
0xB8AB	Relay Invalid	Tech	High	Pump
0xB8AC	Relay Invalid	Tech	High	Pump
0xB8AD	Relay Invalid	Tech	High	Pump
0xB8AE	Relay Invalid	Tech	High	Pump
0xB8AF	Relay Invalid	Tech	High	Pump
0xB8B0	Relay Invalid	Tech	High	Pump
0xB8B1	Relay Invalid	Tech	High	Pump
0xB8B2	Relay Invalid	Tech	High	Pump
0xB8B3	Relay Invalid	Tech	High	Pump
0xB8B4	Relay Invalid	Tech	High	Pump
0xB8B5	Relay Invalid	Tech	High	Pump
0xB8B6	Relay Invalid	Tech	High	Pump
0xB8B7	Relay Invalid	Tech	High	Pump
0xB8B8	Relay Invalid	Tech	High	Pump
0xB8B9	Relay Invalid	Tech	High	Pump
0xB8BA	Relay Invalid	Tech	High	Pump
0xB8BB	Relay Invalid Soon	Tech	Low	Pump
0xB8BC	Relay Invalid Soon	Tech	Low	Pump
0xB8BD	Relay Invalid Soon	Tech	Low	Pump
0xB8BE	Relay Invalid Soon	Tech	Low	Pump
0xB8BF	Relay Invalid Soon	Tech	Low	Pump
0xB8C0	Relay Invalid Soon	Tech	Low	Pump

Alarm ID	Alarm message	Category	Alarm priority	Source
0xB8C1	Relay Invalid Soon	Tech	Low	Pump
0xB8C2	Relay Invalid Soon	Tech	Low	Pump
0xB8C3	Relay Invalid Soon	Tech	Low	Pump
0xB8C4	Relay Invalid Soon	Tech	Low	Pump
0xB8C5	Relay Invalid Soon	Tech	Low	Pump
0xB8C6	Relay Invalid Soon	Tech	Low	Pump
0xB8C7	Relay Invalid Soon	Tech	Low	Pump
0xB8C8	Relay Invalid Soon	Tech	Low	Pump
0xB8C9	Relay Invalid Soon	Tech	Low	Pump
0xB8CA	Relay Invalid Soon	Tech	Low	Pump
0xB8CB	Relay Invalid Soon	Tech	Low	Pump
0xB8CC	Relay Invalid Soon	Tech	Low	Pump
0xB8CD	Relay Invalid Soon	Tech	Low	Pump
0xB8CE	Relay Invalid Soon	Tech	Low	Pump
0xB8CF	Relay Invalid Soon	Tech	Low	Pump
0xB8D0	Relay Invalid Soon	Tech	Low	Pump
0xB8D1	Relay Invalid Soon	Tech	Low	Pump
0xB8D2	Relay Invalid Soon	Tech	Low	Pump
0xB8D3	Battery Error	Tech	Low	Pump
0xB8D4	Battery Error	Tech	Low	Pump
0xB8D5	Battery Error	Tech	Low	Pump
0xB8D6	Battery Error	Tech	Low	Pump
0xB8D7	Battery Error	Tech	Low	Pump
0xB8D8	Battery Error	Tech	Low	Pump
0xB8D9	Battery Error	Tech	Low	Pump
0xB8DA	Battery Error	Tech	Low	Pump
0xB8DB	Battery Error	Tech	Low	Pump
0xB8DC	Battery Error	Tech	Low	Pump
0xB8DD	Battery Error	Tech	Low	Pump
0xB8DE	Battery Error	Tech	Low	Pump

Alarm ID	Alarm message	Category	Alarm priority	Source
0xB8DF	Battery Error	Tech	Low	Pump
0xB8E0	Battery Error	Tech	Low	Pump
0xB8E1	Battery Error	Tech	Low	Pump
0xB8E2	Battery Error	Tech	Low	Pump
0xB8E3	Battery Error	Tech	Low	Pump
0xB8E4	Battery Error	Tech	Low	Pump
0xB8E5	Battery Error	Tech	Low	Pump
0xB8E6	Battery Error	Tech	Low	Pump
0xB8E7	Battery Error	Tech	Low	Pump
0xB8E8	Battery Error	Tech	Low	Pump
0xB8E9	Battery Error	Tech	Low	Pump
0xB8EA	Battery Error	Tech	Low	Pump
0xB8EB	Battery Error	Tech	Low	Pump
0xB8EC	Battery Error	Tech	Low	Pump
0xB8ED	Low Battery	Tech	High	Pump
0xB8EE	Low Battery	Tech	High	Pump
0xB8EF	System Abnormal	Tech	Medium	Pump
0xB8F0	System Abnormal	Tech	Medium	Pump
0xB944	CMS/eGW Disconnected	Tech	Low	Pump
0xB945	CMS/eGW Disconnected	Tech	Low	Pump
0xB946	Slave Controller Abnormal	Tech	Low	Pump
0xB947	Slave Controller Abnormal	Tech	Low	Pump
0xB94C	IP Address Conflict	Tech	Low	Pump
0xB94D	IP Address Conflict	Tech	Low	Pump
0xB94E	IP Address Conflict	Tech	Low	Pump
0xB94F	IP Address Conflict	Tech	Low	Pump
0xB950	No Drop Sensor	Tech	Low	Pump
0xB951	No Drop Sensor	Tech	Low	Pump
0xB952	No Drop Sensor	Tech	Low	Pump
0xB953	No Drop Sensor	Tech	Low	Pump

Alarm ID	Alarm message	Category	Alarm priority	Source
0xB954	No Drop Sensor	Tech	Low	Pump
0xB955	No Drop Sensor	Tech	Low	Pump
0xB956	No Drop Sensor	Tech	Low	Pump
0xB957	No Drop Sensor	Tech	Low	Pump
0xB958	No Drop Sensor	Tech	Low	Pump
0xB959	No Drop Sensor	Tech	Low	Pump
0xB95A	No Drop Sensor	Tech	Low	Pump
0xB95B	No Drop Sensor	Tech	Low	Pump
0xB95C	No Drop Sensor	Tech	Low	Pump
0xB95D	No Drop Sensor	Tech	Low	Pump
0xB95E	No Drop Sensor	Tech	Low	Pump
0xB95F	No Drop Sensor	Tech	Low	Pump
0xB960	No Drop Sensor	Tech	Low	Pump
0xB961	No Drop Sensor	Tech	Low	Pump
0xB962	No Drop Sensor	Tech	Low	Pump
0xB963	No Drop Sensor	Tech	Low	Pump
0xB964	No Drop Sensor	Tech	Low	Pump
0xB965	No Drop Sensor	Tech	Low	Pump
0xB966	No Drop Sensor	Tech	Low	Pump
0xB967	No Drop Sensor	Tech	Low	Pump
0xB968	PCA Cable Detached	Tech	High	Pump
0xB969	PCA Cable Detached	Tech	High	Pump
0xB96A	PCA Cable Detached	Tech	High	Pump
0xB96B	PCA Cable Detached	Tech	High	Pump
0xB96C	PCA Cable Detached	Tech	High	Pump
0xB96D	PCA Cable Detached	Tech	High	Pump
0xB96E	PCA Cable Detached	Tech	High	Pump
0xB96F	PCA Cable Detached	Tech	High	Pump
0xB970	PCA Cable Detached	Tech	High	Pump
0xB971	PCA Cable Detached	Tech	High	Pump

Alarm ID	Alarm message	Category	Alarm priority	Source
0xB972	PCA Cable Detached	Tech	High	Pump
0xB973	PCA Cable Detached	Tech	High	Pump
0xB974	PCA Cable Detached	Tech	High	Pump
0xB975	PCA Cable Detached	Tech	High	Pump
0xB976	PCA Cable Detached	Tech	High	Pump
0xB977	PCA Cable Detached	Tech	High	Pump
0xB978	PCA Cable Detached	Tech	High	Pump
0xB979	PCA Cable Detached	Tech	High	Pump
0xB97A	PCA Cable Detached	Tech	High	Pump
0xB97B	PCA Cable Detached	Tech	High	Pump
0xB97C	PCA Cable Detached	Tech	High	Pump
0xB97D	PCA Cable Detached	Tech	High	Pump
0xB97E	PCA Cable Detached	Tech	High	Pump
0xB97F	PCA Cable Detached	Tech	High	Pump
0xB980	Infusion Set Disengaged	Tech	High	Pump
0xB981	Infusion Set Disengaged	Tech	High	Pump
0xB982	Infusion Set Disengaged	Tech	High	Pump
0xB983	Infusion Set Disengaged	Tech	High	Pump
0xB984	Infusion Set Disengaged	Tech	High	Pump
0xB985	Infusion Set Disengaged	Tech	High	Pump
0xB986	Infusion Set Disengaged	Tech	High	Pump
0xB987	Infusion Set Disengaged	Tech	High	Pump
0xB988	Infusion Set Disengaged	Tech	High	Pump
0xB989	Infusion Set Disengaged	Tech	High	Pump
0xB98A	Infusion Set Disengaged	Tech	High	Pump
0xB98B	Infusion Set Disengaged	Tech	High	Pump
0xB98C	Infusion Set Disengaged	Tech	High	Pump
0xB98D	Infusion Set Disengaged	Tech	High	Pump
0xB98E	Infusion Set Disengaged	Tech	High	Pump
0xB98F	Infusion Set Disengaged	Tech	High	Pump

Alarm ID	Alarm message	Category	Alarm priority	Source
0xB990	Infusion Set Disengaged	Tech	High	Pump
0xB991	Infusion Set Disengaged	Tech	High	Pump
0xB992	Infusion Set Disengaged	Tech	High	Pump
0xB993	Infusion Set Disengaged	Tech	High	Pump
0xB994	Infusion Set Disengaged	Tech	High	Pump
0xB995	Infusion Set Disengaged	Tech	High	Pump
0xB996	Infusion Set Disengaged	Tech	High	Pump
0xB997	Infusion Set Disengaged	Tech	High	Pump
0xB998	Syringe disengagement	Tech	High	Pump
0xB999	Syringe disengagement	Tech	High	Pump
0xB99A	Syringe disengagement	Tech	High	Pump
0xB99B	Syringe disengagement	Tech	High	Pump
0xB99C	Syringe disengagement	Tech	High	Pump
0xB99D	Syringe disengagement	Tech	High	Pump
0xB99E	Syringe disengagement	Tech	High	Pump
0xB99F	Syringe disengagement	Tech	High	Pump
0xB9A0	Syringe disengagement	Tech	High	Pump
0xB9A1	Syringe disengagement	Tech	High	Pump
0xB9A2	Syringe disengagement	Tech	High	Pump
0xB9A3	Syringe disengagement	Tech	High	Pump
0xB9A4	Syringe disengagement	Tech	High	Pump
0xB9A5	Syringe disengagement	Tech	High	Pump
0xB9A6	Syringe disengagement	Tech	High	Pump
0xB9A7	Syringe disengagement	Tech	High	Pump
0xB9A8	Syringe disengagement	Tech	High	Pump
0xB9A9	Syringe disengagement	Tech	High	Pump
0xB9AA	Syringe disengagement	Tech	High	Pump
0xB9AB	Syringe disengagement	Tech	High	Pump
0xB9AC	Syringe disengagement	Tech	High	Pump
0xB9AD	Syringe disengagement	Tech	High	Pump

Alarm ID	Alarm message	Category	Alarm priority	Source
0xB9AE	Syringe disengagement	Tech	High	Pump
0xB9AF	Syringe disengagement	Tech	High	Pump
0xB9E4	CMS/eGW Disconnected	Tech	Low	Pump
0xB9E5	CMS/eGW Disconnected	Tech	Low	Pump
0xB9E6	CMS/eGW Disconnected	Tech	Low	Pump
0xB9E7	CMS/eGW Disconnected	Tech	Low	Pump
0xB9E8	CMS/eGW Disconnected	Tech	Low	Pump
0xB9E9	CMS/eGW Disconnected	Tech	Low	Pump
0xB9EA	CMS/eGW Disconnected	Tech	Low	Pump
0xB9EB	CMS/eGW Disconnected	Tech	Low	Pump
0xB9EC	CMS/eGW Disconnected	Tech	Low	Pump
0xB9ED	CMS/eGW Disconnected	Tech	Low	Pump
0xB9EE	CMS/eGW Disconnected	Tech	Low	Pump
0xB9EF	CMS/eGW Disconnected	Tech	Low	Pump
0xB9F0	CMS/eGW Disconnected	Tech	Low	Pump
0xB9F1	CMS/eGW Disconnected	Tech	Low	Pump
0xB9F2	CMS/eGW Disconnected	Tech	Low	Pump
0xB9F3	CMS/eGW Disconnected	Tech	Low	Pump
0xB9F4	CMS/eGW Disconnected	Tech	Low	Pump
0xB9F5	CMS/eGW Disconnected	Tech	Low	Pump
0xB9F6	CMS/eGW Disconnected	Tech	Low	Pump
0xB9F7	CMS/eGW Disconnected	Tech	Low	Pump
0xB9F8	CMS/eGW Disconnected	Tech	Low	Pump
0xB9F9	CMS/eGW Disconnected	Tech	Low	Pump
0xB9FA	CMS/eGW Disconnected	Tech	Low	Pump
0xB9FB	CMS/eGW Disconnected	Tech	Low	Pump
0xBA3D	Secondary VTBI Completed	Tech	High	Pump
0xBA3E	Secondary VTBI Completed	Tech	High	Pump
0xBA3F	Secondary VTBI Completed	Tech	High	Pump
0xBA40	Secondary VTBI Completed	Tech	High	Pump

Alarm ID	Alarm message	Category	Alarm priority	Source
0xBA41	Secondary VTBI Completed	Tech	High	Pump
0xBA42	Secondary VTBI Completed	Tech	High	Pump
0xBA43	Secondary VTBI Completed	Tech	High	Pump
0xBA44	Secondary VTBI Completed	Tech	High	Pump
0xBA45	Secondary VTBI Completed	Tech	High	Pump
0xBA46	Secondary VTBI Completed	Tech	High	Pump
0xBA47	Secondary VTBI Completed	Tech	High	Pump
0xBA48	Secondary VTBI Completed	Tech	High	Pump
0xBA49	Secondary VTBI Completed	Tech	High	Pump
0xBA4A	Secondary VTBI Completed	Tech	High	Pump
0xBA4B	Secondary VTBI Completed	Tech	High	Pump
0xBA4C	Secondary VTBI Completed	Tech	High	Pump
0xBA4D	Secondary VTBI Completed	Tech	High	Pump
0xBA4E	Secondary VTBI Completed	Tech	High	Pump
0xBA4F	Secondary VTBI Completed	Tech	High	Pump
0xBA50	Secondary VTBI Completed	Tech	High	Pump
0xBA51	Secondary VTBI Completed	Tech	High	Pump
0xBA52	Secondary VTBI Completed	Tech	High	Pump
0xBA53	Secondary VTBI Completed	Tech	High	Pump
0xBA54	Secondary VTBI Completed	Tech	High	Pump

9.6 Alarm IDs of Other Devices

Alarm ID	Alarm message	Category	Alarm priority	Source
0xA7C3	Electrode check	Tech	Prompt	EEG
0xA7C4	CH1 Impedance	Tech	Prompt	EEG
0xA7C5	CH1 Offset	Tech	Prompt	EEG
0xA7C6	CH1 EMG	Tech	Prompt	EEG
0xA7C7	CH1 50 Hz / 60 Hz	Tech	Prompt	EEG
0xA7C8	CH1 Interferences	Tech	Prompt	EEG

Alarm ID	Alarm message	Category	Alarm priority	Source
0xA7C9	CH1 Sharp Transients	Tech	Prompt	EEG
0xA7CA	CH1 Artifact	Tech	Prompt	EEG
0xA7CB	CH1 Start	Tech	Prompt	EEG
0xA7CC	CH1 Inhomogeneous	Tech	Prompt	EEG
0xA7CD	CH1 Undifferentiated EEG	Tech	Prompt	EEG
0xA7CE	CH2 Impedance	Tech	Prompt	EEG
0xA7CF	CH2 Offset	Tech	Prompt	EEG
0xA7D0	CH2 EMG	Tech	Prompt	EEG
0xA7D1	CH2 50 Hz / 60 Hz	Tech	Prompt	EEG
0xA7D2	CH2 Interferences	Tech	Prompt	EEG
0xA7D3	CH2 Sharp Transients	Tech	Prompt	EEG
0xA7D4	CH2 Artifact	Tech	Prompt	EEG
0xA7D5	CH2 Start	Tech	Prompt	EEG
0xA7D6	CH2 Inhomogeneous	Tech	Prompt	EEG
0xA7D7	CH2 Undifferentiated EEG	Tech	Prompt	EEG
0xA7D8	No patient lead is connected	Tech	Prompt	EEG
0xA7D9	1a electrode bad	Tech	Prompt	EEG
0xA7DA	1b electrode bad	Tech	Prompt	EEG
0xA7DB	Ref electrode bad	Tech	Prompt	EEG
0xA7DC	2a electrode bad	Tech	Prompt	EEG
0xA7DD	2b electrode bad	Tech	Prompt	EEG
0xA962	CH1 High SR	Phys	High	EEG
0xA963	CH1 Low CFI	Phys	High	EEG
0xA964	CH1 High CFI	Phys	High	EEG
0xA965	CH1 Perform Electrode Check	Tech	Low	EEG
0xA966	CH1 Re-preprocess Electrodes	Tech	Low	EEG

Alarm ID	Alarm message	Category	Alarm priority	Source
0xA967	CH1 Check Patient Cable and Leads	Tech	Low	EEG
0xA968	CH2 High SR	Phys	High	EEG
0xA969	CH2 Low CFI	Phys	High	EEG
0xA96A	CH2 High CFI	Phys	High	EEG
0xA96B	CH2 Perform Electrode Check	Tech	Low	EEG
0xA96C	CH2 Re-preprocess Electrodes	Tech	Low	EEG
0xA96D	CH2 Check Patient Cable and Leads	Tech	Low	EEG
0xA8E6	NO Trigger	Tech	High	IABP
0xA8E7	NO Pressure Trigger	Tech	High	IABP
0xA8E8	NO Pressure Trigger Zero Transducer	Tech	High	IABP
0xA8E9	HR Low	Phys	Medium	IABP
0xA8EA	Check Pacer Timing	Tech	High	IABP
0xA8EB	ECG Detected	Tech	Medium	IABP
0xA8EC	Irregular Trigger	Tech	Medium	IABP
0xA8ED	Trigger Interference	Tech	High	IABP
0xA8EE	Rapid gas loss	Tech	High	IABP
0xA8EF	Leak in IAB circuit	Tech	High	IABP
0xA8F0	IAB Disconnected	Tech	High	IABP
0xA8F1	Blood detected	Tech	High	IABP
0xA8F2	Check IAB Catheter	Tech	High	IABP
0xA8F3	High driver pressure	Tech	High	IABP
0xA8F4	Low Vacuum	Tech	High	IABP
0xA8F5	Augmentation Below limit set	Phys	Medium	IABP
0xA8F6	Low helium	Tech	Medium	IABP
0xA8F7	Low Battery	Tech	Medium	IABP
0xA8F8	System Failure	Tech	High	IABP

Alarm ID	Alarm message	Category	Alarm priority	Source
0xA8F9	Electrical Test Failure	Tech	High	IABP
0xA8FA	Autofill Failure	Tech	High	IABP
0xA8FB	Autofill Failure - No helium	Tech	High	IABP
0xA8FC	Safety disk test failure	Tech	High	IABP
0xA8FD	No patient status available	Tech	High	IABP
0xA8FE	Autofill Required	Tech	High	IABP
0xA8FF	Low Battery(EXT)	Tech	Medium	IABP
0xA900	Maintenance required	Tech	Medium	IABP
0xA901	Prolonged Time in Standby	Tech	Medium	IABP
0xA902	Poor Signal Persist	Tech	High	IABP
0xA903	Irregular pressure trigger	Tech	Medium	IABP
0xA904	No pressure source available	Tech	Medium	IABP
0xA905	Poor Signal Quality	Tech	Medium	IABP
0xA906	Unable to update timing	Tech	Medium	IABP
0xA907	Sensor IAB Failure	Tech	Medium	IABP
0xA908	Sensor IAB Module Failure	Tech	Medium	IABP
0xA909	Unable to Calibrate Sensor IAB	Tech	Medium	IABP
0xA90A	Sensor IAB Calibration Expired	Tech	Medium	IABP
0xA7B7	pArt-S Low	Phys	High	CCO
0xA7B8	pArt-S High	Phys	High	CCO
0xA7B9	pArt-M Low	Phys	High	CCO
0xA7BA	pArt-M High	Phys	High	CCO
0xA7BB	CCO Low	Phys	High	CCO

Alarm ID	Alarm message	Category	Alarm priority	Source
0xA7BC	CCO High	Phys	High	CCO
0xA7BD	CCI Low	Phys	High	CCO
0xA7BE	CCI High	Phys	High	CCO
0xA7BF	ScvO2 Low	Phys	High	CCO
0xA7C0	ScvO2 High	Phys	High	CCO
0xA7C1	Map Drop-check catheter	Tech	High	CCO
0xA7C2	AP/HR Not Available-please check	Tech	High	CCO
0xAB37	RSO2 Reach Critical	Tech	Low	Monitor
0xAB38	Pod Comm. Lost	Tech	High	Monitor
0xAB39	SPO2-2 High	Phys	High	Monitor
0xAB3A	SPO2-2 Low	Phys	High	Monitor
0xAB3B	SPO2-3 High	Phys	High	Monitor
0xAB3C	SPO2-3 Low	Phys	High	Monitor
0xAB3D	SPO2-4 High	Phys	High	Monitor
0xAB3E	SPO2-4 Low	Phys	High	Monitor
0xAB3F	SPO2-5 High	Phys	High	Monitor
0xAB40	SPO2-5 Low	Phys	High	Monitor
0xAB41	SPO2-6 High	Phys	High	Monitor
0xAB42	SPO2-6 Low	Phys	High	Monitor
0xAB43	PR-2 High	Phys	High	Monitor
0xAB44	PR -2 Low	Phys	High	Monitor
0xAB45	PR -3 High	Phys	High	Monitor
0xAB46	PR -3 Low	Phys	High	Monitor
0xAB47	PR -4 High	Phys	High	Monitor
0xAB48	PR -4 Low	Phys	High	Monitor
0xAB49	PR -5 High	Phys	High	Monitor
0xAB4A	PR -5 Low	Phys	High	Monitor
0xAB4B	PR -6 High	Phys	High	Monitor

Alarm ID	Alarm message	Category	Alarm priority	Source
0xAB4C	PR -6 Low	Phys	High	Monitor
0xA9B7	SPO2 High	Phys	High	Monitor
0xA9B8	SPO2 Low	Phys	High	Monitor
0xA9B9	PR High	Phys	High	Monitor
0xA9BA	PR Low	Phys	High	Monitor
0xAA26	RSO2-1 Low	Phys	High	Monitor
0xAA27	RSO2-1 High	Phys	High	Monitor
0xAA28	RSO2-2 Low	Phys	High	Monitor
0xAA29	RSO2-2 High	Phys	High	Monitor
0xAA2A	RSO2-1' Low	Phys	High	Monitor
0xAA2B	RSO2-1' High	Phys	High	Monitor
0xAA2C	RSO2-2' Low	Phys	High	Monitor
0xAA2D	RSO2-2' High	Phys	High	Monitor
0xAA22	Low Perfusion	Tech	Low	Monitor
0xA9DF	Sensor Error	Tech	High	Monitor
0xA9A6	Poor Signal Quality	Tech	High	Monitor
0xBA35	High Technical Alarm	Tech	High	IABP
0xBA36	Medium Technical Alarm	Tech	Medium	IABP
0xBA37	Gas Gain In IAB Circuit	Tech	High	IABP
0xBA38	ECG Lead Off	Tech	Medium	IABP
0xBA39	PPG Poor Signal Quality	Tech	Prompt	Monitor
0xBA3A	GSR Poor Signal Quality	Tech	Prompt	Monitor
0xBA3B	Movement detected	Tech	Medium	Monitor
0xBA3C	Trendelenburg detected	Tech	Low	Monitor
0xAA4D	Check Probe	Tech	High	Monitor
0xA99C	Sensor Calibrating	Tech	Prompt	Monitor
0xAA5A	Low Battery	Tech	High	Monitor

Alarm ID	Alarm message	Category	Alarm priority	Source
0xAA4E	Connect Probe	Tech	Prompt	Monitor
0xB8F2	High Technical Alarm	Tech	High	Hemodialysis
0xB8F3	Medium Technical Alarm	Tech	Medium	Hemodialysis
0xB8F4	Low Technical Alarm	Tech	Low	Hemodialysis
0xB8F5	Air in Blood	Tech	High	Hemodialysis
0xB8F6	Return Disconnection	Tech	High	Hemodialysis
0xB8F7	Return Pressure Dropping	Tech	High	Hemodialysis
0xB8F8	Set Disconnection	Tech	High	Hemodialysis
0xB8F9	Filter Clotted	Tech	High	Hemodialysis
0xB8FA	Plasmafilter Clotted	Tech	High	Hemodialysis
0xB8FB	HP Cartridge Clotted	Tech	High	Hemodialysis
0xB8FC	Blood Leak Detected	Tech	High	Hemodialysis
0xB8FD	Return Extremely Positive	Tech	High	Hemodialysis
0xB8FE	Return Extremely Positive No Recovery	Tech	High	Hemodialysis
0xB8FF	Access Extremely Negative	Tech	High	Hemodialysis
0xB900	Access Extremely Negative No Recovery	Tech	High	Hemodialysis
0xB901	Access Extremely Positive	Tech	High	Hemodialysis
0xB902	Filter Extremely Positive	Tech	High	Hemodialysis
0xB903	Power Failure	Tech	High	Hemodialysis
0xB904	Low Battery	Tech	High	Hemodialysis
0xB905	Unsuitable Ca Solution	Tech	High	Hemodialysis
0xB906	Effluent line not in BLD	Tech	High	Hemodialysis

Alarm ID	Alarm message	Category	Alarm priority	Source
0xB907	Fluid Leak Detected	Tech	High	Hemodialysis
0xB908	Syringe Plunger Not Secured	Tech	High	Hemodialysis
0xB909	Lines Not Clamped	Tech	High	Hemodialysis
0xB90A	Clamp Stuck Closed	Tech	High	Hemodialysis
0xB90B	Blood Pump Rate Wrong	Tech	High	Hemodialysis
0xB90C	Effluent Pump Rate Wrong	Tech	High	Hemodialysis
0xB90D	Replacement Pump Rate Wrong	Tech	High	Hemodialysis
0xB90E	Dialysate Pump Rate Wrong	Tech	High	Hemodialysis
0xB90F	PBP Pump Rate Wrong	Tech	High	Hemodialysis
0xB910	Flow Problem	Tech	Medium	Hemodialysis
0xB911	TMP Excessive	Tech	Medium	Hemodialysis
0xB912	TMPa Excessive	Tech	Medium	Hemodialysis
0xB913	Patient Fluid Gain Excessive	Tech	Medium	Hemodialysis
0xBA17	O2 Sens Err	Tech	Medium	Incubater
0xBA18	Speaker Fail	Tech	Low	Incubater
0xBA1B	Water Low	Tech	Low	Incubater
0xBA1D	Air Htr Inop	Tech	High	Incubater
0xBA1E	Check Hood	Tech	Low	Incubater
0xBA1F	Check Wean	Tech	Low	Incubater
0xBA20	Mat Htr Inop	Tech	Medium	Incubater
0xBA21	Sens Mod Err	Tech	Medium	Incubater
0xBA22	Weaning Fail	Tech	Medium	Incubater
0xBA23	Weaning Done	Tech	Low	Incubater
0xBA24	Int.Tmp.High	Tech	Medium	Incubater
0xBA25	Fan Err	Tech	Medium	Incubater

Alarm ID	Alarm message	Category	Alarm priority	Source
0xBA27	System Fault	Tech	High	Incubater
0xBA29	Hum Inop	Tech	Medium	Incubater
0xBA2D	Ctemp Err	Tech	Medium	Incubater
0xBA30	Ptemp Err	Tech	Medium	Incubater
0xBA31	Amb Temp Err	Tech	Medium	Incubater
0xBA32	No Oxygen	Tech	Low	Incubater
0xBA33	O2 Mod Inop	Tech	Medium	Incubater
0xBA16	T Air High	Phys	Medium	Incubater
0xBA19	T Air Low	Phys	Medium	Incubater
0xBA1A	O2 Low	Phys	Medium	Incubater
0xBA1C	O2 High	Phys	Medium	Incubater
0xBA26	Δ T Skin High	Phys	Medium	Incubater
0xBA28	Δ T Skin Low	Phys	Medium	Incubater
0xBA2A	Humidity Low	Phys	Low	Incubater
0xBA2B	T Centr Low	Phys	Medium	Incubater
0xBA2C	T Centr High	Phys	Medium	Incubater
0xBA2E	T Peri Low	Phys	Medium	Incubater
0xBA2F	T Peri High	Phys	Medium	Incubater
0xBA34	T Matt High	Phys	Medium	Incubater
0xA6D6	No Cable Connected	Tech	High	SpO2
0xA6D7	Cable Life Expired	Tech	Low	SpO2
0xA6D8	Incompatible Cable	Tech	Medium	SpO2
0xA6D9	Unrecognized Cable	Tech	Medium	SpO2
0xA6DA	Defective Cable	Tech	Medium	SpO2
0xA6DB	Cable Life Near Expiration	Tech	Low	SpO2
0xA6DC	No Sensor Connected	Tech	High	SpO2
0xA6DD	Sensor Life Expired	Tech	Low	SpO2
0xA6DE	Incompatible Sensor	Tech	Medium	SpO2

Alarm ID	Alarm message	Category	Alarm priority	Source
0xA6DF	Unrecognized Sensor	Tech	Medium	SpO2
0xA6E0	Defective Sensor	Tech	Medium	SpO2
0xA6E1	Emitter Temp Out of Range	Tech	Low	SpO2
0xA6E2	Sensor Current Limit Exceeded	Tech	Low	SpO2
0xA6E3	Sensor Life Near Expiration	Tech	Low	SpO2
0xA6E4	No Tape	Tech	High	SpO2
0xA6E5	Tape Life Expired	Tech	Low	SpO2
0xA6E6	Incompatible Tape	Tech	Medium	SpO2
0xA6E7	Unrecognized Tape	Tech	Medium	SpO2
0xA6E8	Defective Tape	Tech	Medium	SpO2
0xA6E9	Sensor Calibrating	Tech	Prompt	SpO2
0xA6EA	Sensor Off Patient	Tech	High	SpO2
0xA6EB	Pulse Search	Tech	Prompt	SpO2
0xA6EC	Interference Detected	Tech	Prompt	SpO2
0xA6ED	Low Perfusion Index	Tech	Prompt	SpO2
0xA6EE	Demo Mode	Tech	Prompt	SpO2
0xA6EF	Tape Life Near Expiration	Tech	Low	SpO2
0xA6F0	Long Calibration	Tech	Prompt	SpO2
0xA6F1	Check Sensor Connection	Tech	Prompt	SpO2
0xA6F2	SpO2 Only Mode	Tech	Prompt	SpO2
0xA6F3	No Cable Connected	Tech	High	SpO2
0xA6F4	Incompatible Cable	Tech	Medium	SpO2
0xA6F5	Unrecognized Cable	Tech	Medium	SpO2
0xA6F6	Defective Cable	Tech	Medium	SpO2
0xA6F7	No Sensor Connected	Tech	High	SpO2

Alarm ID	Alarm message	Category	Alarm priority	Source
0xA6F8	Incompatible Sensor	Tech	Medium	SpO2
0xA6F9	Unrecognized Sensor	Tech	Medium	SpO2
0xA6FA	Defective Sensor	Tech	Medium	SpO2
0xA6FB	Sensor Off Patient	Tech	High	SpO2
0xA6FC	Patient Interference Detected	Tech	Prompt	SpO2
0xA6FD	Background Interference Detected	Tech	Prompt	SpO2
0xA6FE	No Tape	Tech	High	SpO2
0xA6FF	Incompatible Tape	Tech	Medium	SpO2
0xA700	Defective Tape	Tech	Medium	SpO2
0xA701	Cable Life Expired	Tech	Low	SpO2
0xA702	Sensor Life Expired	Tech	Low	SpO2
0xA703	Tape Life Expired	Tech	Low	SpO2
0xA704	Cable Life Near Expiration	Tech	Low	SpO2
0xA705	Sensor Life Near Expiration	Tech	Low	SpO2
0xA706	Tape Life Near Expiration	Tech	Low	SpO2
0xA707	Sensor initializing	Tech	Prompt	SpO2
0xA708	Check Sensor Connection	Tech	Prompt	SpO2
0xA709	Low Signal IQ	Tech	Prompt	SpO2
0xA70A	Low PR Confidence	Tech	Prompt	SpO2
0xA70B	Low PI Confidence	Tech	Prompt	SpO2
0xA70C	Low SpCO Confidence	Tech	Prompt	SpO2
0xA70D	Low SpCO Perfusion Index	Tech	Prompt	SpO2
0xA70E	Low SpMet Confidence	Tech	Prompt	SpO2

Alarm ID	Alarm message	Category	Alarm priority	Source
0xA70F	Low SpMet Perfusion Index	Tech	Prompt	SpO2
0xA710	Low SpHb Confidence	Tech	Prompt	SpO2
0xA711	Low SpHb Perfusion Index	Tech	Prompt	SpO2
0xA712	Low Desat Index Confidence	Tech	Prompt	SpO2
0xA713	Low PI Delta Confidence	Tech	Prompt	SpO2
0xA714	Low SpOC Confidence	Tech	Prompt	SpO2
0xA715	Low SpOC Perfusion Index	Tech	Prompt	SpO2
0xA716	Low PVI Confidence	Tech	Prompt	SpO2
0xA717	Low RR Confidence	Tech	Prompt	SpO2
0xA718	Low RR Signal Strength	Tech	Prompt	SpO2
0xA719	Bad Sensor Placement	Tech	Prompt	SpO2
0xA71A	Respiratory Pause	Phys	High	SpO2
0xA71B	Low RR Confidence	Tech	Prompt	SpO2
0xA71C	Low RR Signal Strength	Tech	Prompt	SpO2
0xA71D	Bad Sensor Placement	Tech	Prompt	SpO2
0xA71E	Respiratory Pause	Phys	High	SpO2
0xA71F	Low Confidence	Phys	Prompt	SpO2
0xA720	Low Perfusion Index	Phys	Prompt	SpO2
0xA721	SpO2 High	Phys	High	SpO2
0xA722	SpO2 Low	Phys	High	SpO2
0xA723	PR High	Phys	High	SpO2
0xA724	PR Low	Phys	High	SpO2
0xA725	PI High	Phys	Medium	SpO2

Alarm ID	Alarm message	Category	Alarm priority	Source
0xA726	PI Low	Phys	Medium	SpO2
0xA727	SpCO High	Phys	High	SpO2
0xA728	SpCO Low	Phys	High	SpO2
0xA729	SpMET High	Phys	High	SpO2
0xA72A	SpMET Low	Phys	High	SpO2
0xA72B	SpHb High	Phys	High	SpO2
0xA72C	SpHb Low	Phys	High	SpO2
0xA72D	Desat Index	Phys	Medium	SpO2
0xA72E	Desat Index	Phys	Medium	SpO2
0xA72F	PI Delta High	Phys	Medium	SpO2
0xA730	PI Delta low	Phys	Medium	SpO2
0xA731	SpOC High	Phys	High	SpO2
0xA732	SpOC Low	Phys	High	SpO2
0xA733	PVI High	Phys	Medium	SpO2
0xA734	PVI Low	Phys	Medium	SpO2
0xA735	RR High	Phys	High	SpO2
0xA736	RR Low	Phys	High	SpO2
0xA737	RR High	Phys	High	SpO2
0xA738	RR Low	Phys	High	SpO2
0xA739	ORI High	Phys	High	SpO2
0xA73A	ORI Low	Phys	High	SpO2
0xA73B	Spot Check	Tech	Prompt	SpO2
0xA73C	Alarm Silence	Tech	Prompt	SpO2
0xA73D	Alarm All Mute	Tech	Prompt	SpO2
0xA73E	Low Battery	Tech	High	SpO2
0xBA86	High Filter Pressure	Tech	High	Hemodialysis
0xBA87	Change Set	Tech	High	Hemodialysis
0xBA88	Access Extremely Positive	Tech	High	Hemodialysis

Alarm ID	Alarm message	Category	Alarm priority	Source
0xBA89	Return Extremely Negative	Tech	High	Hemodialysis
0xBA8A	Membrane Pressure Excessive	Tech	Medium	Hemodialysis
0xBA8B	Blood Flow Stopped	Tech	Low	Hemodialysis
0xBA8C	Membrane Pressure Rising	Tech	Low	Hemodialysis
0xBA8D	Return Extremely Positive	Tech	High	Hemodialysis
0xBA8E	Flow Problem	Tech	Low	Hemodialysis
0xBA8F	Information Alarm	Tech	Prompt	Hemodialysis

10 Capturing Fault Data

The BeneLink module has a built-in data capture plug-in. If the external device connected to the monitor via the BeneLink module has a failure, protocol data when the failure happened can be captured for analysis and troubleshooting.

10.1 Tools Required for Data Capture

The following tools are required for data capture:

- ID adapter (ID: 5000B000)
- USB-to-serial cable
- Personal computer (PC)
- DeviceSimulator program (V2.3.0 or above) running on the PC
- Network cable

10.2 Data Capture Principle

The external device communicates with the BeneLink module via the network connector on the BeneLink module. Communication data is output to a PC where the DeviceSimulator program runs. Then the data is analyzed on the PC to look for the cause of failure and to help troubleshooting. The following picture shows the principle of data capture:

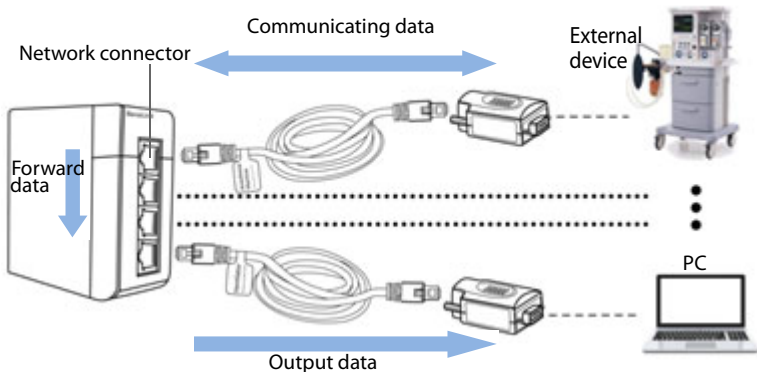

10.3 Performing Data Capture

To capture data when the failure occurred, follow this procedure:

1. Connect the ID adapter (ID: 500B000) to the network connector of the BeneLink module via a network cable. For example, if the failed external device is connected to network connector 1, connect the data capture ID adapter to connector 2, or 3, or 4.
2. Connect the ID adapter to the PC via a USB-to-serial cable.
3. Run the DeviceSimulator program on the PC. Configure the program as follows:
 - ◆ **Serial Port:** select the COM where the USB-to-serial cable is connected.
 - ◆ **Machine:** select Capture Device Raw Data.
4. Select **Run** to start capturing data. Then a file named DeviceSimulatorCOM(X)xxxx-xx-xx-xx-xx-xx.txt is saved under the directory where the DeviceSimulator is located. The meaning of the file name is as follows:
 - ◆ X refers to the label of COM.
 - ◆ xxxx-xx-xx-xx-xx-xx refers to the time (year-month-day-hour-minute-second) when data is captured.

